

WESO

WERKZEUGBAU



Abkantwerkzeuge
Press Brake Tools



Westermann *24*
Abkantwerkzeuge · Schleiftechnik

Westermann24 wird
WESO Werkzeugbau

WESO 
WERKZEUGBAU

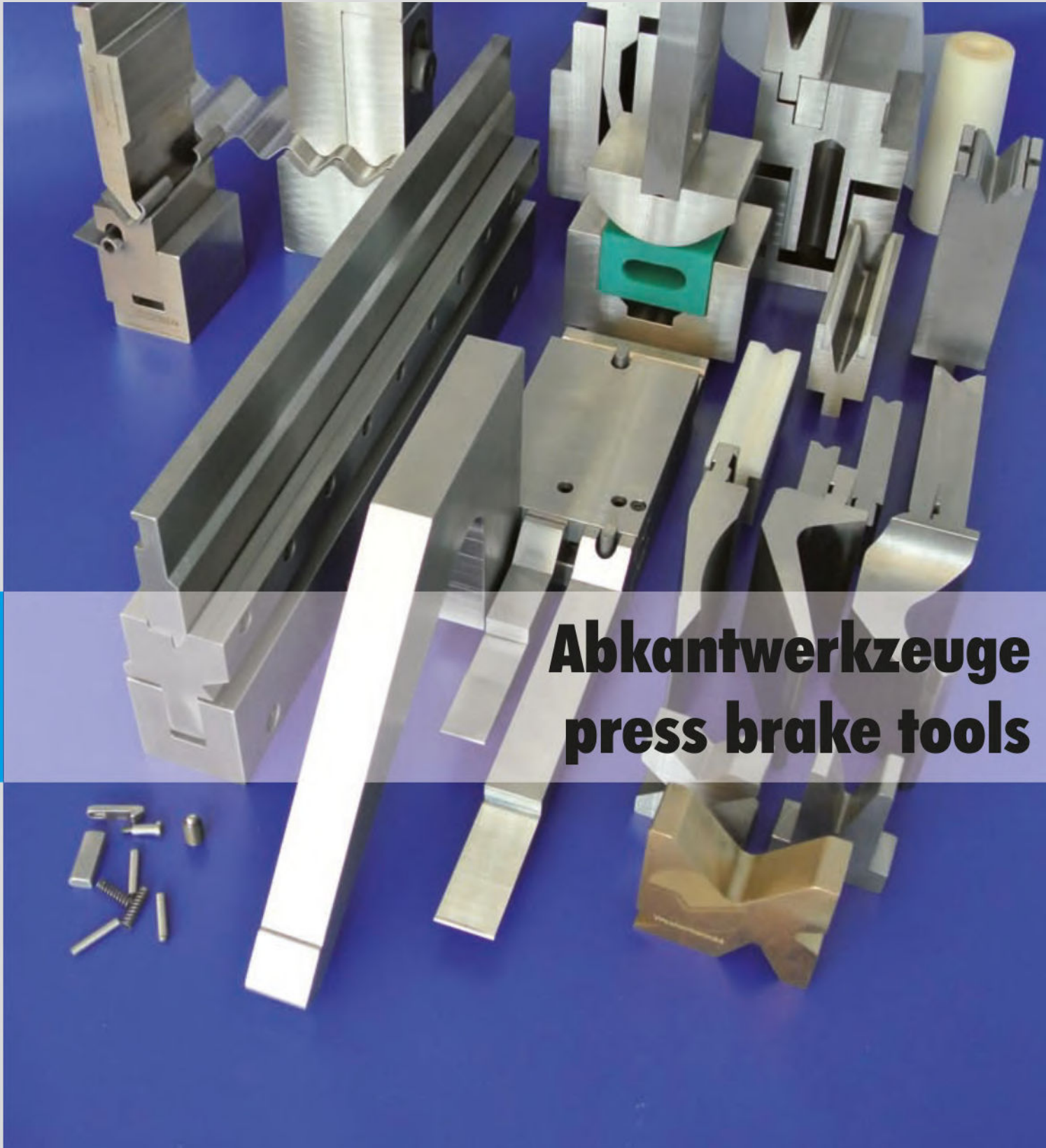

**Abkantwerkzeuge
press brake tools**



Abkantwerkzeuge von Westermann - Tradition, die verbindet.

Westermann24 kann auf eine 100 jährige Tradition zurückblicken. Als Hersteller von Abkantwerkzeugen sehen Sie in uns einen direkten Partner für Ihre Werkzeugversorgung.

Unser Mitarbeiterteam steht Ihnen mit Begeisterung, Qualifikation und persönlichem Einsatz zur Verfügung, um Ihre Erwartungen zu erfüllen. Denn im Zentrum unseres Denkens und Handelns stehen ganz klar Sie, lieber Kunde und die Mehrwerte, die wir Ihnen bieten können.

Das ständige Streben nach optimaler Werkzeugversorgung liegt uns sehr am Herzen, und wir sind dankbar, dass viele von Ihnen diesen Weg mit uns gemeinsam gehen. Auch das verbindet uns.

Wir freuen uns auf den gemeinsamen Weg mit Ihnen in die Zukunft.

Press brake tools by Westermann - Tradition which connects

Westermann24 can look back on 100 years of tradition.

We see ourselves as developer and producer of press brake tools, as a premium partner of your tool supply.

Our interdisciplinary team of staff is ready to fulfil your expectations with qualification, enthusiasm and personal endeavor.

You and your genuine added values from us are in the center of our attention and action.

Constant striving for optimizing the supply of tools is very close to our hearts, and we are thankful because many of you walk this way together with us.

That connects too.

We are very glad to walk this way together in the future.

Inhalt / Content

Line	Inhalt / Content	für Abkantpressen / for Press brake type	Seite / Page
Orange Line	Oberwerkzeuge / Upper Tools	Amada, Atlantic, Adira, Bystronic-Beyeler Euro-B, CR-Electronic, Durmazlar, Ermaksan, Gasparini, Guifil, Haco, Imal, Mecos, Megobal, Promecam, SMD...	5
	Unterwerkzeuge / Lower Tools		27
Green Line	Oberwerkzeuge / Upper Tools	Trumpf, Bystronic - Hämmerle, LVD, oder für Abkantpressen mit Klemmsystem NSCL (New Standard Clamping)	49
	Unterwerkzeuge / Lower Tools	Trumpf, Bystronic-Hämmerle oder mit Tischnut für Zapfen 13x20mm	63
Yellow Line	Oberwerkzeuge / Upper Tools	Bystronic-Beyeler: Euro A-Safan, R, RF, S, SE, RF-A	73
	Unterwerkzeuge / Lower Tools	Bystronic-Beyeler, Bystronic-Hämmerle, Safan, SMD, Trumpf, oder mit Tischnut für Zapfen 13 x 20 mm	93
Red Line	Oberwerkzeuge / Upper Tools L	LVD	101
	Unterwerkzeuge / Lower Tools L		112
	Oberwerkzeuge / Upper Tools E	EHT	117
	Unterwerkzeuge / Lower Tools E		126
	Oberwerkzeuge / Upper Tools W	Weinbrenner	132
	Unterwerkzeuge / Lower Tools W		146
	Oberwerkzeuge / Upper Tools H	Haco	152
Blue Line	Sonderwerkzeuge / Special tools		159
	Abdruckfreies Kanten / Mark free bending		177
Black Line	Adapter / Adapters		181
	Matrizen mit Einlaufwellen / Roller dies		194
	Schwenkbiegewerkzeuge / Folding tools		196
	Blockmatrizen / Block dies		207
	Verstellbare Matrizen / Adjustable dies		211
	Flexo		219
	VARIO		223
Silver Line	Dienstleistungen / Services		225

Oberwerkzeuge / Upper tools

direkt einsetzbar auf Abkantpressen von / directly able to work on bending presses of:

Amada, Atlantic, Adira, Bystronic-Beyeler Euro-B, CR-Electronic, Durmazlar, Ermaksan, Gasparini, Guifil, Haco, Imal, Mecos, Megobal, Promecam, SMD...



Orange Line

direkt einsetzbar auf Abkantpressen von:
Amada, Atlantic, Adira, Bystronic-Beyeler Euro-B,
CR-Electronic, Durmazlar, Ermaksan, Gasparini,
Guifil, Haco, Imal, Mecos, Megobal, Promecam,
SMD, u.v.m.

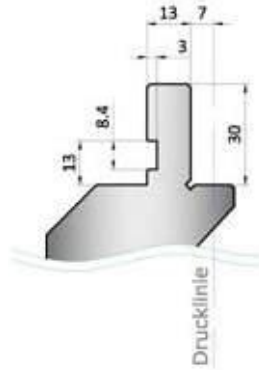

directly able to work on bending presses of:
Amada, Atlantic, Adira, Bystronic-Beyeler Euro-B,
CR-Electronic, Durmazlar, Ermaksan, Gasparini,
Guifil, Haco, Imal, Mecos, Megobal, Promecam,
SMD, and others

Material:

Westermann24 nutzt die vielfältigen Möglichkeiten der Werkstoffkunde, um Ihnen bestmögliche Qualität zu garantieren.

Verwendete Werkstoffe sind:

- I: C45
- II: C45, vergütet auf 800-850N/mm²
- III: 42CrMo4, vergütet auf 950-1050N/mm²
- Werkzeuge auf Anfrage: 1.2312, vergütet auf 1000-1200N/mm²

Ausführung:

Alle Biegeradien sind geschliffen und gehärtet

Werkzeuglängen:

Die Werkzeuglängen sind bei den Artikelnummern angegeben.
Artikelnummern ohne Längenangabe sind auf Anfrage.

sektionierte Werkzeugsätze:

Oberwerkzeuge:

OW 835mm sektioniert in: 10,15,20,40,50,200,300,100 Horn links, 100 Horn rechts

Unterwerkzeuge:

UW 835mm sektioniert in: 10,15,20,40,50,100,200,400

Belastbarkeit:

Die Belastbarkeit der Werkzeuge ist bei den Artikelnummern angegeben.
Werkzeuge die höher belastet werden sollen, können auf Anfrage konstruiert werden.
(siehe Seite 161)

material:

Westermann24 uses the many possibilities of the material engineering, to guarantee best quality.

used materials are:

- I: C45
- II: C45, tempered to 800-850N/mm²
- III: 42CrMo4, tempered to 950-1050N/mm²
- tools on request: 1.2312, tempered to 1000-1200N/mm²

design:

All radii are grinded and hardened

length of the tool:

The tool length are posted with the art-no.
Article- number without length- determination are available on request.

tool sets divided into sections:

Upper tool:

OW 835mm sectioned in: 10,15,20,40,50,200,300,100 horn left, 100 horn right

lower tool:

UW 835mm sectioned in: 10,15,20,40,50,100,200,400

loading capacity:

The loading capacity of the tools is specified by the article number.
Tools which will also be loaded more heavily, can be designed by agreement with the relevant application engineering. (see Page 161)



70.501 Modifikation : Bystronic-Beyeler Euro

70.501 modification : Bystronic-Beyeler Euro

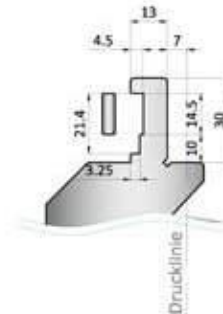

70.948 Modifikation : Nut mit Stahlleiste für sektionierte Werkzeuge

70.948 modification : Groove with steel strip for sectioned tools

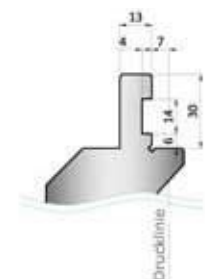

70.503 Modifikation : Bystronic-Beyeler Euro , Safan

70.503 modification : Bystronic-Beyeler Euro , Safan

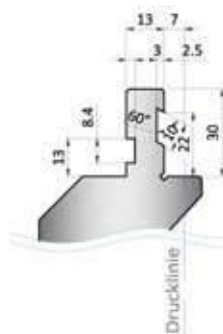

70.1050 Modifikation : Nut für pneumatische Klemmung „Clark“

70.1050 modification : Groove with pneumatic clamping „Clark“



70.600 Modifikation : hydraulische Klemmung Gasparini

70.600 modification : hydraulic clamping Gasparini

415 mm

835 mm

835 mm

	α	R	H	T/mt	Mt
11.100	90°	0.80	66.60	100	I
10.152	90°	0.25	66.60	100	I
11.101	88°	3.00	65.45	100	I
11.145	88°	0.80	66.50	100	I
10.153	88°	0.25	66.50	100	I
11.201	85°	3.00	65.45	100	I
11.200	85°	0.80	66.50	100	I
11.853	85°	0.25	66.50	100	I

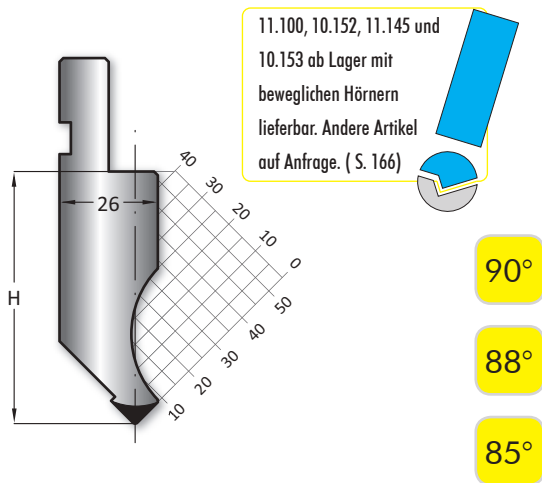

415 mm

835 mm

835 mm

	α	R	H	T/mt	Mt
10.175	90°	0.60	66.75	35	II
10.173	90°	0.25	66.70	35	II
10.176	88°	0.60	66.74	35	II
10.174	88°	0.25	66.70	35	II
10.170	85°	0.60	66.74	35	II
10.857	85°	0.25	67.00	35	II

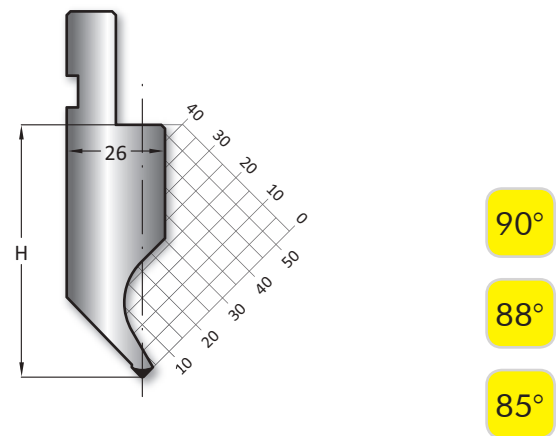

415 mm

835 mm

835 mm

	α	R	H	T/mt	Mt
11.870	88°	0.80	135.00	100	I
11.232	85°	0.80	135.00	100	I

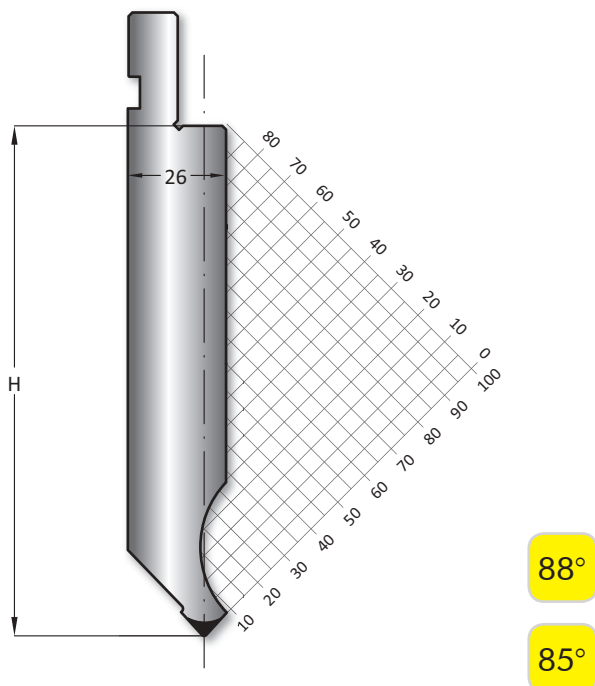

415 mm

835 mm

835 mm

	α	R	H	T/mt	Mt
11.228	88°	0.80	105.00	100	I
11.231	85°	3.00	105.00	100	I
11.230	85°	0.80	105.00	100	I

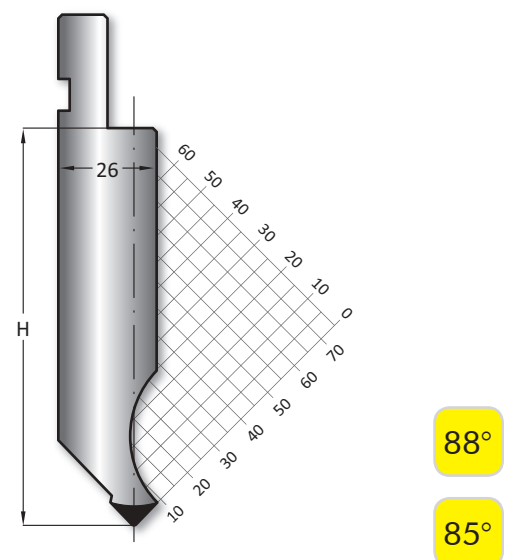

- 415 mm
- 835 mm
- 835 mm

	α	R	H	T/mt	Mt
10.261	90°	0.60	100.00	50	II
10.263	90°	0.25	100.00	50	II
10.262	88°	0.60	100.00	50	II
10.264	88°	0.25	100.00	50	II
10.626	85°	0.60	100.00	50	II
10.861	85°	0.25	100.00	50	II

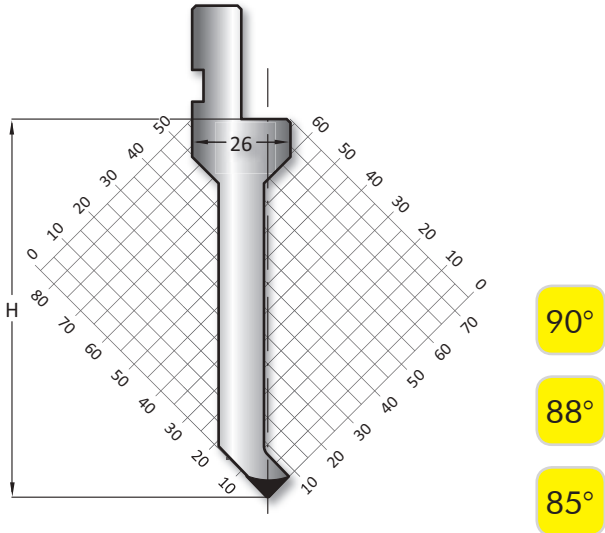

- 415 mm
- 835 mm
- 835 mm

	α	R	H	T/mt	Mt
11.858	88°	0.60	135.00	40	III
11.855	85°	0.60	135.00	40	III

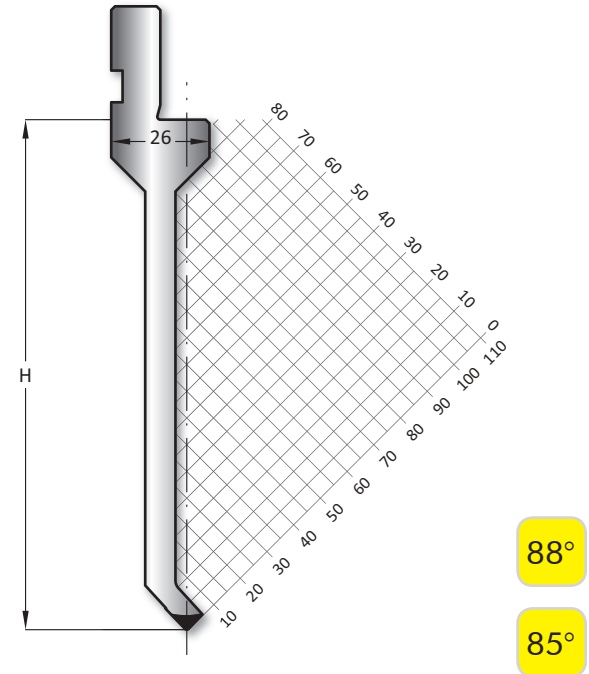

- 415 mm
- 835 mm
- 835 mm

	α	R	H	T/mt	Mt
10.259	90°	0.60	95.00	50	II
10.256	90°	0.25	95.00	50	II
10.260	88°	0.60	95.00	50	II
10.257	88°	0.25	95.00	50	II

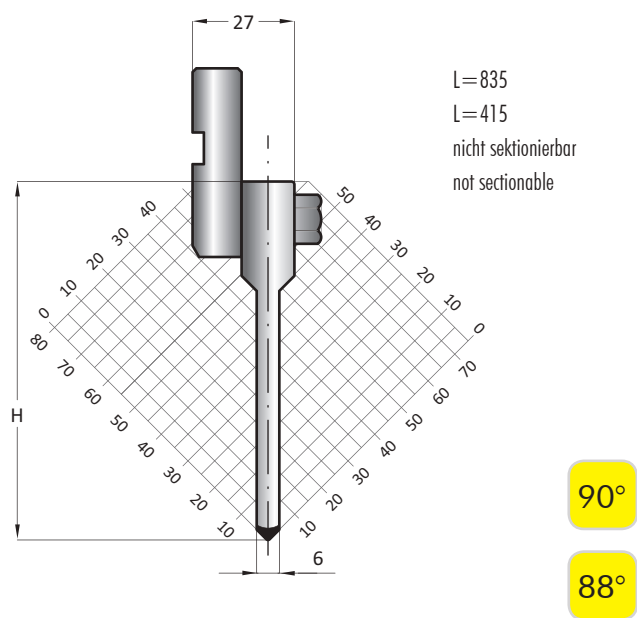

- 415 mm
- 835 mm
- 835 mm

	α	R	H	T/mt	Mt
10.503	90°	0.20	104.70	50	II
10.504	88°	0.80	104.50	50	II
11.650	85°	0.80	104.50	50	II
11.868	85°	0.25	104.70	50	II

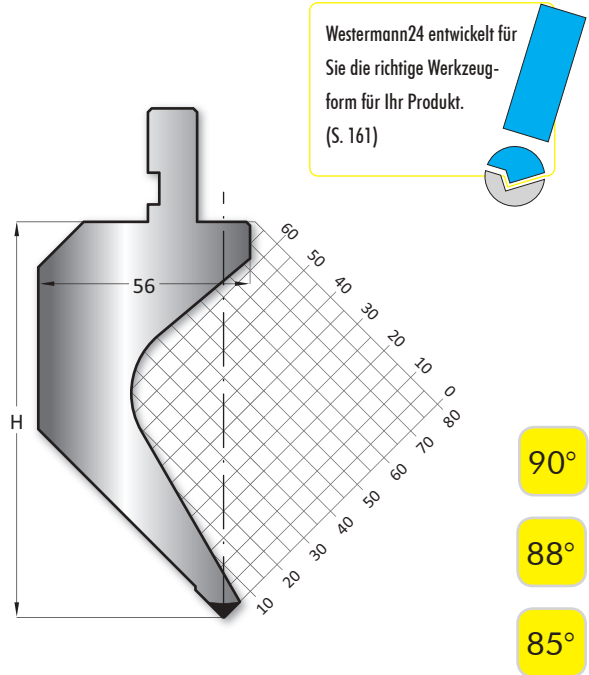

415 mm

835 mm

835 mm

	α	R	H	T/mt	Mt
10.501	90°	0.20	90.00	50	II
10.502	88°	0.80	89.70	50	II
11.865	85°	0.80	89.70	50	II

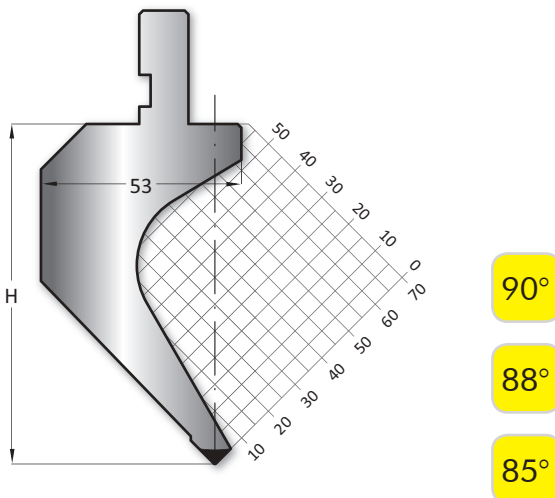

415 mm

835 mm

835 mm

	α	R	H	T/mt	Mt
11.107	90°	0.80	104.50	50	I
10.156	90°	0.25	104.50	50	I
11.108	88°	3.00	103.50	50	I
11.147	88°	0.80	104.50	50	I
10.157	88°	0.25	104.50	50	I
11.867	85°	0.25	104.50	50	I
11.866	85°	3.00	103.50	50	I
11.151	85°	0.80	104.50	50	I

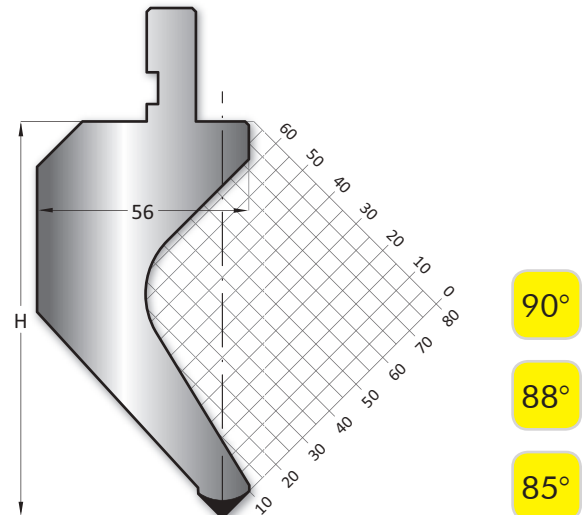

415 mm

835 mm

835 mm

	α	R	H	T/mt	Mt
11.105	90°	0.80	89.60	60	I
10.154	90°	0.25	89.60	60	I
11.106	88°	3.00	88.50	60	I
11.146	88°	0.80	89.58	60	I
10.155	88°	0.25	89.60	60	I
11.660	85°	0.80	89.58	60	I
11.863	85°	3.00	88.50	60	I
11.864	85°	0.25	89.70	60	I

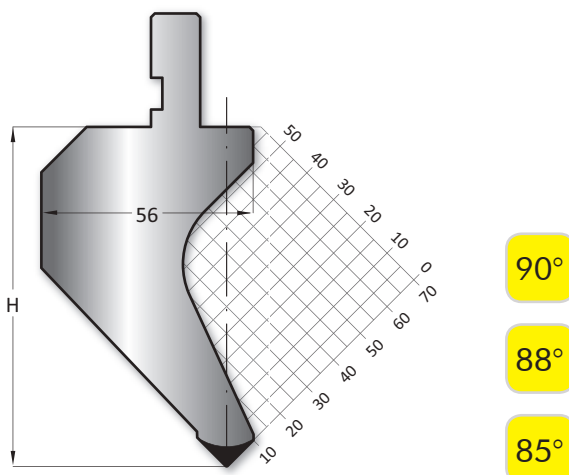

Westermann 24 liefert Ihnen
Oberwerkzeuge mit beweglichen
Hörnern.
Entweder fertig ab Lager, oder
individuell für Sie gefertigt.
(S. 166)



	α	R	H	T/mt	Mt
11.840	85°	1.00	185.00	60	II

505 mm

500 mm

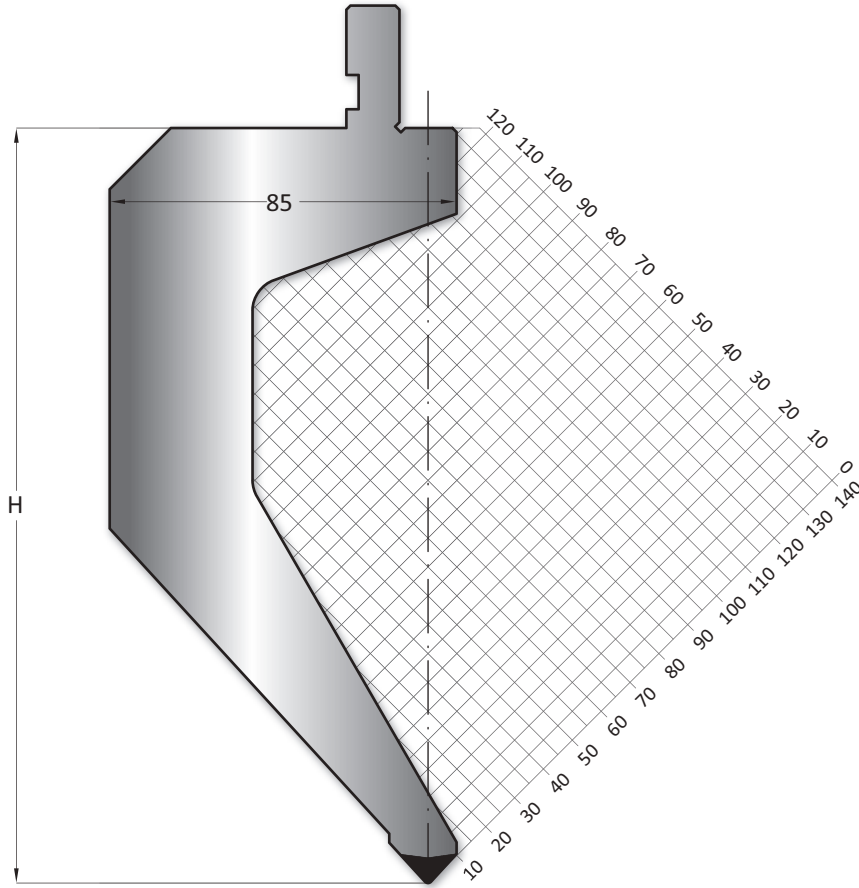

Standardlänge - Standard Length

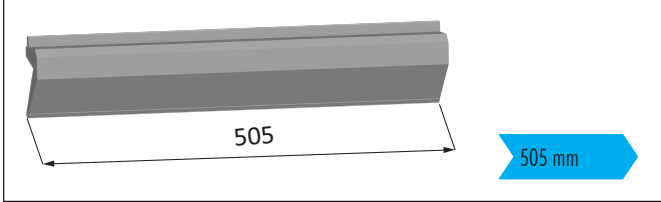

Horn Standard Teilung - Horns Scheme Standard Sectioning

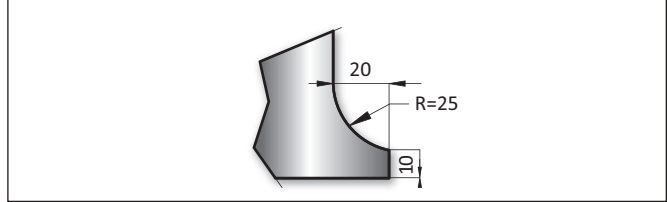

Geteilte Länge - Sectioned Length

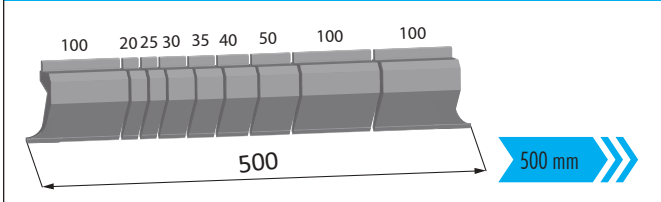

85°

	α	R	H	T/mt	Mt
11.800	85°	1.00	200.00	70	II

505 mm
500 mm

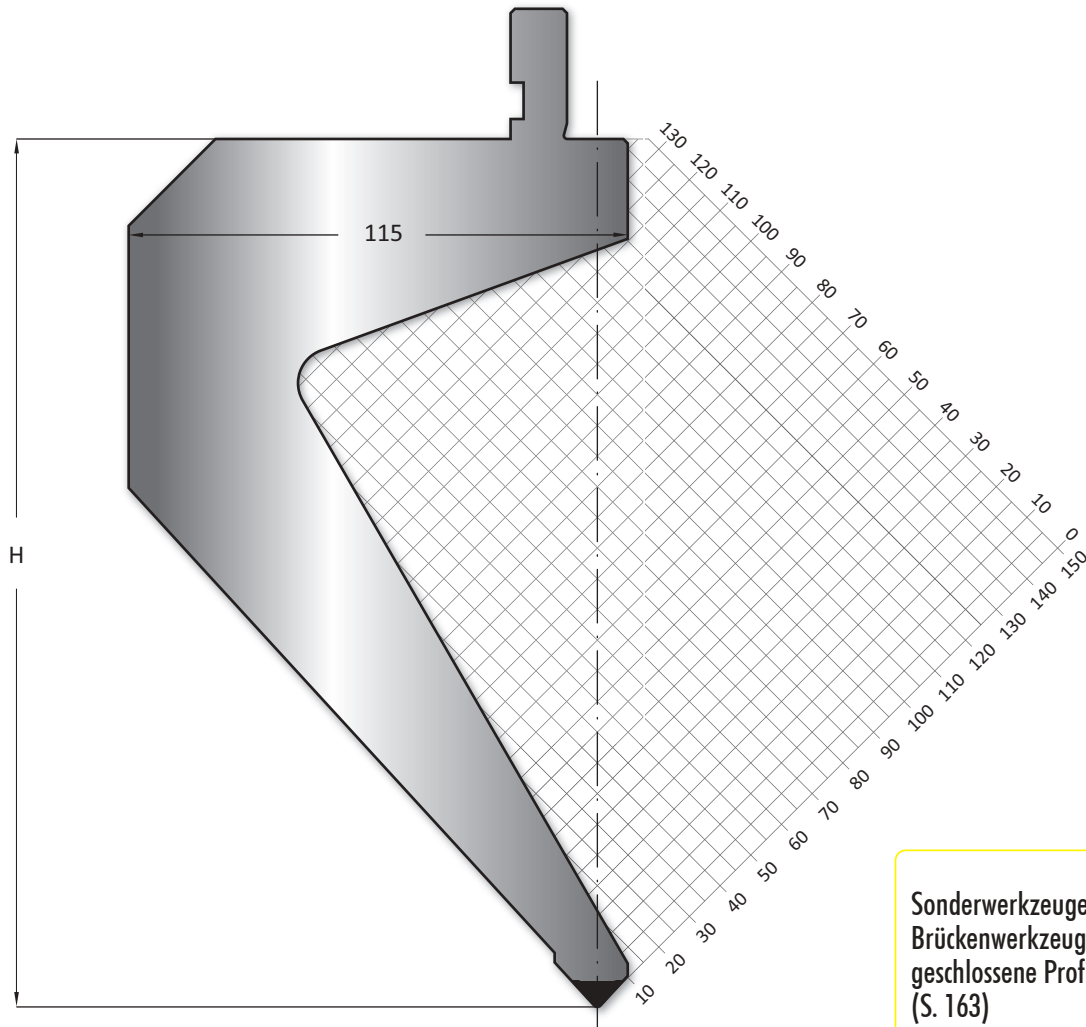

Standardlänge - Standard Length

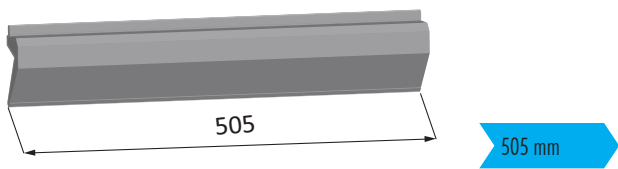

Horn Standard Teilung - Horns Scheme Standard Sectioning

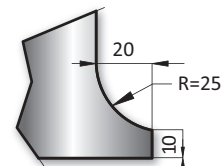

Geteilte Länge - Sectioned Length

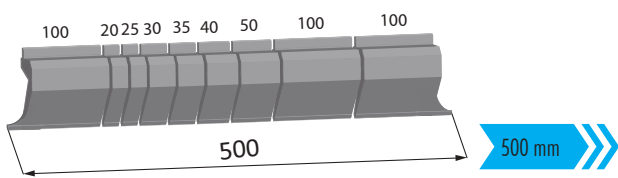

85°

- 415 mm
- 835 mm
- 835 mm

	α	R	H	T/mt	Mt
10.150	90°	0.60	84.13	20	III
10.512	88°	0.60	84.13	20	III

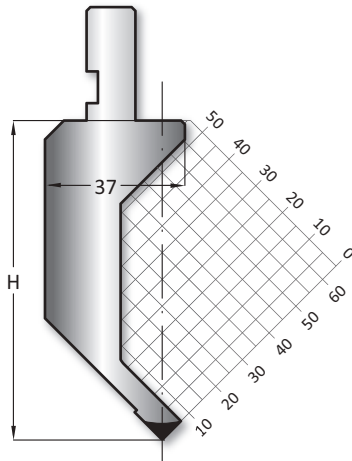

90°
88°

- 415 mm
- 835 mm
- 835 mm

	α	R	H	T/mt	Mt
10.505	88°	0.80	120.00	50	III
11.835	85°	0.80	120.00	50	III

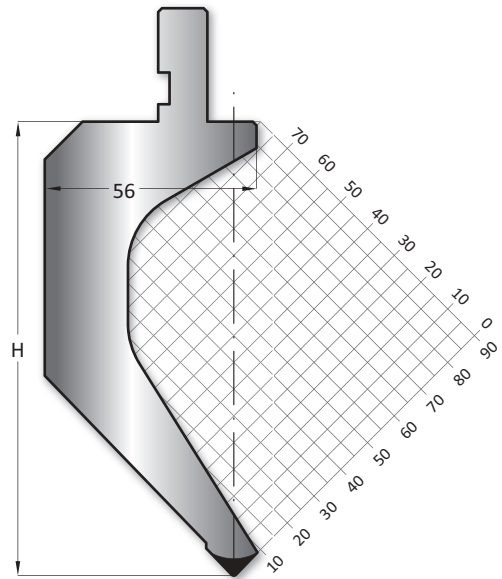

- 415 mm
- 835 mm
- 835 mm

	α	R	H	T/mt	Mt
11.670	85°	0.80	145.00	60	III

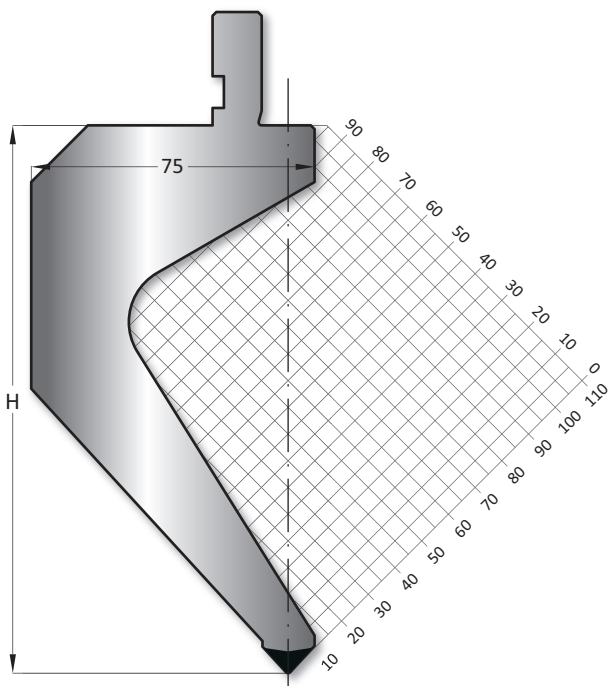

- 415 mm
- 835 mm
- 835 mm

	α	R	H	T/mt	Mt
11.233	88°	0.80	105.00	45	I
11.869	85°	0.80	105.00	45	I

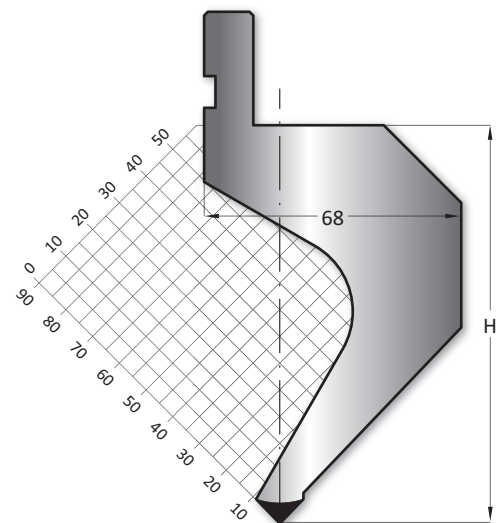

88°
85°

415 mm

835 mm

835 mm

	α	R	H	T/mt	Mt
11.149	88°	0.80	165.00	60	I
11.849	85°	0.80	165.00	60	I

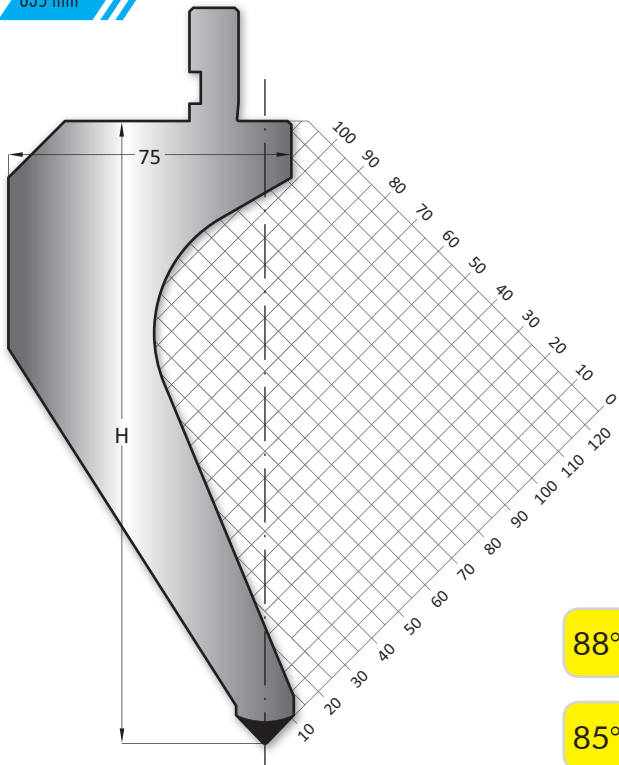

88°

85°

415 mm

835 mm

835 mm

	α	R	H	T/mt	Mt
11.148	88°	0.80	145.00	70	I
11.848	85°	0.80	145.00	70	I

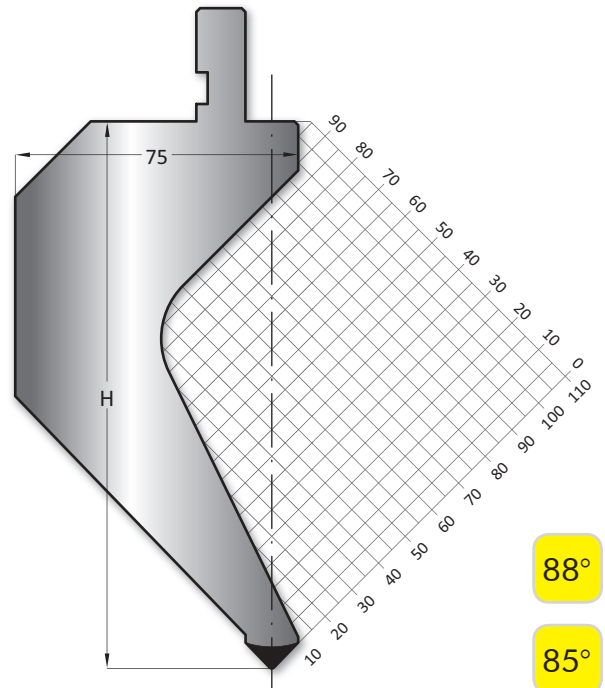

88°

85°

415 mm

835 mm

835 mm

	α	R	H	T/mt	Mt
11.830	88°	0.60	85.00	15	III

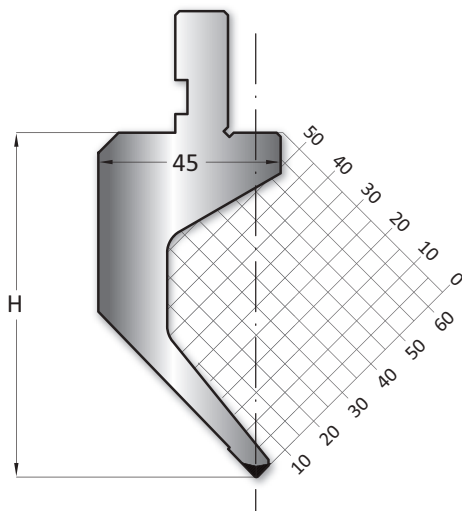

88°

415 mm

835 mm

835 mm

	α	R	H	T/mt	Mt
11.820	85°	0.60	115.00	20	III

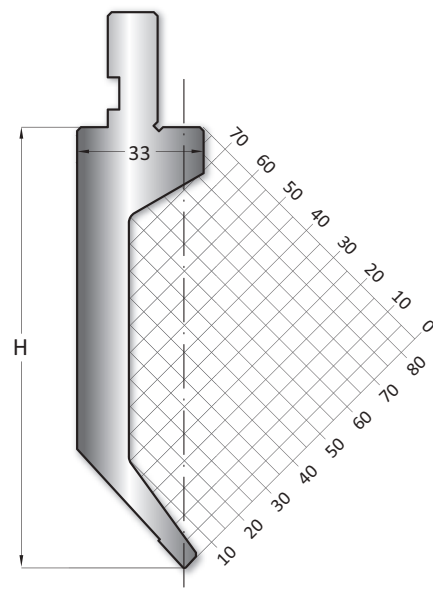

85°

- 415 mm
- 835 mm
- 835 mm

	α	R	H	T/mt	Mt
10.520	60°	0.80	115.00	50	II

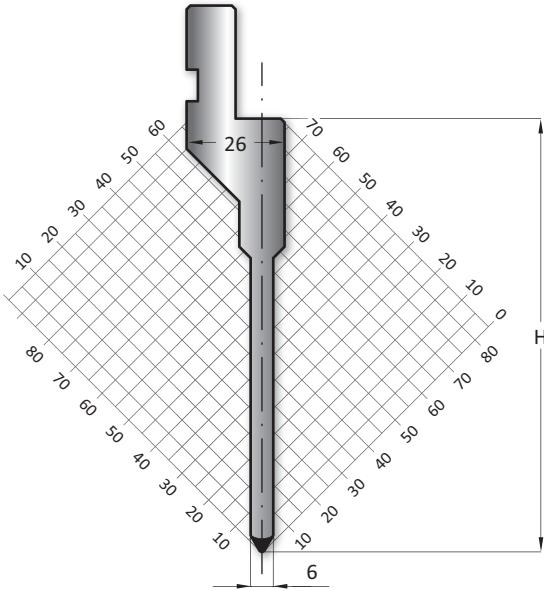

60°

- 415 mm
- 835 mm
- 835 mm

	α	R	H	T/mt	Mt
10.510	60°	0.80	115.00	60	II

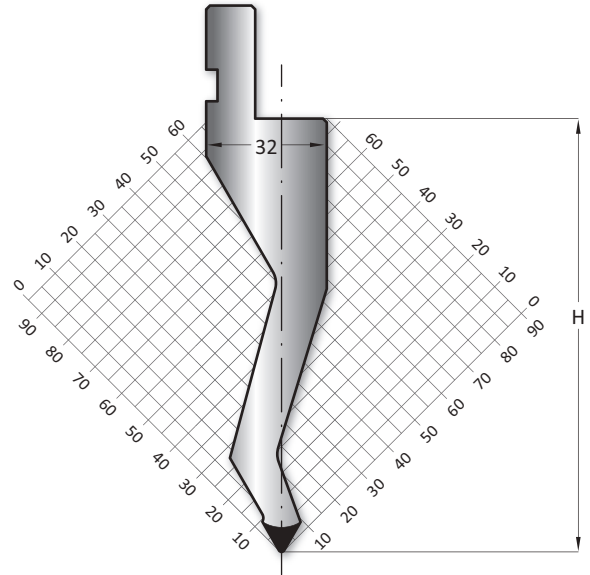

60°

- 415 mm
- 835 mm
- 835 mm

	α	R	H	T/mt	Mt
11.506	60°	0.80	130.00	40	II

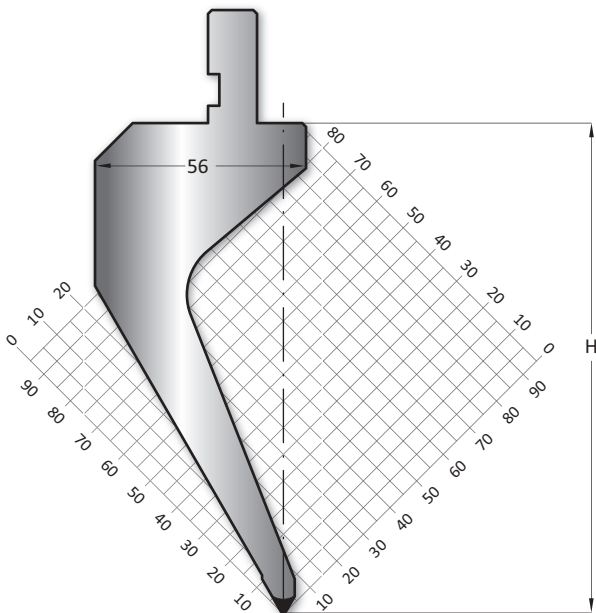

60°

	α	R	H
1.01.279	60°	1.00	165.00

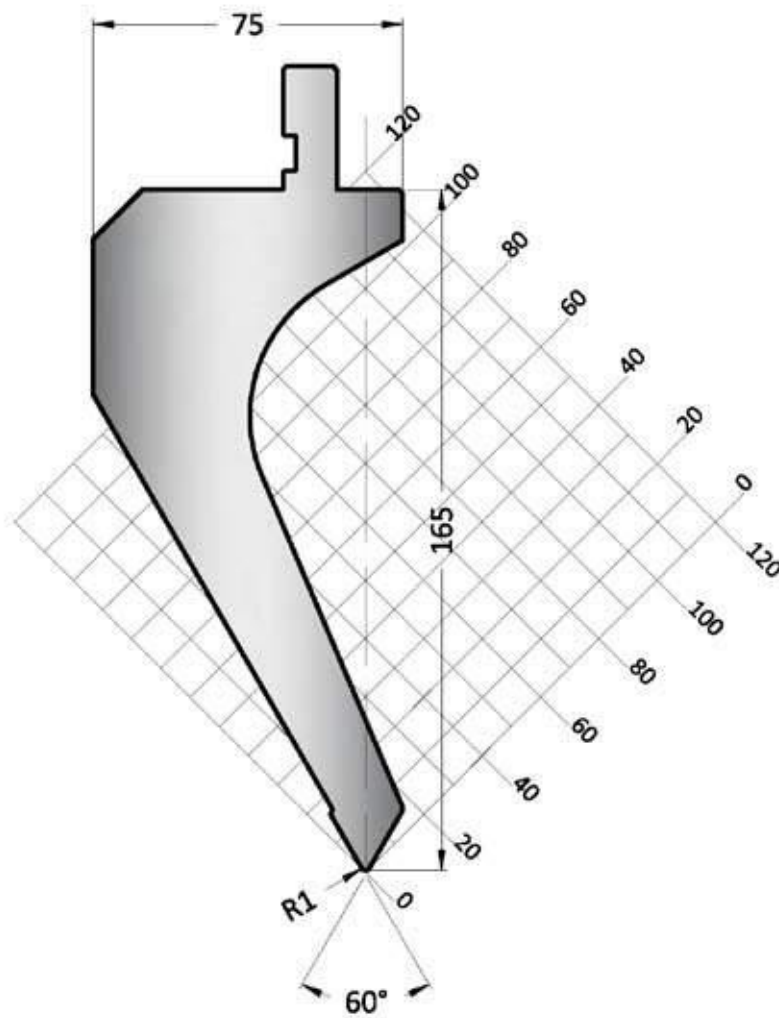

60°

- 415 mm
- 835 mm
- 835 mm

	α	R	H	T/mt	Mt
10.500	60°	0.80	115.00	40	II

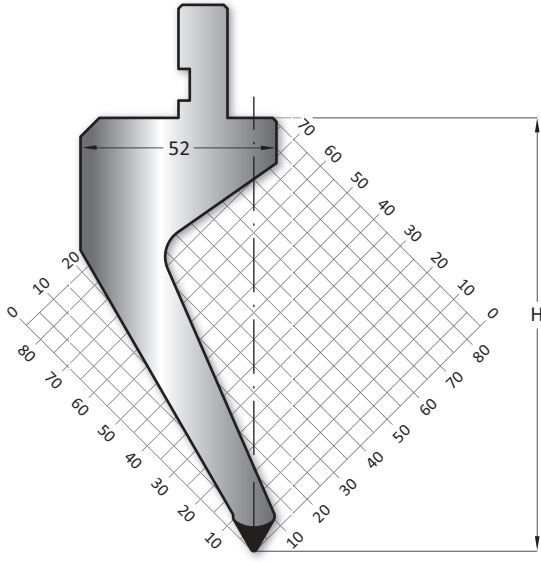

60°

- 415 mm
- 835 mm
- 835 mm

	α	R	H	T/mt	Mt
10.516	60°	0.80	85.00	40	II

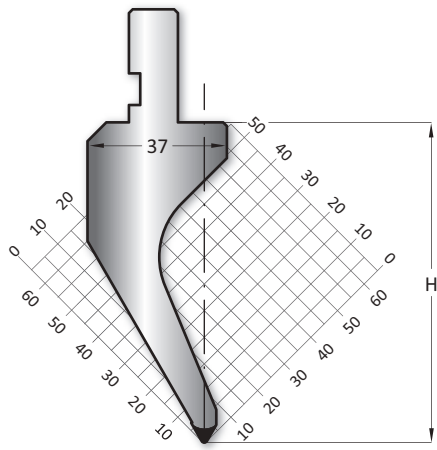

60°

- 415 mm
- 835 mm
- 835 mm

	α	R	H	T/mt	Mt
10.143	60°	2.00	65.80	60	I
10.142	60°	0.80	67.00	60	I

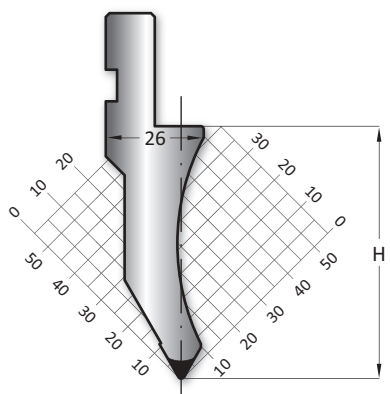

60°

- 415 mm
- 835 mm
- 835 mm

	α	R	H	T/mt	Mt
10.517	60°	0.80	80.00	25	III

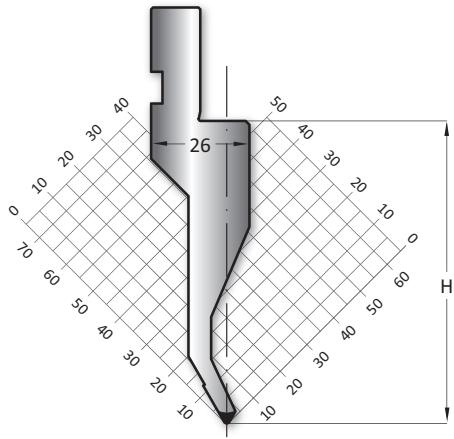

60°

415 mm

835 mm

835 mm

	α	R	H	T/mt	Mt
10.136	60°	6.00	65.00	100	I

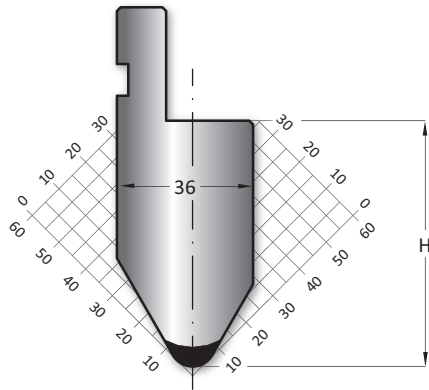

60°

415 mm

835 mm

835 mm

	α	R	H	T/mt	Mt
10.710	60°	5.00	115.00	100	I
10.720	60°	10.00	115.00	100	I

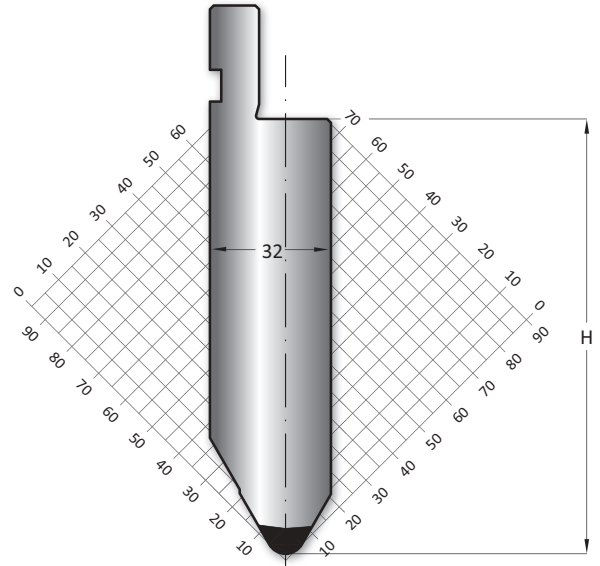

60°

415 mm

835 mm

835 mm

	α	R	H	T/mt	Mt
11.750	60°	0.80	135.00	60	I

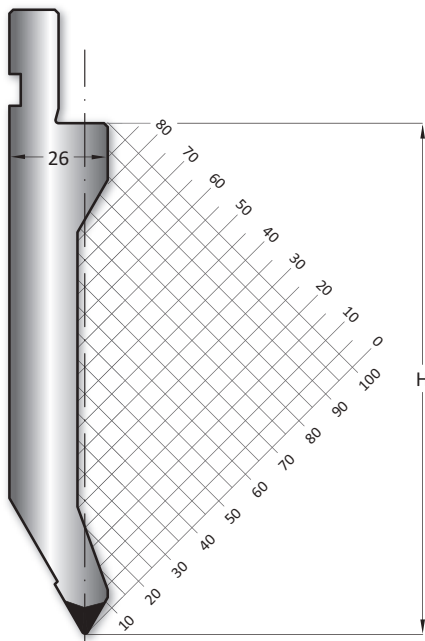

60°

415 mm

835 mm

835 mm

	α	R	H	T/mt	Mt
10.514	30°	0.60	80.00	50	III

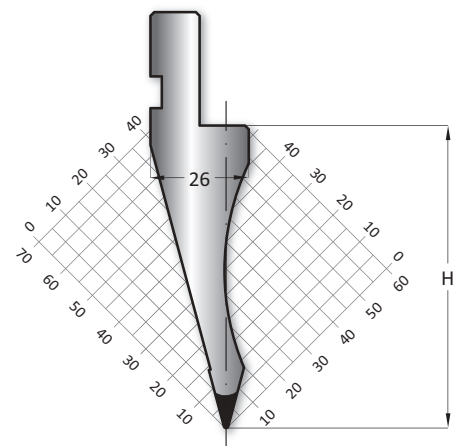

30°

Orange Line

- 415 mm
- 835 mm
- 835 mm

	α	R	H	T/mt	Mt
10.515	30°	0.60	140.00	50	III

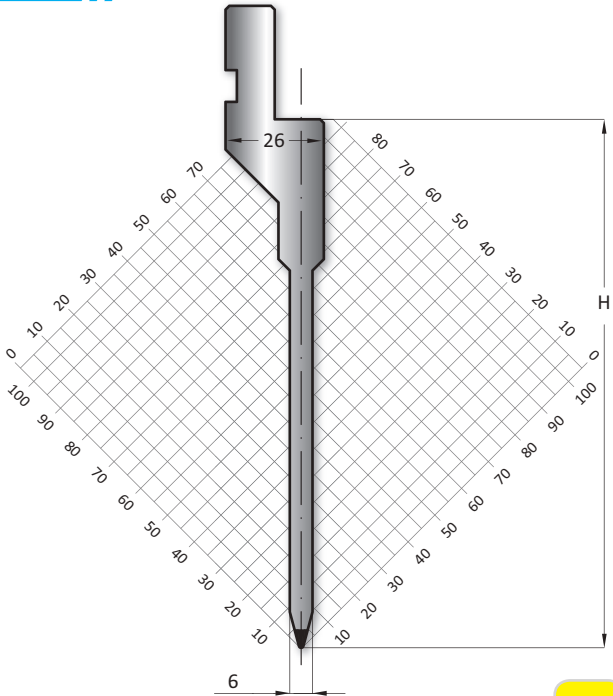

30°

- 415 mm
- 835 mm
- 835 mm

	α	R	H	T/mt	Mt
11.780	30°	0.50	135.00	80	I

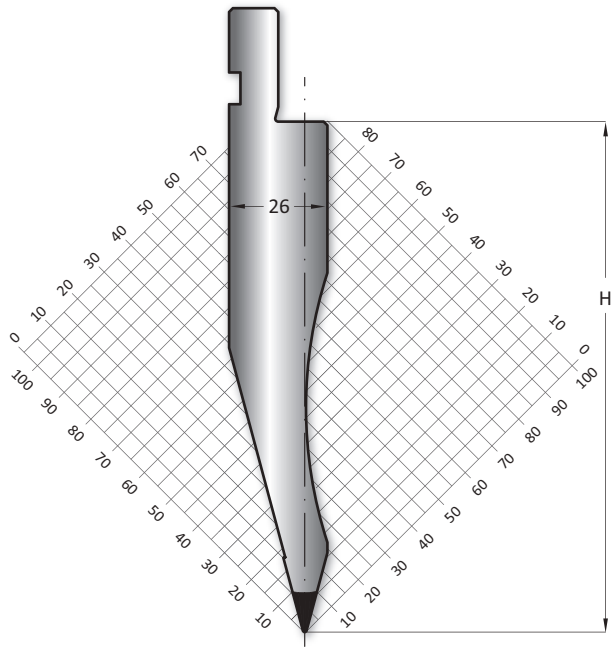

30°

- 415 mm
- 835 mm
- 835 mm

	α	R	H	T/mt	Mt
11.158	30°	0.60	80.00	100	I
10.511	30°	3.00	80.00	100	I

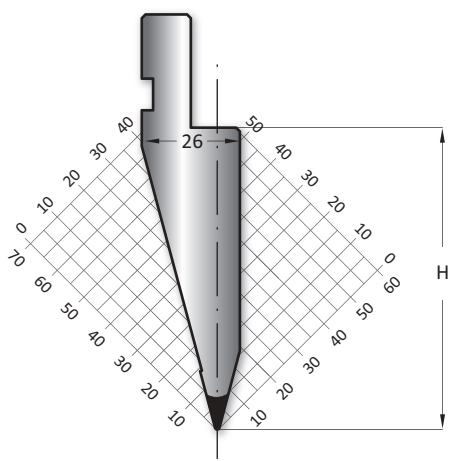

30°

415 mm

835 mm

835 mm

	α	R	H	T/mt	Mt
11.258	30°	0.60	104.00	100	I
11.530	30°	5.00	104.00	100	I
11.528	30°	3.00	104.00	100	I

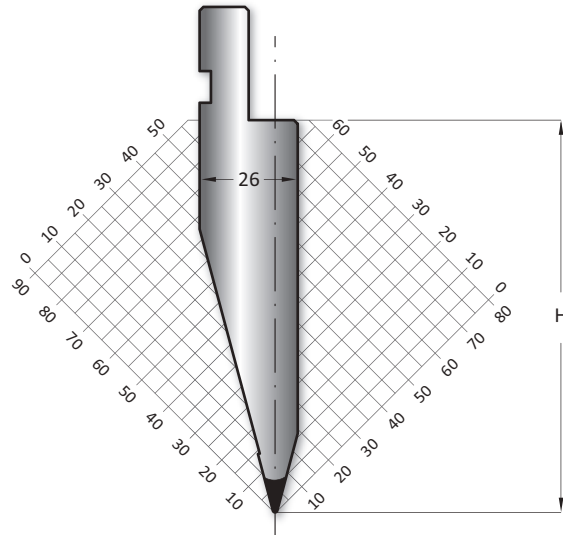

30°

415 mm

835 mm

835 mm

	α	R	H	T/mt	Mt
11.514	30°	0.60	104.00	50	III

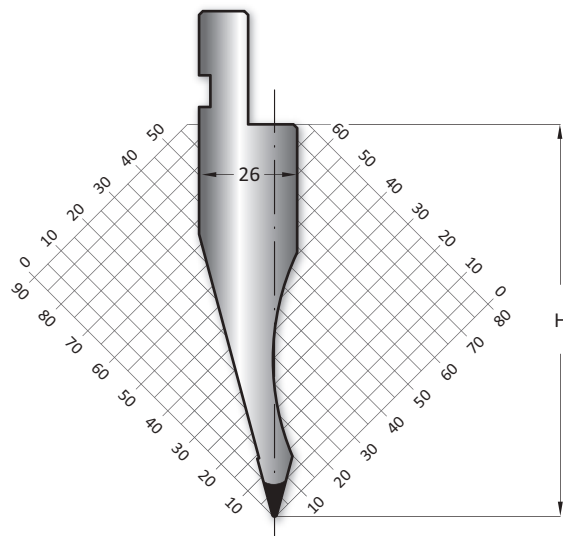

30°

- 415 mm
- 835 mm
- 835 mm

	α	R	H	T/mt	Mt
11.810	30°	1.00	200.00	50	II

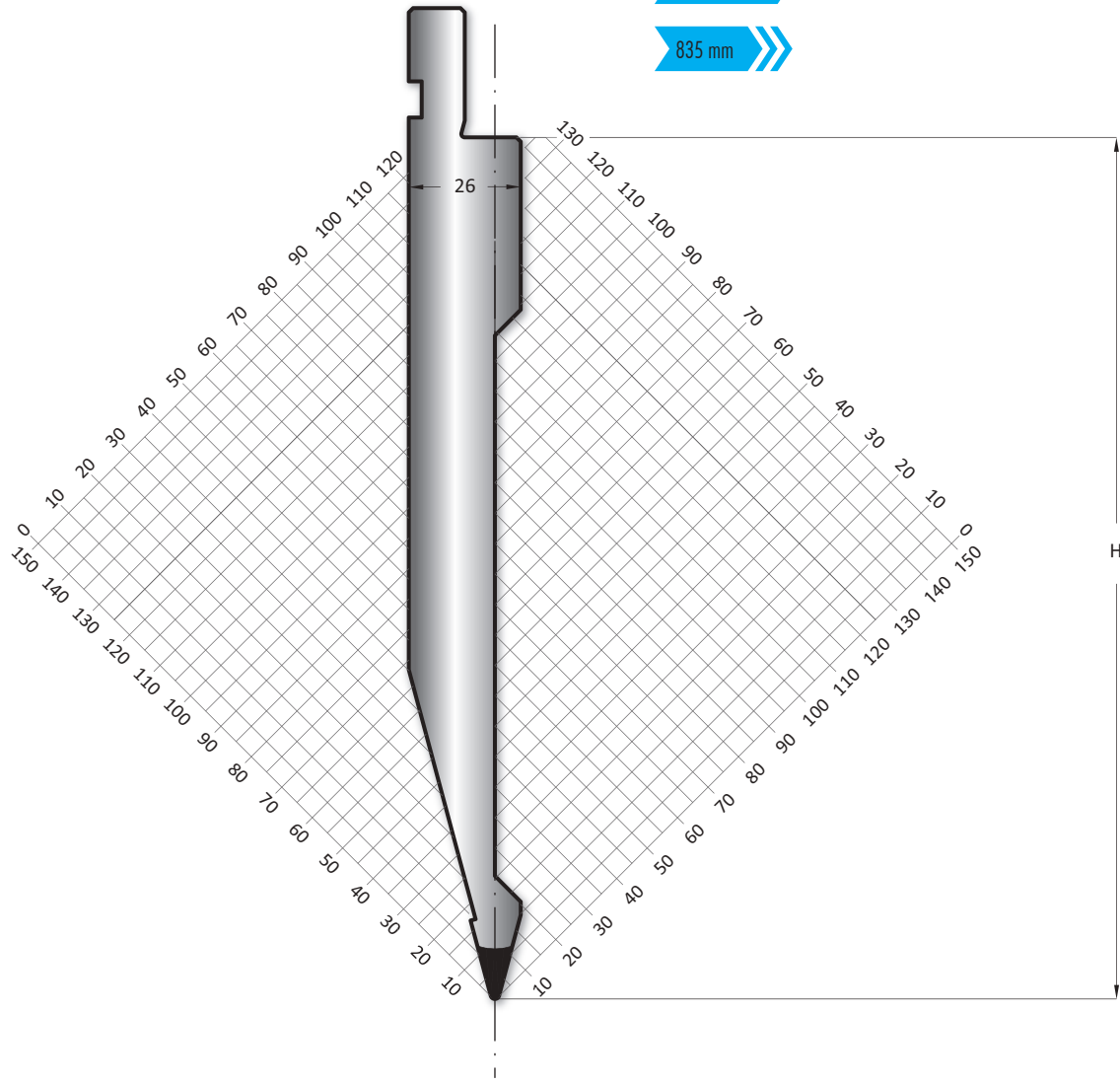

- 415 mm
- 835 mm
- 835 mm

	α	R	H	T/mt	Mt
11.540	26°	0.80	117.00	100	I

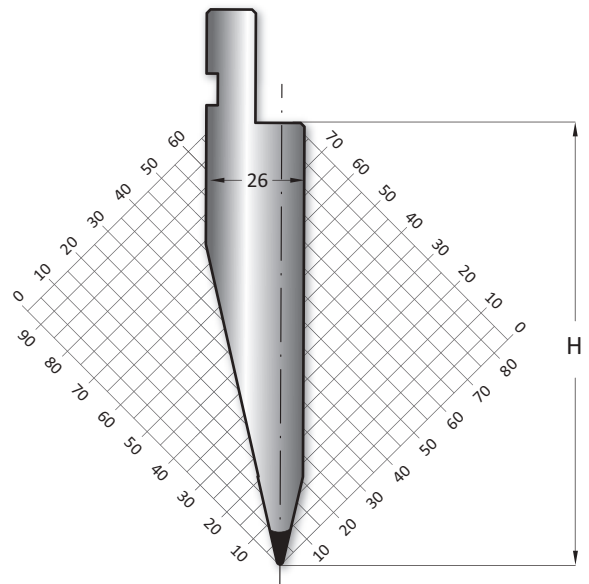

26°

Montagebeispiel - Assembly Scheme

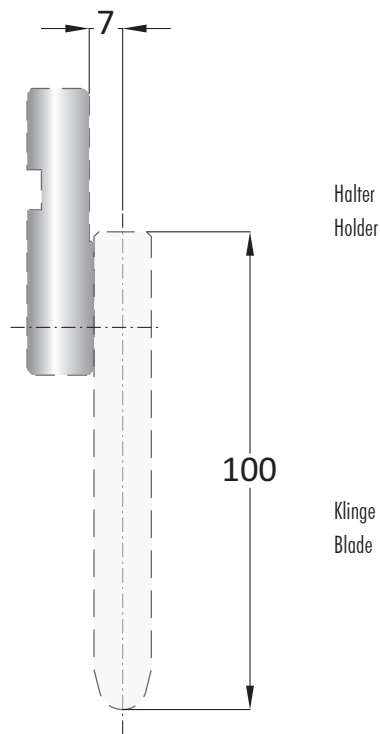

	H	Mt
10.400	60.00	I

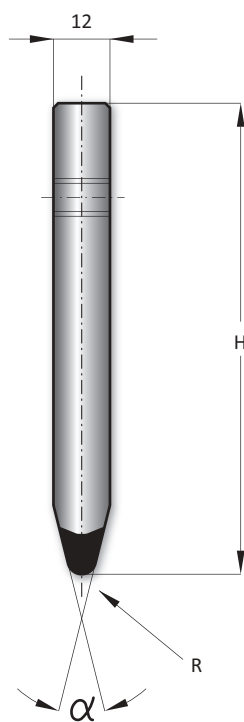
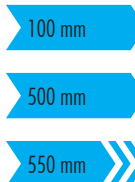
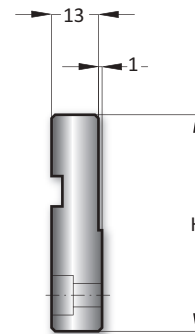
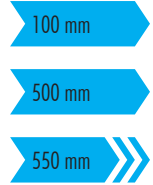

	α	R	H	T/mt	Mt
15.776	86°	1.00	100	100	III
15.774	84°	1.00	100	100	III
15.769	28°	6.00	100	100	III
15.768	28°	5.00	100	100	III
15.767	28°	4.00	100	100	III
15.766	28°	3.00	100	100	III
15.765	28°	2.00	100	100	III
15.763	28°	1.00	100	100	III
15.761	28°	0.50	100	100	III

86°

84°

28°

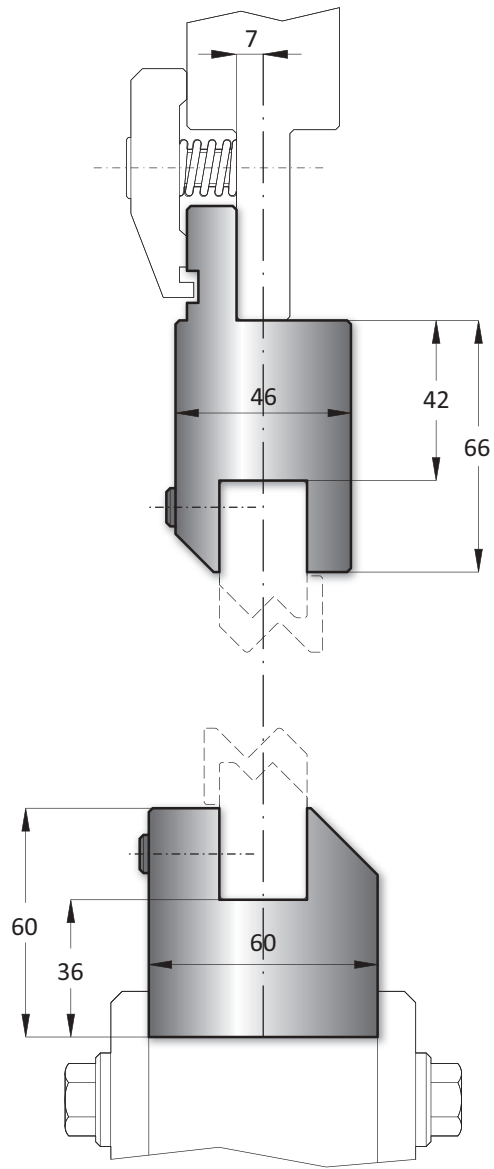

	T/mt	Mt
40.419	100	I

- ▶ 415 mm
- ▶ 835 mm

Montagebeispiel - Assembly Scheme

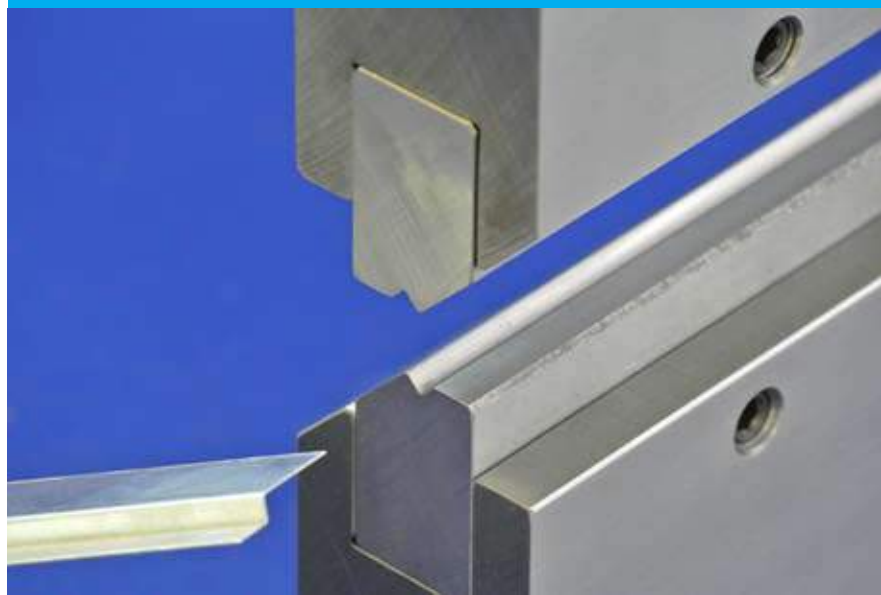

415 mm

835 mm

	Z	α	T/mt	Mt
40.510	1.00	160°	100	I
40.515	1.50	160°	100	I
40.520	2.00	150°	100	I
40.525	2.50	140°	100	I

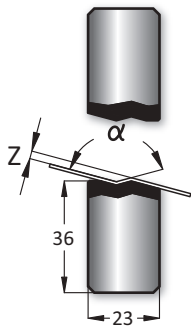

160°

150°

140°

415 mm

835 mm

	Z	α	T/mt	Mt
40.511	1.00	90°	100	I
40.516	1.50	90°	100	I
40.521	2.00	90°	100	I
40.526	2.50	90°	100	I
40.530	3.00	90°	100	I
40.535	3.50	90°	100	I
40.540	4.00	90°	100	I
40.545	4.50	90°	100	I
40.550	5.00	90°	100	I
40.555	5.50	90°	100	I
40.560	6.00	90°	100	I
40.565	6.50	90°	100	I
40.570	7.00	90°	100	I
40.575	7.50	90°	100	I
40.580	8.00	90°	100	I

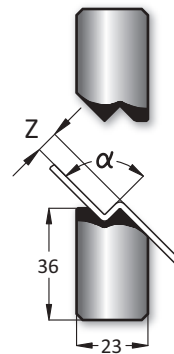

90°

415 mm

835 mm

	Z	α	T/mt	Mt
40.590	9.00	90°	100	I
40.610	10.00	90°	100	I
40.611	11.00	90°	100	I
40.612	12.00	90°	100	I

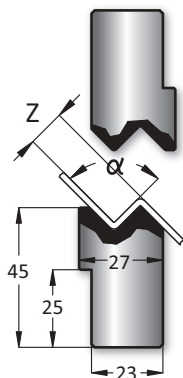

90°

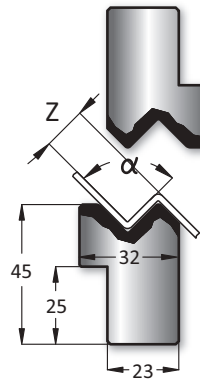

	Z	α	T/mt	Mt
40.613	13.00	90°	100	I
40.614	14.00	90°	100	I
40.615	15.00	90°	100	I

415 mm

835 mm

90°



	Z	α	T/mt	Mt
40.500				I

415 mm

835 mm

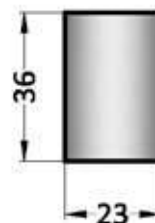

90°

Halbe Länge - Half Length

412 mm

Standardlänge - Standard Length

830 mm

Montagebeispiel - Assembly Scheme

R 3.0 Min R 5.0 Min
R 4.5 Max R 6.5 Max

Einsetzbar in kleiner V-Kerbe (A) oder großer V-Kerbe (B), je nach Radius
The inserts are mounted on A or B side depending on the type of radius

	T/mt	Mt
10.180	80	I

- 412 mm
- 830 mm

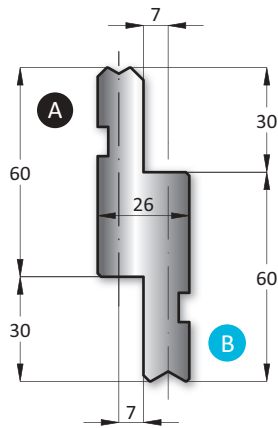

	R	V-Kerbe
10.181	3.00	A
10.182	3.50	A
10.183	4.00	A
10.184	4.50	A
10.185	5.00	B
10.186	5.50	B
10.187	6.00	B
10.188	6.50	B

- 415 mm
- 835 mm

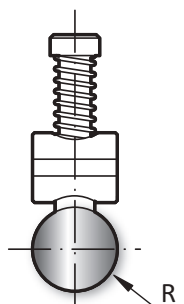

	H	T/mt	Mt
10.115	67.00	80	I

412 mm

830 mm

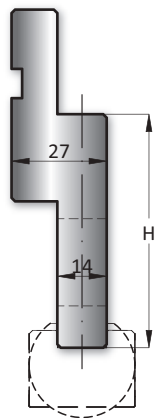

	H	T/mt	Mt
10.116	115.00	80	I

412 mm

830 mm

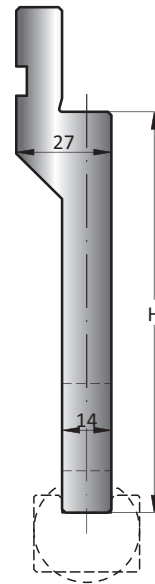

	H	T/mt	Mt
10.190	87.00	50	I

412 mm

830 mm

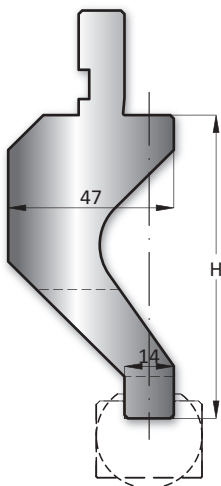

	H	T/mt	Mt
10.191	115.00	50	I

412 mm

830 mm

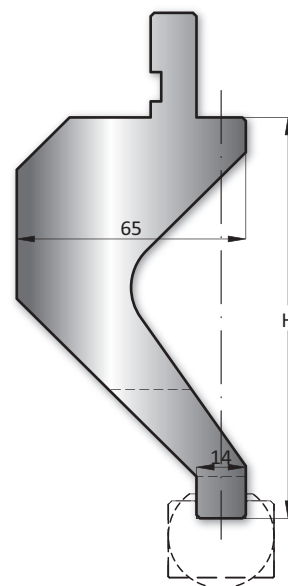

415 mm

835 mm

	R	A
10.300	7.00	11.50
10.301	7.50	11.50
10.302	8.00	13.00
10.303	9.00	16.00
10.304	10.00	16.00
10.305	11.00	16.00
10.306	11.50	19.00
10.307	12.00	20.00

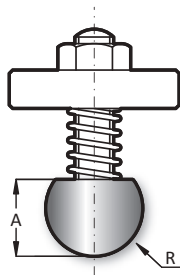

415 mm

835 mm

	R	A	B
10.308	12.50	16.00	21.00
10.309	13.00	17.00	23.00
10.310	14.00	19.00	25.00
10.311	15.00	20.00	27.00
10.312	16.00	21.00	28.00
10.313	17.00	21.50	31.50
10.314	17.50	22.00	32.00
10.315	19.00	25.00	32.00
10.316	20.00	24.00	34.00
10.317	22.50	25.00	33.00
10.318	25.00	29.00	39.00
10.319	27.50	34.00	44.00
10.320	30.00	34.00	44.00
10.321	35.00	45.00	55.00
10.322	40.00	45.00	55.00
10.323	45.00	50.00	60.00
10.324	50.00	54.00	64.00

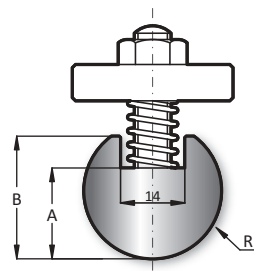

415 mm

835 mm

	A	B
10.325	17.00	22.00

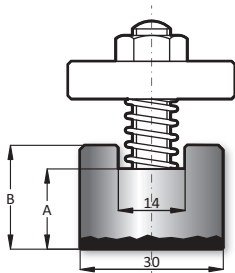

Westermann24 liefert
Ihnen Lösungen für
Halter mit Einsatz.
(S. 163)

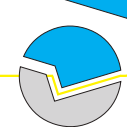

Unterwerkzeuge / Lower tools

direkt einsetzbar auf Abkantpressen von / directly able to work on bending presses of:

Amada, Atlantic, Adira, Bystronic-Beyeler Euro-B, CR-Electronic, Durmazlar, Ermaksan, Gasparini, Guifil, Haco, Imal, Mecos, Megobal, Promecam, SMD...



Orange Line

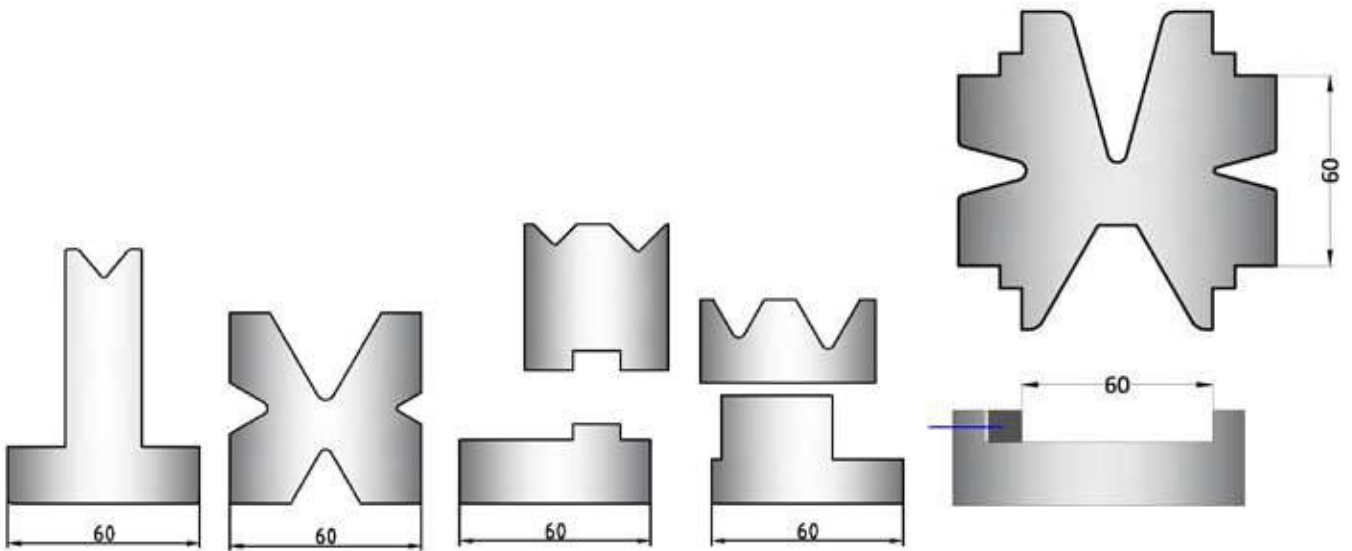

direkt einsetzbar auf Abkantpressen von:
Amada, Atlantic, Adira, Bystronic-Beyeler Euro-B,
CR-Electronic, Durmazlar, Ermaksan, Gasparini,
Guifil, Haco, Imal, Mecos, Megobal, Promecam,
SMD, u.v.m.

directly able to work on bending presses of:
Amada, Atlantic, Adira, Bystronic-Beyeler Euro-B,
CR-Electronic, Durmazlar, Ermaksan, Gasparini,
Guifil, Haco, Imal, Mecos, Megobal, Promecam,
SMD, and others

Material:

Westermann24 nutzt die vielfältigen Möglichkeiten der Werkstoffkunde, um Ihnen bestmögliche Qualität zu garantieren.

Verwendete Werkstoffe sind:

- I: C45
- II: C45, vergütet auf 800-850N/mm²
- III: 42CrMo4, vergütet auf 950-1050N/mm²
- Werkzeuge auf Anfrage: 1.2312, vergütet auf 1000-1200N/mm²

Ausführung:

Alle Biegeradien sind geschliffen und gehärtet

Werkzeuglängen:

Die Werkzeuglängen sind bei den Artikelnummern angegeben.
Artikelnummern ohne Längenangabe sind auf Anfrage.

sektionierte Werkzeugsätze:

Oberwerkzeuge:
OW 835mm sektioniert in : 10,15,20,40,50,200,300,100 Horn links, 100 Horn rechts

Unterwerkzeuge:
UW 835mm sektioniert in: 10,15,20,40,50,100,200,400

Belastbarkeit:

Die Belastbarkeit der Werkzeuge ist bei den Artikelnummern angegeben.
Werkzeuge die höher belastet werden sollen, können auf Anfrage konstruiert werden.
(siehe Seite 161)

material:

Westermann24 uses the many possibilities of the material engineering, to guarantee best quality.

used materials are:

- I: C45
- II: C45, tempered to 800-850N/mm²
- III: 42CrMo4, tempered to 950-1050N/mm²
- tools on request: 1.2312, tempered to 1000-1200N/mm²

design:

All radii are grinded and hardened

length of the tool:

The tool length are posted with the art-no.
Article- number without length- determination are available on request.

tool sets divided into sections:

Upper tool:
OW 835mm sectioned in : 10,15,20,40,50,200,300,100 horn left, 100 horn right

lower tool:
UW 835mm sectioned in: 10,15,20,40,50,100,200,400

loading capacity:

The loading capacity of the tools is specified by the article number.
Tools which will also be loaded more heavily, can be designed by agreement with the relevant application engineering. (see Page 161)

	H1	H2	T/mt	Mt
20.200	34.00	20.00	100	I
20.316	39.00	20.00	100	I
20.201	55.00	35.00	100	I
20.306	75.00	55.00	100	I

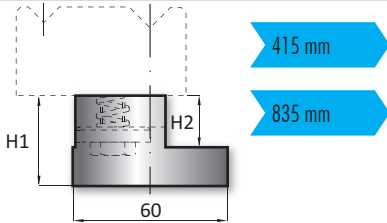

	H1	H2	T/mt	Mt
20.287	10.00	15.00	100	I

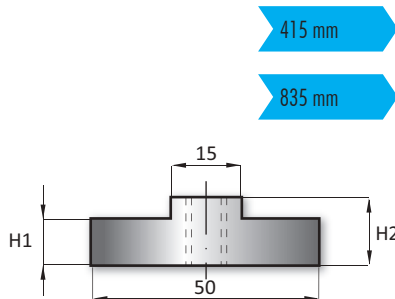

	H1	H2	T/mt	Mt
20.400	20.00	25.00	100	I

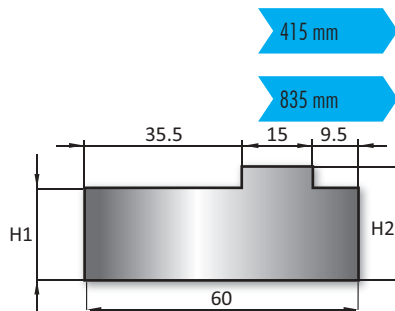

	H1	H2	Mt
20.336	20.00	25.00	I

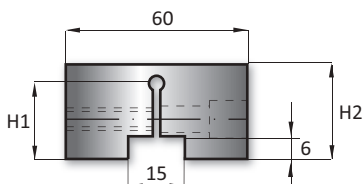

Montageanleitung - Assembly Instructions

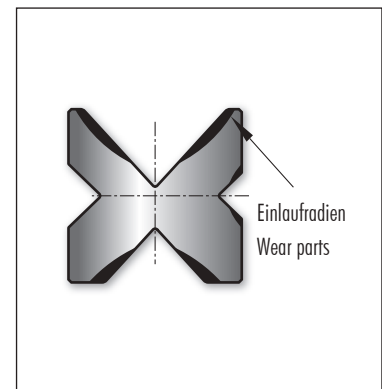
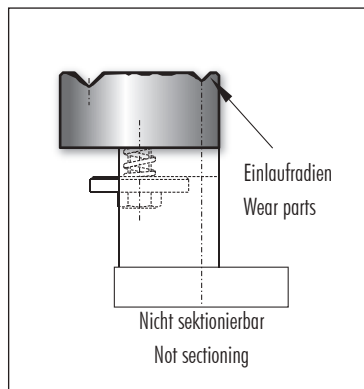
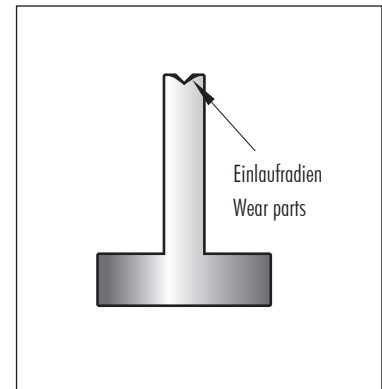
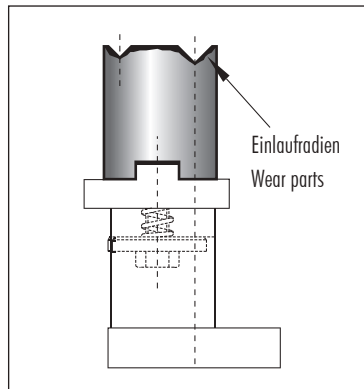

Montagebeispiel - Assembly Scheme

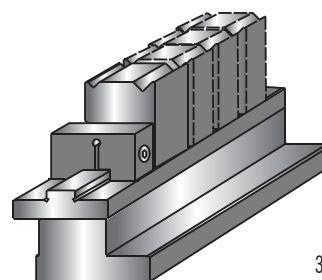
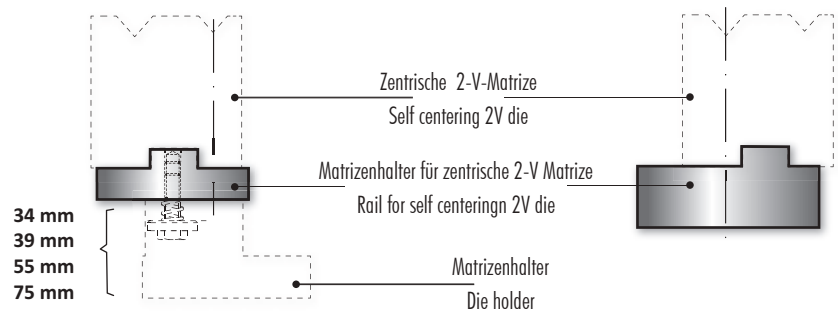

3D Ansicht
3D view

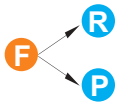

	α	V1	V2	R1	R2	F1	F2	L1	L2	H	B	C	T/mt	Mt
20.295	90°	4	7	0,3	0,5	R0,5	R0,5	4	7	26	55	44	100	I
20.202	90°	6	10	0,4	0,6	R0,5	R0,5	6	10	26	55	39	100	I
20.203	90°	8	12	0,5	0,8	R0,5	R0,5	8	10	26	55	37	100	I
21.202	88°	6	10	0,8	1,2	R0,5	R0,5	6	10	26	55	39	100	I
20.338	88°	8	12	1,0	1,5	R0,5	R0,5	8	10	26	55	37	100	I
20.204	88°	12	20	2,75	3,0	R0,5	R0,5	10	15	26	55	30	100	I
20.296	88°	14	18	2,75	3,0	R0,5	R0,5	11	13	26	55	31	100	I
20.205	88°	16	25	2,75	3,0	R0,5	R0,5	12	16,5	26	55	26,5	100	I
20.235	60°	6	10	0,4	0,6	R0,5	R0,5	6	10	26	55	39	60	I
20.229	60°	8	12	0,5	0,8	R0,5	R0,5	8	10	26	55	37	60	I
20.230	60°	12	20	0,8	1,5	R0,5	R0,5	10	15	26	55	30	60	I
20.267	60°	16	20	1,6	2,0	R0,7	R0,7	12	15	26	55	28	60	I
20.418	30°	8	12	0,8	1,5	P2,0	P2,0	9,5	14,5	46	50	26	40	I

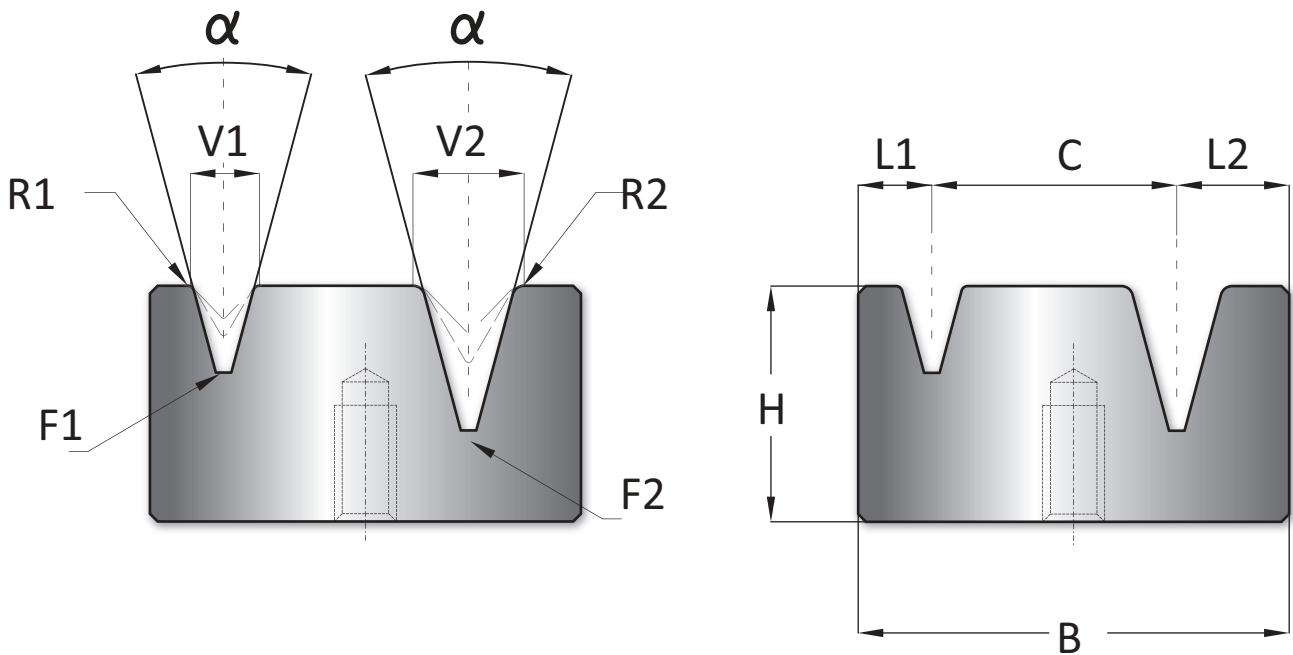

90°

88°

60°

30°

Legende - Legend	Technik - technique
F = Nutgrund - ground of the groove	
R = radius	
P = flach - flat	

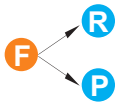

	α	V1	V2	R1	R2	F1	F2	L1	L2	H	B	C	T/mt	Mt
20.275	90°	4	7	0,3	0,5	R0,5	R0,5	3,5	5	46	34,5	26	80	I
20.276	90°	6	10	0,4	0,6	R0,5	R0,5	4,5	6,5	46	37	26	80	I
20.277	90°	8	12	0,5	0,8	R0,5	R0,5	5,5	7,5	46	39	26	80	I
21.275	88°	4	7	0,6	1,0	R0,5	R0,5	3,5	5	46	34,5	26	80	I
21.276	88°	6	10	0,8	1,2	R0,5	R0,5	4,5	6,5	46	37	26	80	I
20.339	88°	8	12	1,0	1,5	R0,5	R0,5	5,5	7,5	46	39	26	80	I
20.279	88°	12	20	0,8	1,75	R0,5	R0,5	7,5	12	46	45,5	26	80	I
20.278	88°	14	18	1,25	1,5	R0,5	R0,5	8,5	10,5	46	45	26	80	I
20.280	88°	16	25	1,5	1,75	R0,5	R0,5	9,5	14,5	46	50	26	80	I
20.344	85°	4	7	0,6	1,0	R0,5	R0,5	3,5	5	46	34,5	26	80	I
20.345	85°	6	10	1,0	1,5	R0,5	R0,5	4,5	6,5	46	37	26	80	I
20.346	85°	8	12	1,2	1,75	R0,7	R0,7	5,5	7,5	46	39	26	80	I
20.347	85°	12	20	1,75	2,5	R0,5	R0,5	7,5	12	46	45,5	26	80	I
20.349	85°	14	18	1,5	2,0	R0,7	R0,7	8,5	10,5	46	45	26	80	I
20.348	85°	16	25	2,0	3,0	R0,5	R0,5	9,5	14,5	46	50	26	80	I
20.438	30°	10	10	0,6	1,0	R1,0	P2,0	7	12	46	45	26	40	I
20.478	30°	12	12	0,8	1,5	P2,0	P2,0	9,5	14,5	46	50	26	40	I

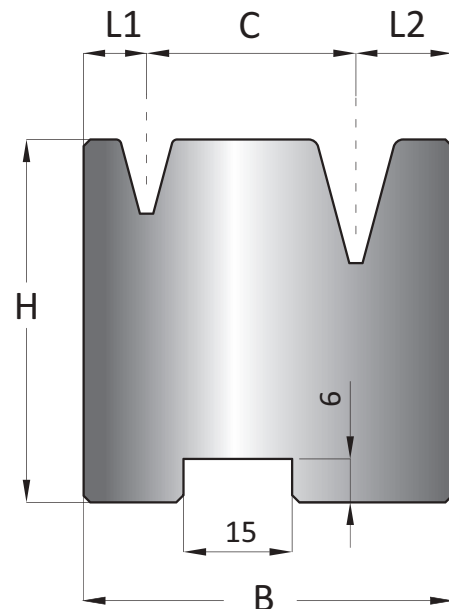
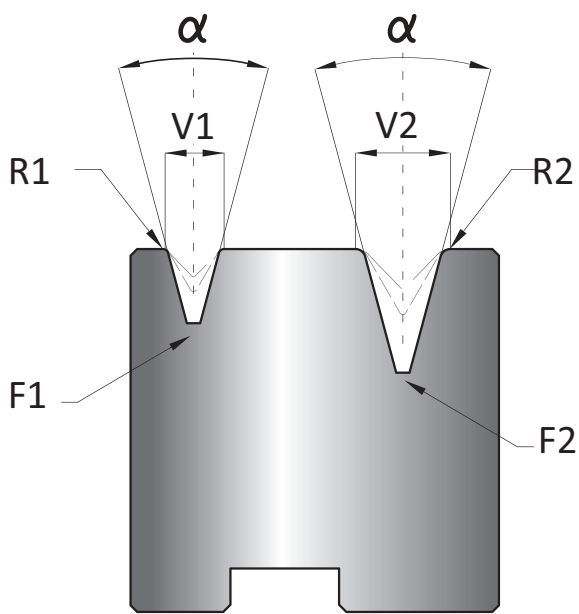
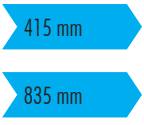

Legende - Legend	Technik - technique
F = Nutgrund - ground of the groove	
R = radius	
P = flach - flat	

- 90°
- 88°
- 85°
- 30°

Orange Line

	α	T/mt	Mt
20.208	90°	80	I

415 mm
835 mm
835 mm

90°

	α	T/mt	Mt
20.237	90°	80	I

415 mm
835 mm
835 mm

90°

	T/mt	Mt
21.209	100	I

415 mm
835 mm
835 mm

	α	T/mt	Mt
20.350	60°	60	I

415 mm
835 mm
835 mm

60°

	α	T/mt	Mt
21.207	85°	80	I

415 mm
835 mm
835 mm

85°

	α	H	T/mt	Mt
20.820	85°	80.00	100	I

415 mm
835 mm
835 mm

85°

	α	H	T/mt	Mt
20.830	30°	80.00	100	I

415 mm
835 mm
835 mm

30°

	α	H	T/mt	Mt
2.14.309				

415 mm
835 mm
835 mm

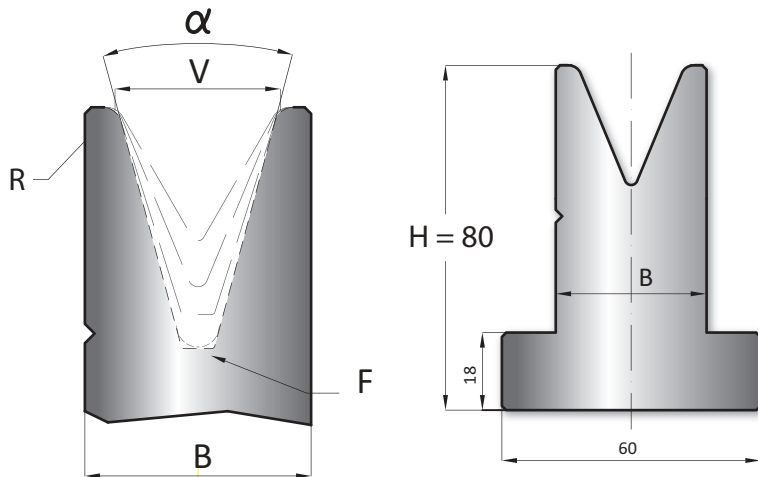

H=80

415 mm

835 mm

835 mm

Passende
Adapterschiene
auf S 182

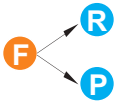

90°	V	R	B	F	T/mt	Mt
20.243	6	0,4	14	R 0,5	100	I
20.258	8	0,5	14	R 0,5	100	I
20.244	10	0,6	18	R 0,5	100	I
20.245	12	0,8	18	R 0,5	100	I
20.246	16	1,0	24	R 0,5	100	I

85°	V	R	B	H	T/mt	Mt
20.210	32	4.00	60	60.00	100	I
20.211	40	4.00	60	60.00	100	I
20.212	50	4.00	60	60.00	100	I
20.213	63	5.00	80	75.00	100	I
20.214	80	6.00	95	80.00	100	I
20.215	100	7.00	120	95.00	100	I

88°	V	R	B	F	T/mt	Mt
20.806	6	0,8	14	R 0,5	100	I
20.808	8	1,0	14	R 0,5	100	I
20.810	10	1,2	18	R 0,5	100	I
20.371	12	1,5	18	R 0,5	100	I
20.327	16	2,0	24	R 0,5	100	I
20.310	20	2,0	30	R 1,0	100	I
20.309	25	3,0	35	R 1,0	100	I

80°	V	R	H	T/mt	Mt
2.13.320	16				
2.13.321	20				
2.13.322	24				
2.13.323	30				
2.13.324	35				
2.13.325	40				
2.13.326	50				
2.13.327	60				
20.216	125	9.00	103.00	100	I
20.217	160	10.00	130.00	100	I
20.125	125	9.00	103.00	100	I
20.160	160	10.00	130.00	100	I



85°	V	R	B	F	T/mt	Mt
20.506	6	1,5	14	R 0,5	100	I
20.508	8	2,0	14	R 0,5	100	I
20.510	12	2,5	18	R 0,5	100	I
20.512	12	3,0	18	R 0,5	100	I
20.516	16	3,5	24	R 0,5	100	I
20.520	20	4,0	30	R 1,0	100	I
20.525	25	5,0	35	R 1,0	100	I

90°

88°

85°

80°

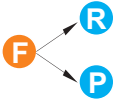

60°	V	R	B	F	T/mt	Mt
20.297	6	0,4	14	R 0,5	60	I
20.298	8	0,5	14	R 0,5	60	I
20.299	10	0,6	18	R 0,5	60	I
20.300	12	0,8	18	R 0,5	60	I
20.301	16	1,6	24	R 0,7	60	I
20.308	20	2,0	30	R 1,0	60	I
20.311	25	3,0	35	R 1,0	60	I

35°	V	R	B	F	T/mt	Mt
20.406	6	1,5	14	R 1,0	40	I
20.408	8	2,0	18	P 2,0	40	I
20.410	10	2,5	24	P 2,0	55	I
20.412	12	3,0	24	P 2,0	45	I
20.416	16	3,5	30	P 2,0	50	I
20.420	20	4,0	35	P 5,0	60	I
20.425	25	5,0	40	P 5,0	60	I

60°	V	R	B	H	T/mt	Mt
2.13.315	30					
2.13.316	35					
2.13.317	40					
20.650	50	5.00	75	75.00	100	I
20.370	63	5.00	86	86.00	100	I
20.680	80	6.00	115	115.00	100	I



30°	V	R	B	F	T/mt	Mt
20.317	6	0,6	14	R 1,0	35	I
20.318	8	0,8	18	P 2,0	35	I
20.319	10	1,0	24	P 2,0	50	I
20.320	12	1,5	24	P 2,0	40	I
20.321	16	2,0	30	P 5,0	45	I
20.322	20	2,5	35	P 5,0	50	I
20.323	25	3,0	40	P 5,0	50	I

45°	V	R	B	F	T/mt	Mt
20.328	6	0,6	14	R 0,8	50	I
20.329	8	0,8	18	R 0,8	50	I
20.330	10	1,0	18	R 0,8	50	I
20.331	12	1,5	24	R 0,8	50	I
20.332	16	2,0	24	R 1,5	50	I
20.333	20	2,5	30	R 1,5	50	I
20.334	25	3,0	35	R 1,5	50	I

30°	V	R	B	H	T/mt	Mt
2.13.310	30					
2.13.311	35					
20.494	18	2.00	60	60.00	100	I
20.325	25	3.00	60	60.00	100	I



45°	V	R	B	H	T/mt	Mt
20.484	32	4.00	60	80.00	100	I
20.440	40	4.00	75	75.00	100	I
20.380	80	6.00	145	145.00	100	I

60°

45°

35°

30°

Legende - Legend	Technik - technique
	F = Nutgrund - ground of the groove
	R = radius
	P = flach - flat

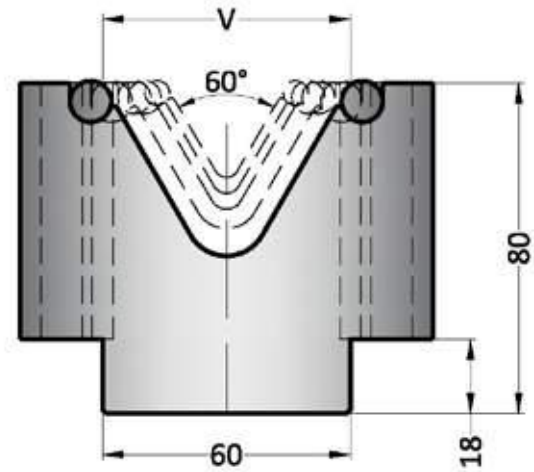

Westermann-T - mit Einlaufwellen 60°

	V	α	H
2.22.010	30	60°	80.00
2.22.011	35	60°	80.00
2.22.012	40	60°	80.00
2.22.013	50	60°	80.00
2.22.014	60	60°	80.00



60°

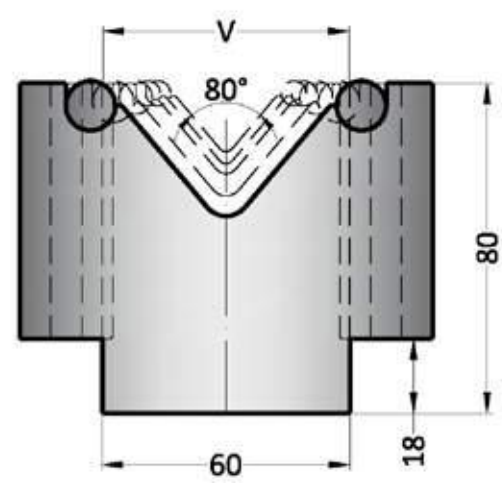

Westermann-T - mit Einlaufwellen 80°

	V	α	H
2.22.015	30	80°	80.00
2.22.016	35	80°	80.00
2.22.017	40	80°	80.00
2.22.018	50	80°	80.00
2.22.019	60	80°	80.00



Passende
Adapterschiene
auf S 182

80°

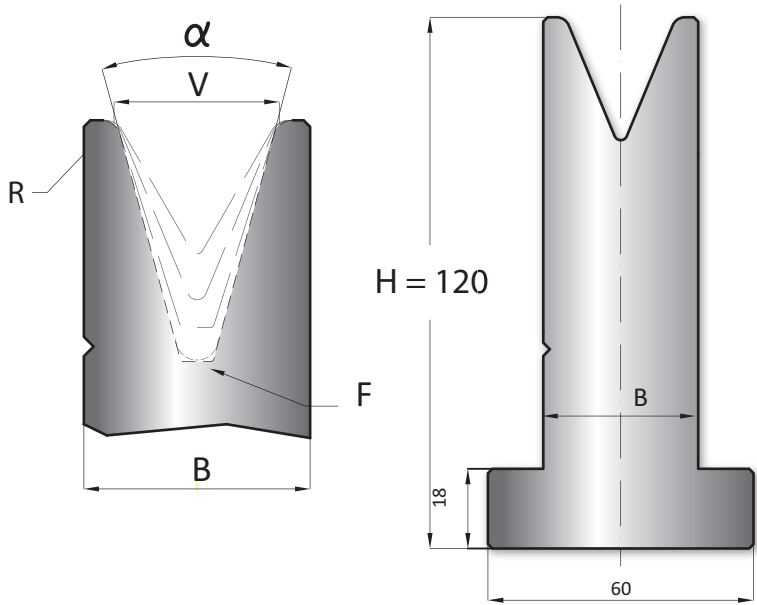

H = 120

- 415 mm
- 835 mm
- 835 mm

Legende - Legend	Technik - technique
F	= untere Matrize - bottom die
R	= radius
P	= flach - flat

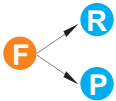

90°	V	R	B	F	T/mt	Mt
20.361	6	0,4	14	R 0,5	100	I
20.362	8	0,5	14	R 0,5	100	I
20.363	10	0,6	18	R 0,5	100	I
20.364	12	0,8	18	R 0,5	100	I
20.381	16	1,0	24	R 0,5	100	I

85°	V	R	B	H	T/mt	Mt
20.210	32	4.00	60	60.00	100	I
20.211	40	4.00	60	60.00	100	I
20.212	50	4.00	60	60.00	100	I
20.213	63	5.00	80	75.00	100	I
20.214	80	6.00	95	80.00	100	I
20.215	100	7.00	120	95.00	100	I

88°	V	R	B	F	T/mt	Mt
21.806	6	0,8	14	R 0,5	100	I
21.808	8	1,0	14	R 0,5	100	I
21.810	10	1,2	18	R 0,5	100	I
20.382	12	1,5	18	R 0,5	100	I
20.383	16	2,0	24	R 0,5	100	I
20.384	20	2,0	30	R 1,0	100	I
20.385	25	3,0	35	R 1,0	100	I

80°	V
2.14.324	16
2.14.325	20
2.14.326	24
2.14.327	30
2.14.328	35
2.14.329	40
2.14.330	50
2.14.331	60
2.14.332	80
2.14.333	100
2.14.334	120

Passende
Adapterschiene
auf S 182

85°	V	R	B	F	T/mt	Mt
21.506	6	1,5	14	R 0,5	100	I
21.508	8	2,0	14	R 0,5	100	I
21.510	12	2,5	18	R 0,5	100	I
21.512	12	3,0	18	R 0,5	100	I
21.516	16	3,5	24	R 0,5	100	I
21.520	20	4,0	30	R 1,0	100	I
21.525	25	5,0	35	R 1,0	100	I

80°	V	R	H	T/mt	Mt
20.216	125	9.00	103.00	100	I
20.217	160	10.00	130.00	100	I
20.125	125	9.00	103.00	100	I
20.160	160	10.00	130.00	100	I

- 90°
- 88°
- 85°
- 80°

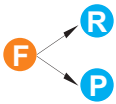

60°	V	R	B	F	T/mt	Mt
20.386	6	0,4	14	R 0,5	60	I
20.387	8	0,5	14	R 0,5	60	I
20.388	10	0,6	18	R 0,5	60	I
20.389	12	0,8	18	R 0,5	60	I
20.390	16	1,6	24	R 0,7	60	I
20.391	20	2,0	30	R 1,0	60	I
20.392	25	3,0	35	R 1,0	60	I

35°	V	R	B	F	T/mt	Mt
21.406	6	1,5	14	R 1,0	40	I
21.408	8	2,0	18	P 2,0	40	I
21.410	10	2,5	24	P 2,0	55	I
21.412	12	3,0	24	P 2,0	45	I
21.416	16	3,5	30	P 2,0	50	I
21.420	20	4,0	35	P 5,0	60	I
21.425	25	5,0	40	P 5,0	60	I

60°	V	R	B	H	T/mt	Mt
2.14.316	30					
2.14.317	35					
2.14.318	40					
20.650	50	5,0	75	75	100	I
20.370	63	5,0	86	86	100	I
20.680	80	6,0	115	115	100	I
2.14.322	100					
2.14.323	120					



30°	V	R	B	F	T/mt	Mt
20.351	6	0,6	14	R 1,0	35	I
20.352	8	0,8	18	P 2,0	35	I
20.353	10	1,0	24	P 2,0	50	I
20.354	12	1,5	24	P 2,0	40	I
20.401	16	2,0	30	P 5,0	45	I
20.402	20	2,5	35	P 5,0	50	I
20.403	25	3,0	40	P 5,0	50	I

30°	V	R	B	H	T/mt	Mt
2.14.310	30					
2.14.311	35					
2.14.312	40					
20.494	18	2,0	60	60	100	I
20.325	25	3,0	60	60	100	I



45°	V	R	B	F	T/mt	Mt
20.393	6	0,6	14	R 0,8	50	I
20.394	8	0,8	18	R 0,8	50	I
20.395	10	1,0	18	R 0,8	50	I
20.396	12	1,5	24	R 0,8	50	I
20.397	16	2,0	24	R 1,5	50	I
20.398	20	2,5	30	R 1,5	50	I
20.399	25	3,0	35	R 1,5	50	I

45°	V	R	B	H	T/mt	Mt
20.484	32	4,0	60	80	100	I
20.440	40	4,0	75	75	100	I
20.380	80	6,0	145	145	100	I

60°

45°

35°

30°

Legende - Legend	Technik - technique
	F = Nutgrund - ground of the groove
	R = radius
	P = flach - flat

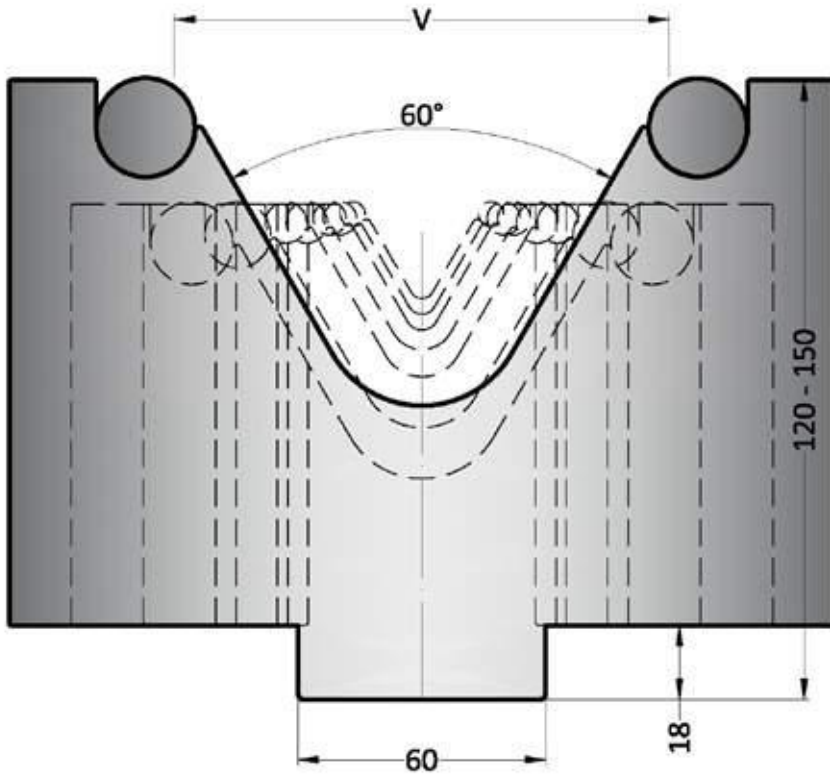

	V	α	H
2.23.011	30	60°	120.00
2.23.012	35	60°	120.00
2.23.013	40	60°	120.00
2.23.014	50	60°	120.00
2.23.015	60	60°	120.00
2.23.016	80	60°	120.00
2.23.017	100	60°	120.00
2.23.018	120	60°	120.00



Westermann 24 liefert Ihnen Matrizen mit Welleneinsatz. (S. 162)

Westermann-T - mit Einlaufwellen 60°

60°

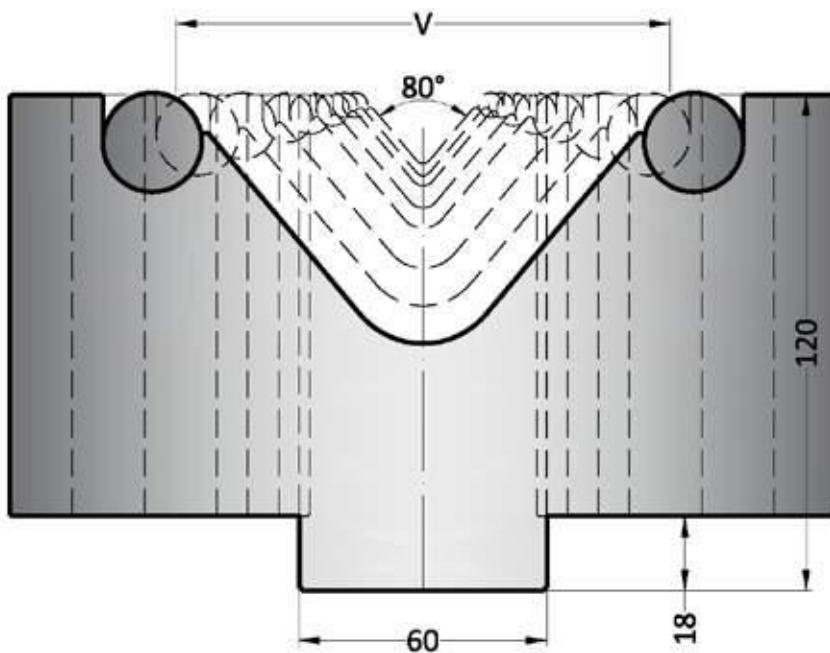

	V	α	H
2.23.019	30	80°	120.00
2.23.020	35	80°	120.00
2.23.021	40	80°	120.00
2.23.022	50	80°	120.00
2.23.023	60	80°	120.00
2.23.024	80	80°	120.00
2.23.025	100	80°	120.00
2.23.026	120	80°	120.00



Westermann-T - mit Einlaufwellen 80°

80°

	Mt
22.010	I

415 mm

835 mm

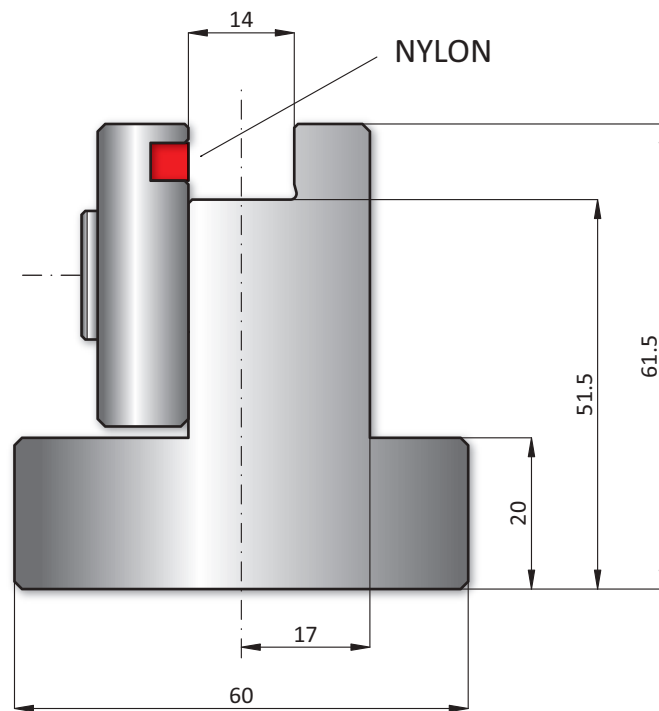

Montagebeispiel - Assembly Scheme

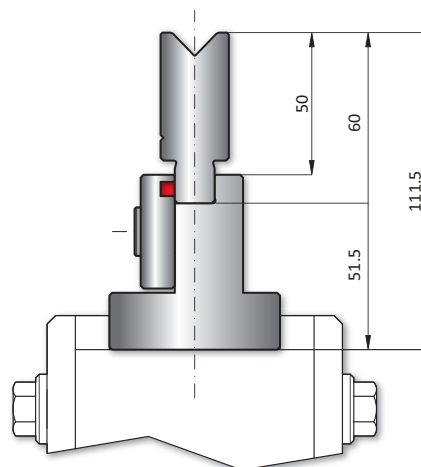

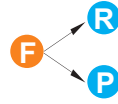

	α	V	A	B	R	F	T/mt	Mt
22.804	88°	4	60	14	0,6	R 0,5	100	I
22.806	88°	6	60	14	0,8	R 0,5	100	I
22.808	88°	8	60	14	1,0	R 0,5	100	I
22.810	88°	10	60	18	1,2	R 0,5	100	I
22.812	88°	12	60	18	1,5	R 0,5	100	I
22.816	88°	16	60	24	2,0	R 0,5	100	I
22.820	88°	20	60	30	2,0	R 1,0	100	I
22.825	88°	25	60	35	3,0	R 1,0	100	I
22.306	30°	6	60	14	0,6	R 1,0	35	I
22.308	30°	8	60	18	0,8	P 2,0	35	I
22.310	30°	10	60	24	1,0	P 2,0	50	I
22.312	30°	12	60	24	1,5	P 2,0	40	I
22.316	30°	16	60	30	2,0	P 5,0	45	I
22.320	30°	20	60	35	2,5	P 5,0	50	I
22.325	30°	25	65	45	3,0	P 8,0	50	I

- 415 mm
- 835 mm
- 835 mm

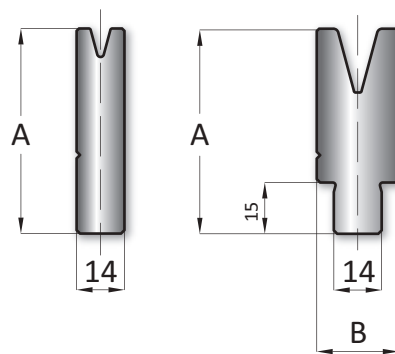
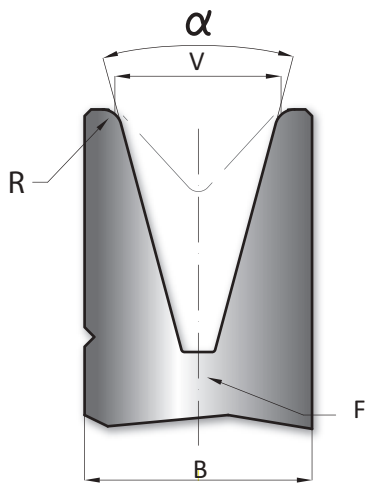

Legende - Legend	Technik - technique
F = Nutgrund - ground of the groove	
R = radius	
P = flach - flat	

88°
30°

	H	Mt
22.002	75,00	I

415 mm

835 mm

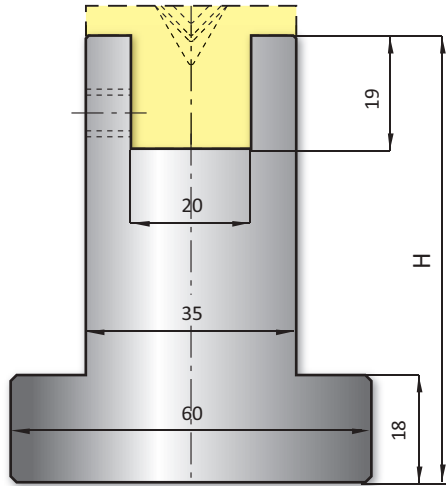

Weitere Möglichkeiten für abdruckfreies Kanten (ab S. 177)

	V	α
32.306	6	30°
32.308	8	30°
32.310	10	30°
32.406	6	45°
32.408	8	45°
32.410	10	45°
32.412	12	45°
32.606	6	60°
32.608	8	60°

	V	α
32.610	10	60°
32.612	12	60°
32.616	16	60°
32.806	6	88°
32.808	8	88°
32.810	10	88°
32.812	12	88°
32.816	16	88°

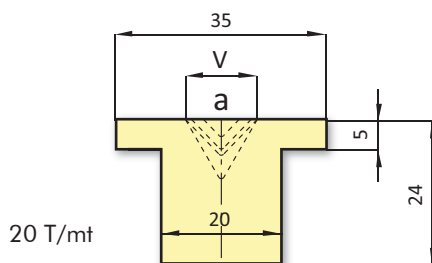

415 mm

835 mm

Orange Line

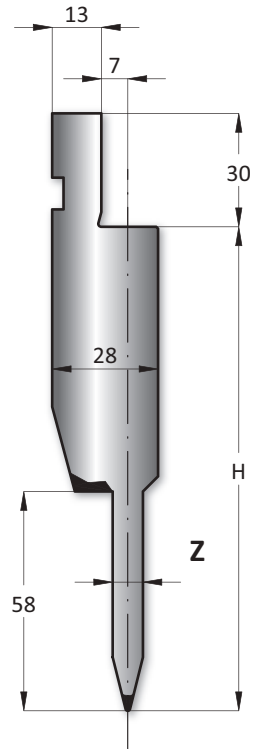

	α	R	H	Z	T/mt	Mt
11.550	24°	0.60	128.00	8	80	II
11.554	24°	0.60	128.00	10	80	II
11.560	24°	0.60	128.00	12	80	II

- 415 mm
- 835 mm
- 835 mm

24°

	R	H	Z	T/mt	Mt
20.550	1.00	80.00	8,2	50	II
20.554	1.00	80.00	10,2	50	II
20.560	1.00	80.00	12,2	50	II

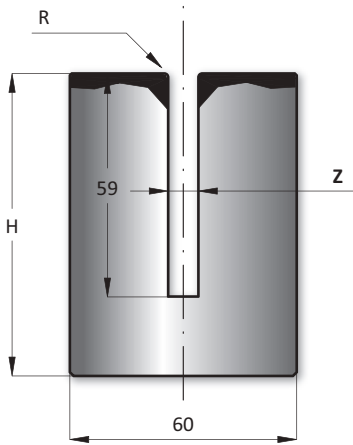

- 415 mm
- 835 mm
- 835 mm



1.01.274

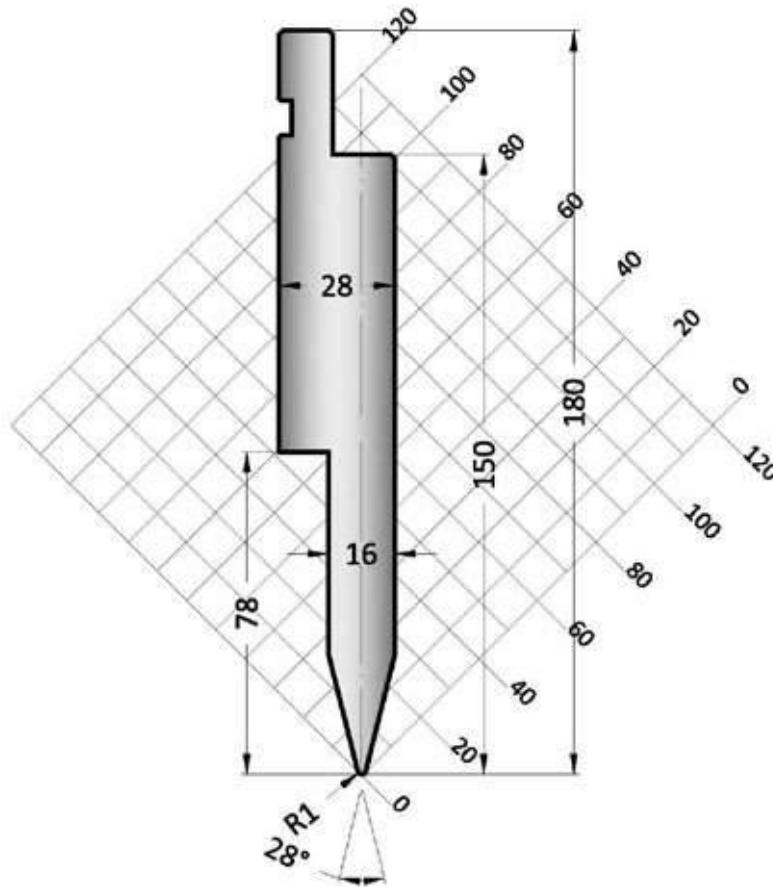

2.14.335

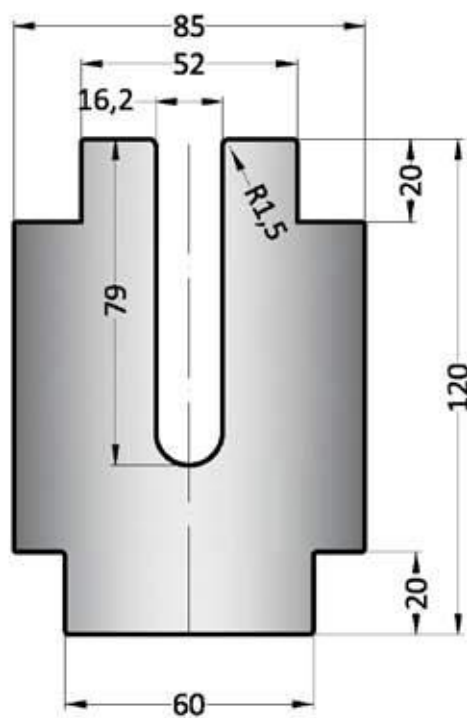

1.01.275 

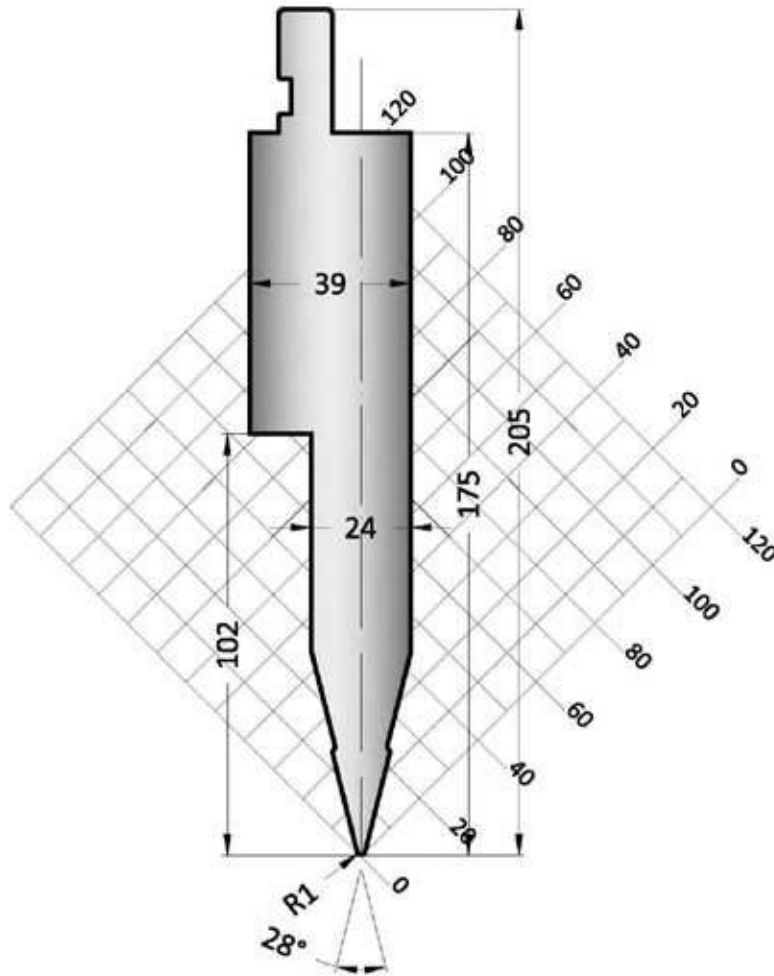

2.14.336 

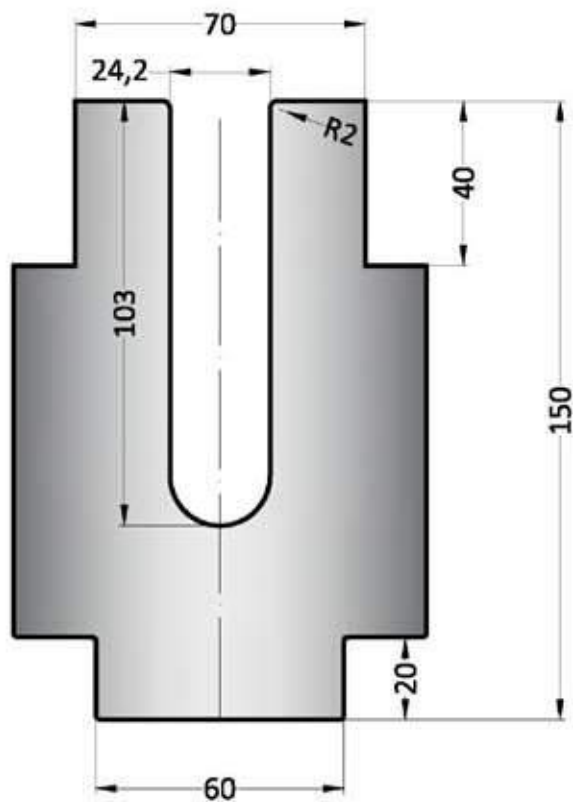

Presskrafttabelle für Umfalzarbeiten - Bending Scheme

S (mm)	(t/m)	T (mm)	(t/m)	2S (mm)
0,6	9	3	23	1,2
0,8	12	3	32	1,6
1,0	15	3,5	40	2,0
1,25	17	3,5	50	2,5
1,5	22	4,6	63	3,0
2,0	30	5,5	80	4,0
2,5	55	6,5	90	5,0
3,0	70	8,0	100	6,0

Material: R = 400 N/mm² (St)

S (mm)	(t/m)	T (mm)	(t/m)	2S (mm)
0,6	15	3	35	1,2
0,8	20	3	50	1,6
1,0	25	3,5	60	2,0
1,25	26	3,5	80	2,5
1,5	38	4,6	95	3,0
2,0	50	5,5	130	4,0

Material: R = 700 N/mm² (VA)

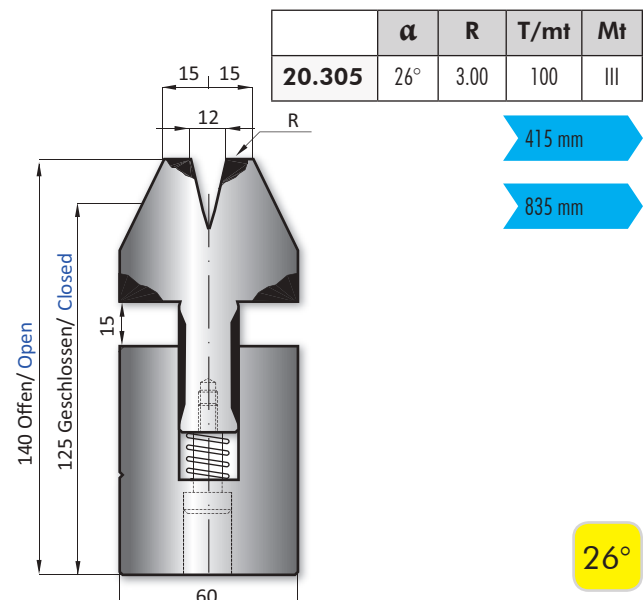
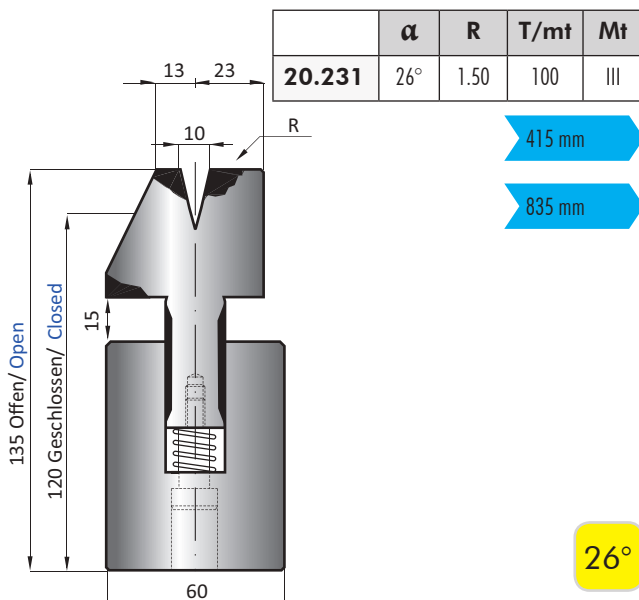
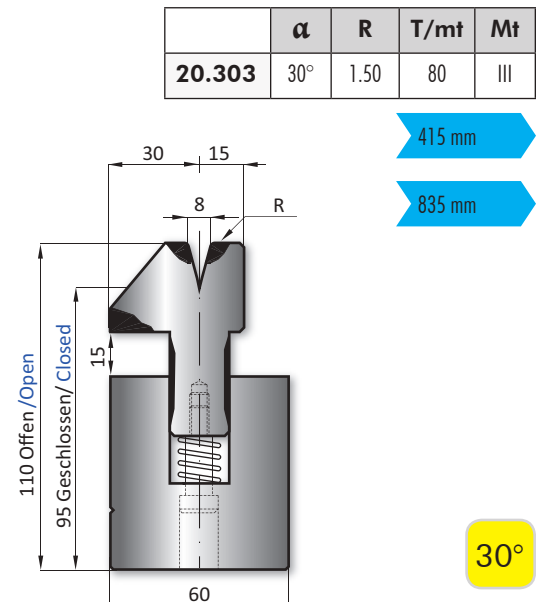
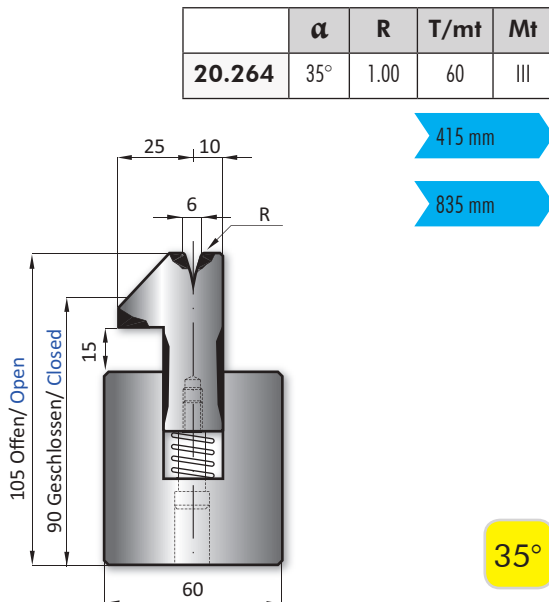
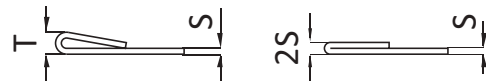

Pneumatische Zudrückmatrize - Pneumatic flattening dies

Vorteile

schnelleres Kanten durch 15 mm weniger Hub
präzisere Kantungen
weniger Verschleiß
an vorhandenen freien Steuerungsausgang 1/0 anschließbar

Advantages

saving 15 mm light and stroke with reduction of working time
more precise bending
less wear
could be connected to existing free control output 1/0

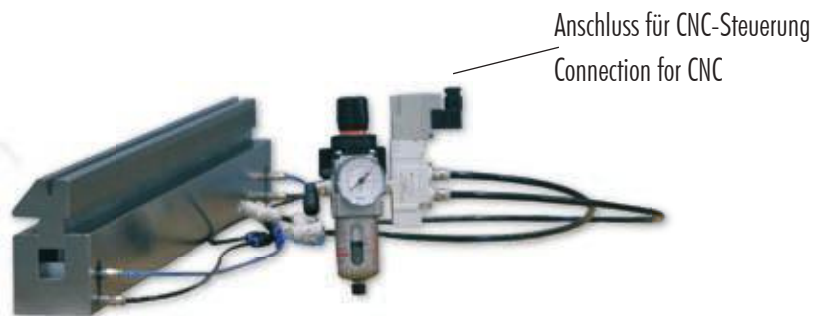

Zubehörsatz für pneumatische Zudrückmatrizen bestehend aus Druckreduzierventil und 12/24 V Elektromagnetventil

The pneumatic kit has to be connected to CNC press brake

	α	R	T/mt	Mt
20.264 P	35°	1.00	60	III

415 mm

835 mm

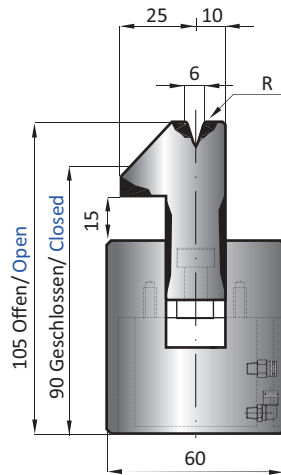

35°

	α	R	T/mt	Mt
20.303 P	30°	1.50	80	III

415 mm

835 mm

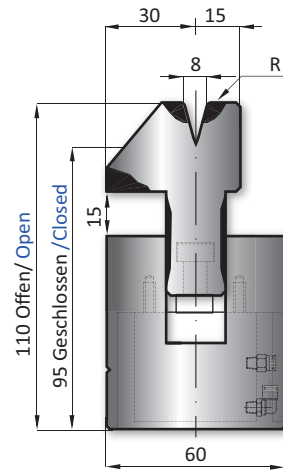

30°

	α	R	T/mt	Mt
20.231 P	26°	1.50	100	III

415 mm

835 mm

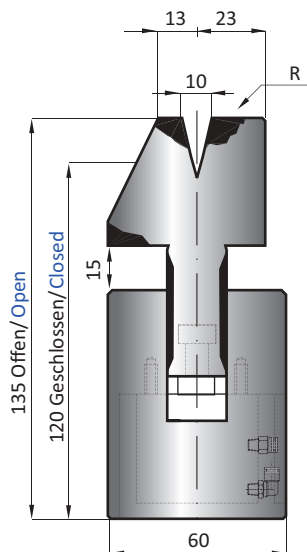

26°

	α	R	T/mt	Mt
20.305 P	26°	3.00	100	III

415 mm

835 mm

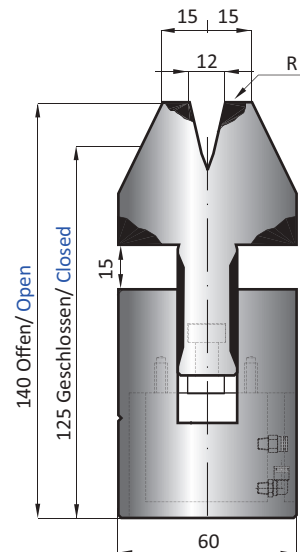

26°

Pneumatisches Zudrückwerkzeug für Wila/Trumpf und Beyeler - Pneumatic flattening tool for Wila/Trumpf and Beyeler dies

	T/mt	Mt
21.600	100	III



500 mm

1000 mm

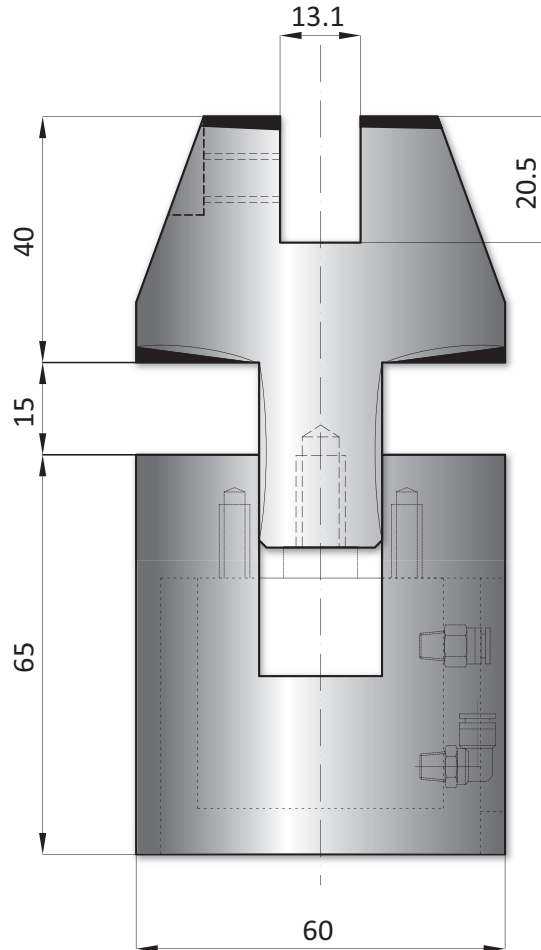

Montagebeispiel - Assembly Scheme

Nur Matrizen mit 30° 20 x 13
Only dies at 30° 20 x 13

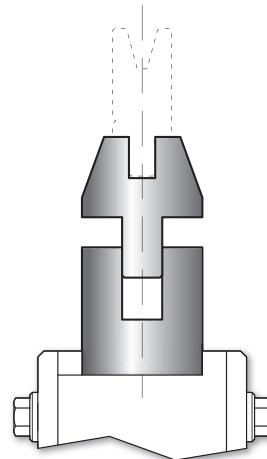
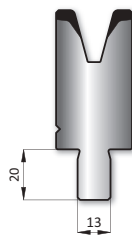

30°

Oberwerkzeuge / Upper tools

direkt einsetzbar auf Abkantpressen von / directly able to work on bending presses of:
Trumpf, Bystronic - Hämmerle, LVD, oder für Abkantpressen mit Klemmsystem NSCL (New Standard Clamping)

Green Line



Green Line

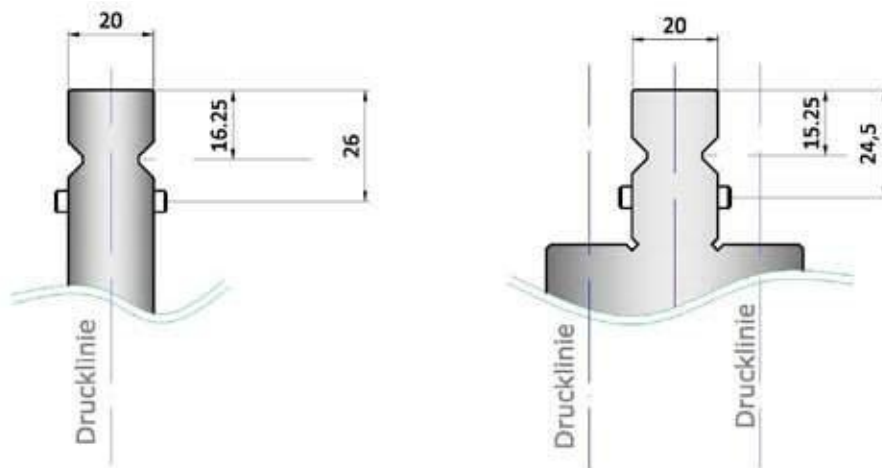

Der **Simple Clamp** ermöglicht den vertikalen Werkzeugwechsel / the **simple clamp** enables the horizontal change of the tool

direkt einsetzbar auf Abkantpressen von: Trumpf, Bystronic - Hämmerle, LVD, oder für Abkantpressen mit Klemmsystem NSCL (New Standard Clamping)

directly able to work on bending presses of: Trumpf, Bystronic - Hämmerle, LVD, or for bending presses with NSCL (New Standard Clamping)

Material:

Westermann24 nutzt die vielfältigen Möglichkeiten der Werkstoffkunde, um Ihnen bestmögliche Qualität zu garantieren.

material:

Westermann24 uses the many possibilities of the material engineering, to guarantee best quality.

Verwendete Werkstoffe sind:

- I: C45
- II: C45, vergütet auf 800-850N/mm²
- III: 42CrMo4, vergütet auf 950-1050N/mm²
- Werkzeuge auf Anfrage: 1.2312, vergütet auf 1000-1200N/mm²

used materials are:

- I: C45
- II: C45, tempered to 800-850N/mm²
- III: 42CrMo4, tempered to 950-1050N/mm²
- tools on request: 1.2312, tempered to 1000-1200N/mm²

Ausführung:

Alle Biegeradien sind geschliffen und gehärtet

design:

All radii are grinded and hardened

Werkzeiglängen:

Die Werkzeiglängen sind bei den Artikelnummern angegeben. Artikelnummern ohne Längenangabe sind auf Anfrage.

length of the tool:

The tool length are posted with the art-no. Article- number without length- determination are available on request.

sektionierte Werkzeugsätze:

Oberwerkzeuge:
OW 550mm sektioniert in : 25,25,30,35,40,45,50,100, 100 Horn links, 100 Horn rechts

tool sets divided into sections:

Upper tool:
OW 550mm sectioned in : 25,25,30,35,40,45,50,100, 100 horn left, 100 horn right

Belastbarkeit:

Die Belastbarkeit der Werkzeuge ist bei den Artikelnummern angegeben. Werkzeuge die höher belastet werden sollen, können auf Anfrage konstruiert werden. (siehe Seite 161)

loading capacity:

The loading capacity of the tools is specified by the article number. Tools which will also be loaded more heavily, can be designed by agreement with the relevant application engineering. (see Page 161)

	α	R	H	T/mt	Mt
15.330	86°	1.00	120.00	80	III
15.330 X	Simple Clamp (außer/not 500)				

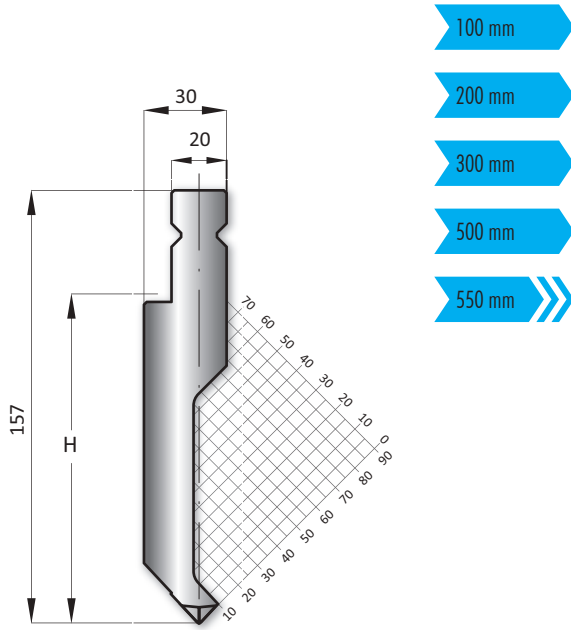

86°

	α	R	H	T/mt	Mt
15.710	86°	1.00	220.00	80	III
15.710 X	Simple Clamp (außer/not 300 u. 500)				

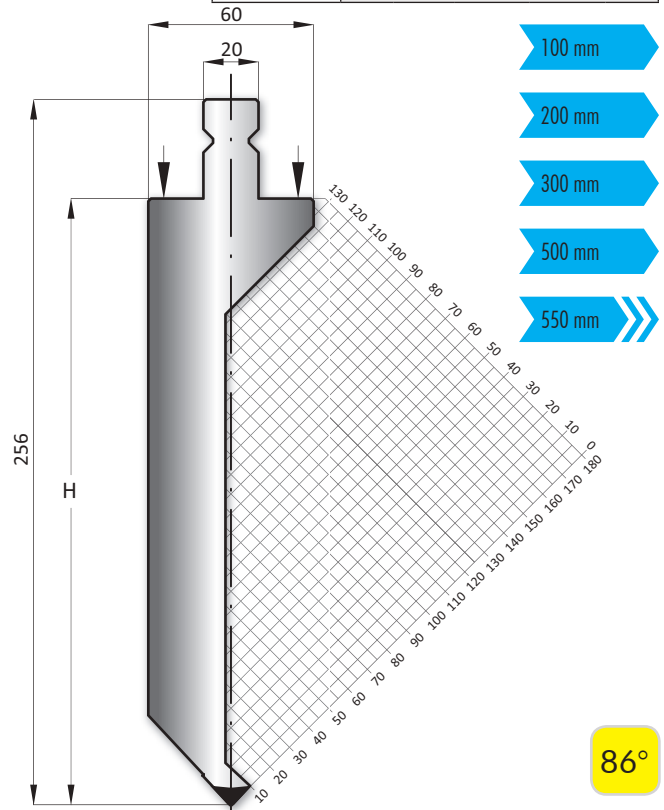

86°

	α	R	H	T/mt	Mt
15.370	86°	1.00	120.00	80	III
15.370 X	Simple Clamp (außer/not 500)				

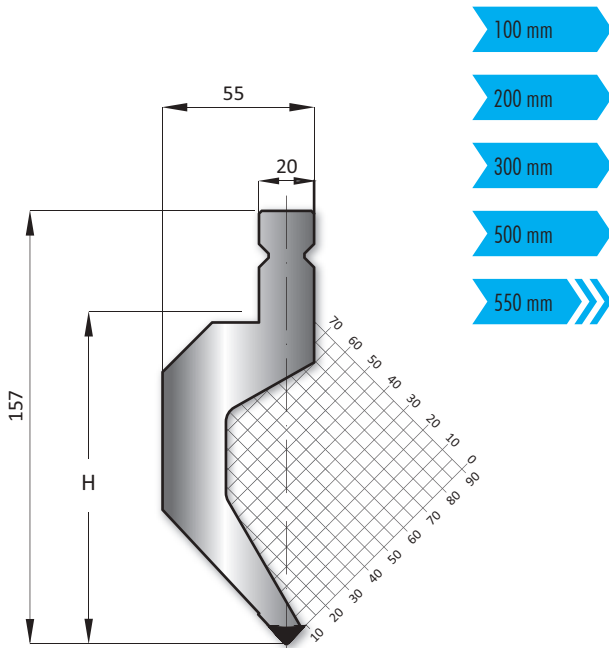

86°

	α	R	H	T/mt	Mt
15.700	86°	1.00	220.00	80	III
15.700 X	Simple Clamp (außer/not 200, 300 u. 500)				

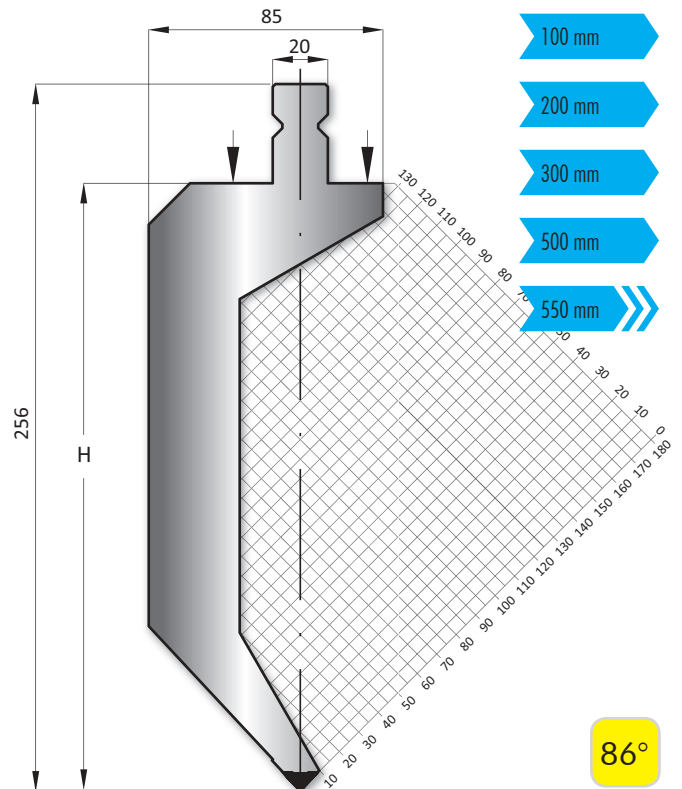

86°

Green Line

- 100 mm
- 200 mm
- 300 mm
- 500 mm
- 550 mm

	α	R	H	T/mt	Mt
15.310	60°	4.00	120.00	130	III
15.310 X	Simple Clamp				

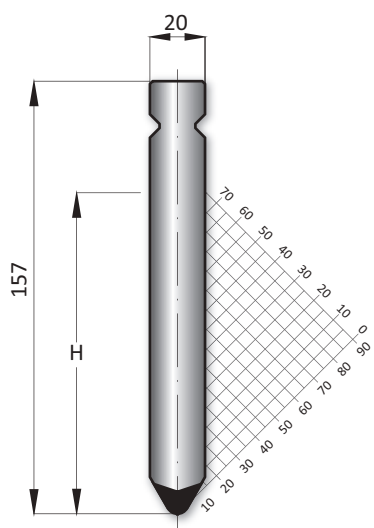

60°

	α	R	H	T/mt	Mt
15.730	60°	4.00	220.00	130	III
15.730 X	Simple Clamp (außer/not 300 u. 500)				

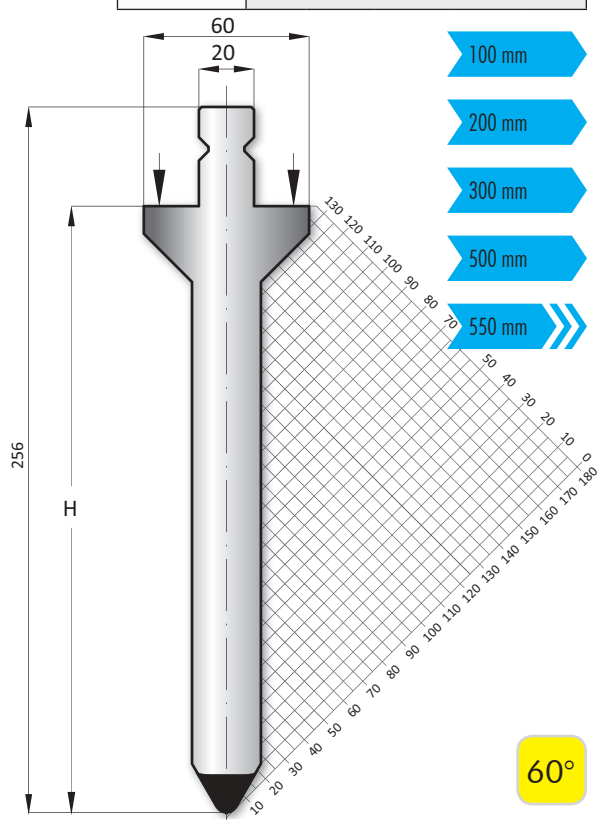

- 100 mm
- 200 mm
- 300 mm
- 500 mm
- 550 mm

60°

- 100 mm
- 200 mm
- 300 mm
- 500 mm
- 550 mm

	α	R	H	T/mt	Mt
15.320	28°	1.00	120.00	80	III
15.320 X	Simple Clamp				

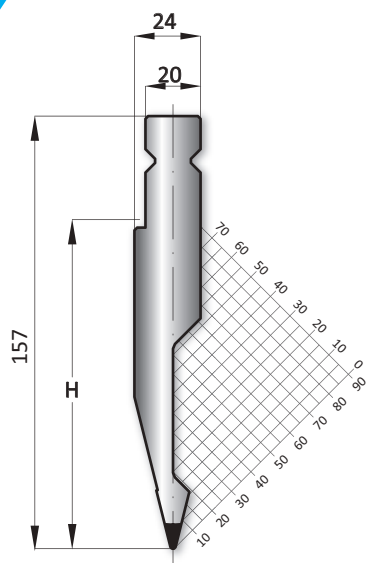

28°

	α	R	H	T/mt	Mt
15.720	28°	1.00	220.00	80	III
15.720 X	Simple Clamp (außer/not 300 u. 500)				

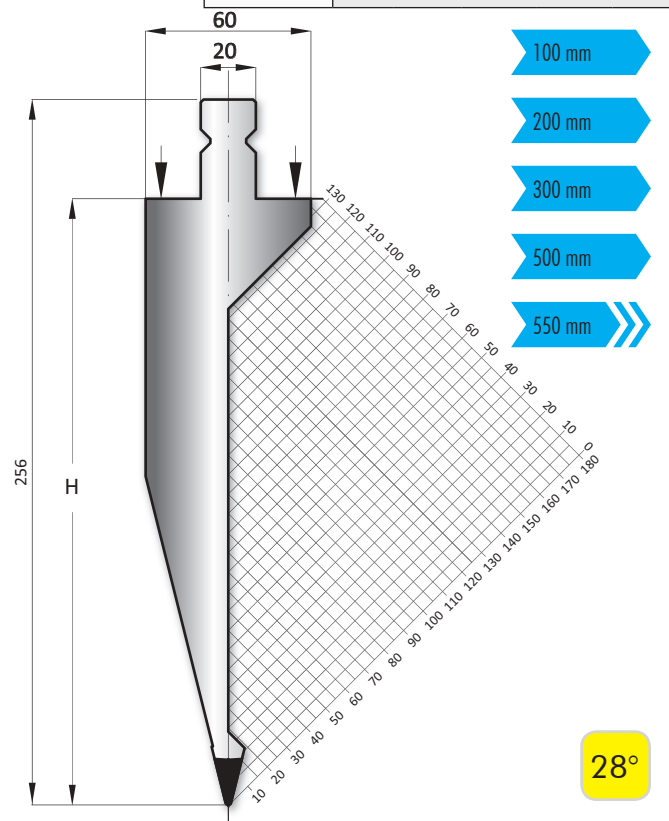

- 100 mm
- 200 mm
- 300 mm
- 500 mm
- 550 mm

28°

- 100 mm
- 200 mm
- 300 mm
- 500 mm
- 550 mm

	α	R	H	T/mt	Mt
15.450	28°	1.00	140.00	40	III
15.450 X	Simple Clamp (außer/not 500)				

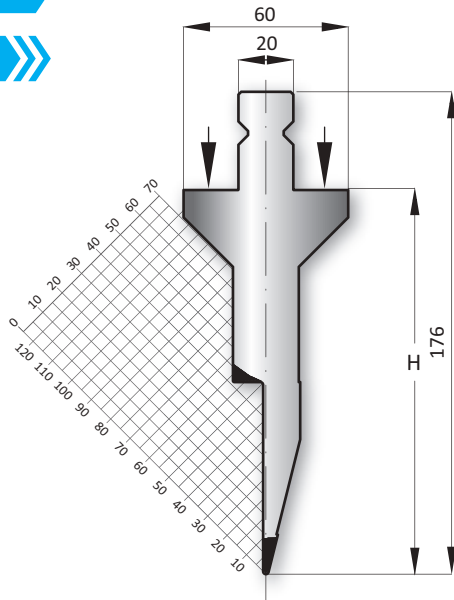

28°

- 100 mm
- 200 mm
- 300 mm
- 500 mm
- 550 mm

	α	R	H	T/mt	Mt
15.750	28°	1.00	240.00	40	III
15.750 X	Simple Clamp (außer/not 300 u. 500)				

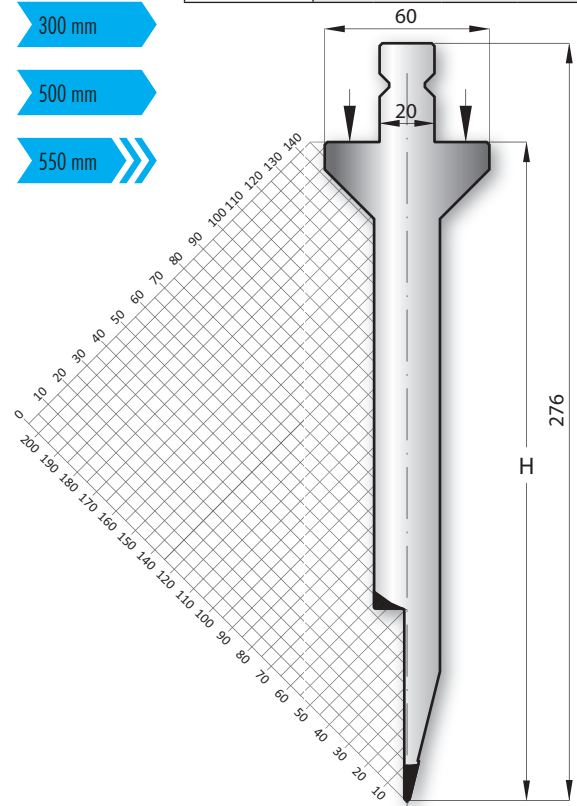

28°

- 100 mm
- 200 mm
- 300 mm
- 500 mm
- 550 mm

	α	R	H	T/mt	Mt
15.670	86°	0.80	158.00	40	III
15.670 X	Simple Clamp (außer/not 500)				

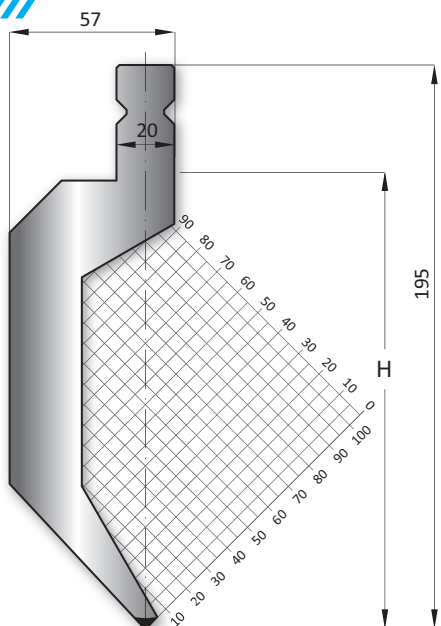

86°

- 100 mm
- 200 mm
- 300 mm
- 500 mm
- 550 mm

	α	R	H	T/mt	Mt
15.635	86°	0.60	158.00	30	III
15.635 X	Simple Clamp (außer/not 500)				

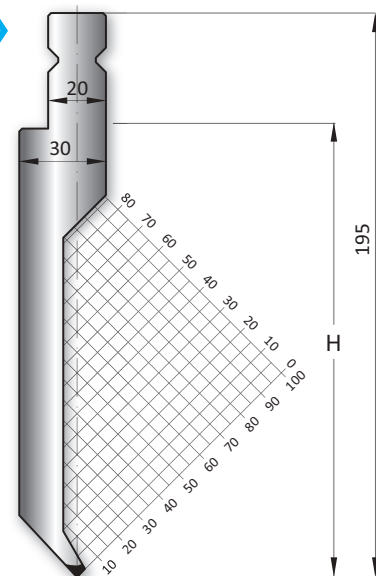

86°

Green Line

	α	R	H	T/mt	Mt
15.630	86°	0.80	158.00	80	III
15.630 X	Simple Clamp (außer/not 500)				

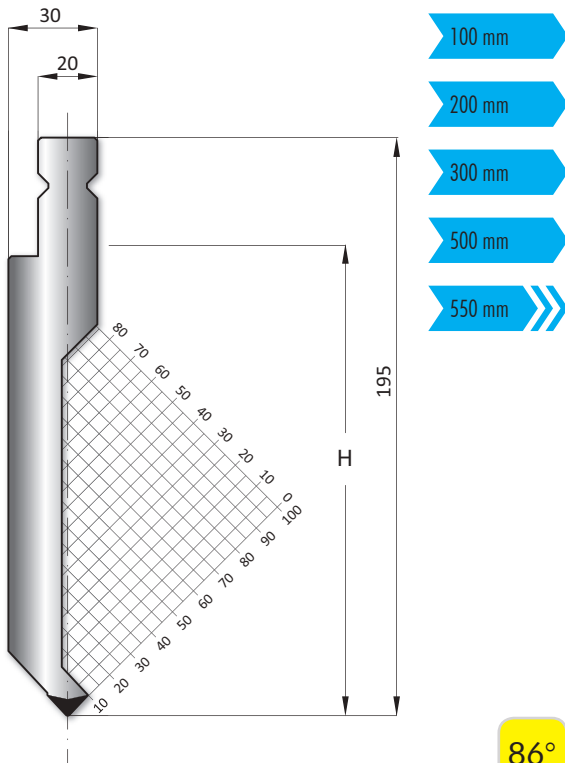

86°

1.08.182



Westermann24 entwickelt für Sie die richtige Werkzeugform für Ihr Produkt. (S. 161)



	α	R	H	T/mt	Mt
15.680	60°	0.80	158.00	40	III
15.680 X	Simple Clamp (außer/not 500)				

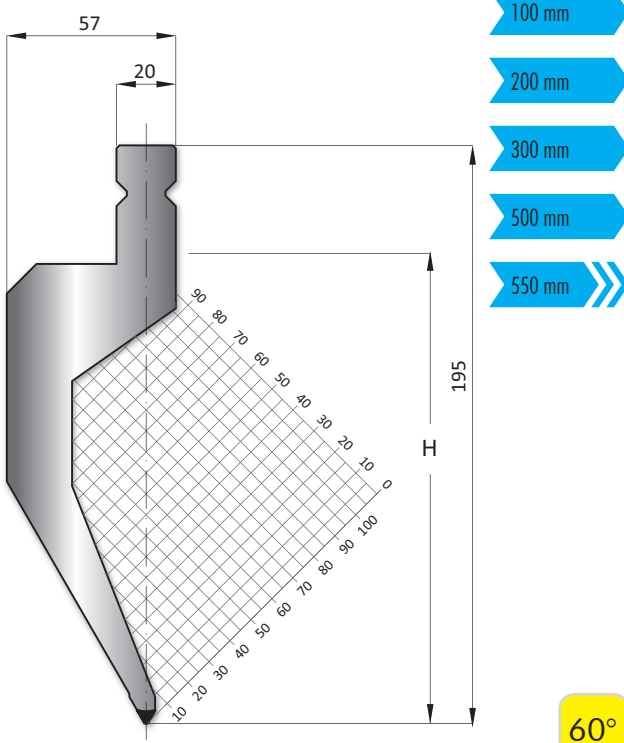

60°

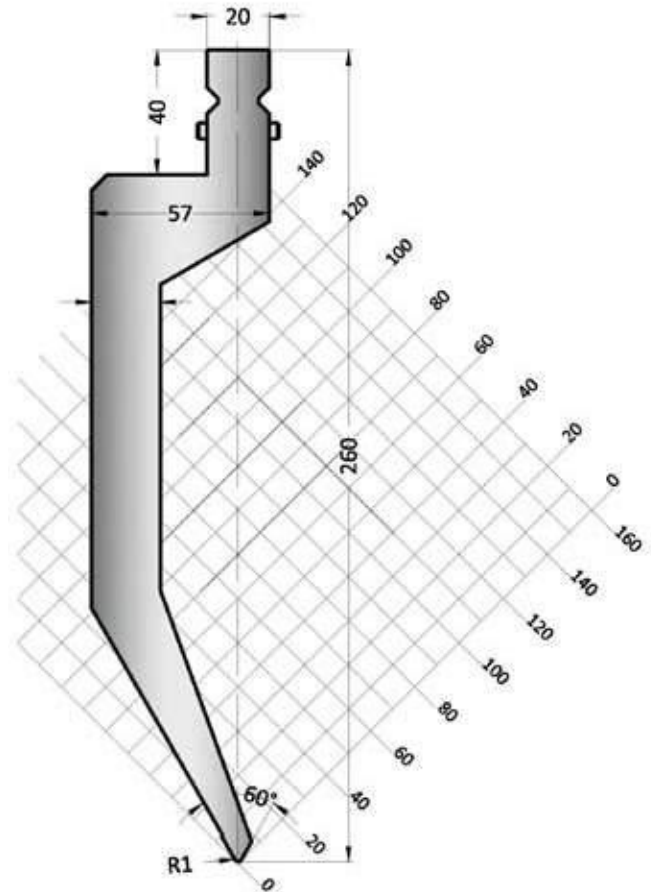

	α	R	H	T/mt	Mt
15.610	28°	3.00	158.00	100	III
15.610 X	Simple Clamp (außer/not 500)				

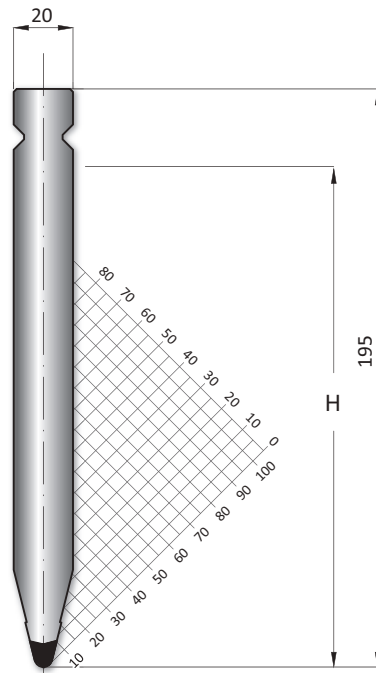

- 100 mm
- 200 mm
- 300 mm
- 500 mm
- 550 mm

28°

Green Line

	α	R	H	T/mt	Mt
15.620	28°	1.00	158.00	80	III
15.620 X	Simple Clamp				

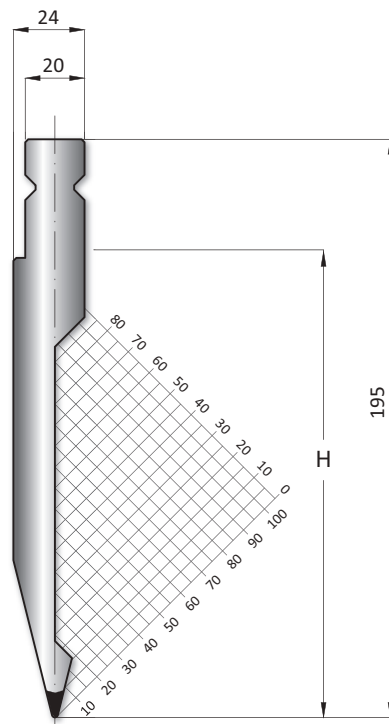

- 100 mm
- 200 mm
- 300 mm
- 500 mm
- 550 mm

28°

- 100 mm
- 200 mm
- 550 mm

	α	R	H	T/mt	Mt
15.790	84°	1.00	220.00	60	III

Green Line

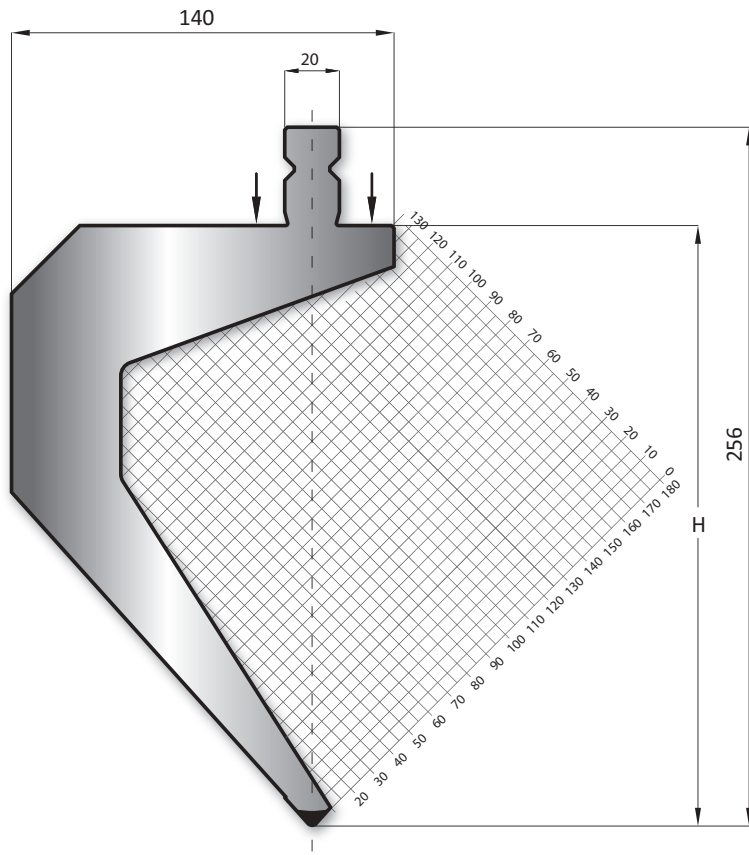

84°

100 mm

200 mm

550 mm

	α	R	H	T/mt	Mt
15.800	86°	1.00	300.00	40	III
15.800 X	Simple Clamp (außer/not 200)				

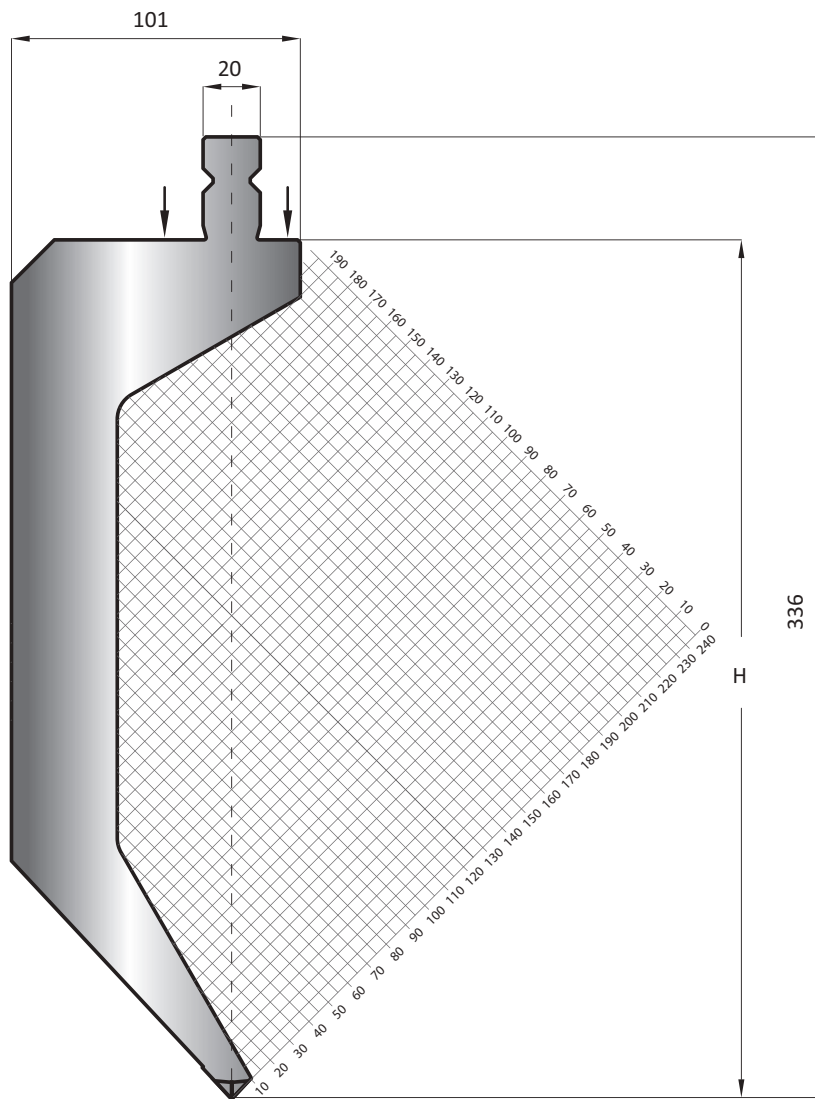

86°

Green Line

	H	Mt
15.760	120.00	III
15.760 X	Simple Clamp (außer/not 500)	

- 100 mm
- 200 mm
- 300 mm
- 500 mm
- 550 mm

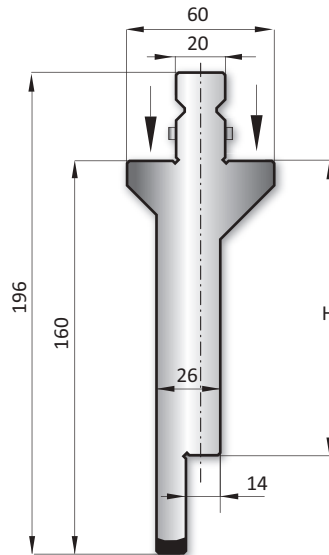

- 100 mm
- 500 mm
- 550 mm

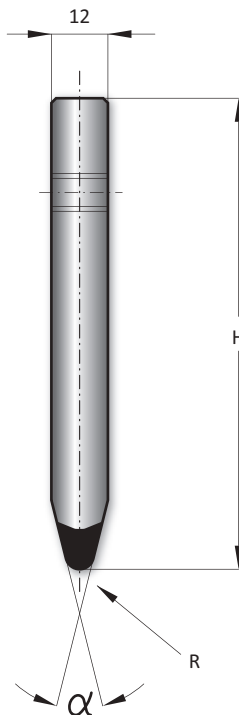

	α	R	H	T/mt	Mt
15.776	86°	1.00	100	100	III
15.774	84°	1.00	100	100	III
15.769	28°	6.00	100	100	III
15.768	28°	5.00	100	100	III
15.767	28°	4.00	100	100	III
15.766	28°	3.00	100	100	III
15.765	28°	2.00	100	100	III
15.763	28°	1.00	100	100	III
15.761	28°	0.50	100	100	III

- 86°
- 84°
- 28°

	H1	H2	T/mt	Mt
15.050	62	64	100	I

415 mm

835 mm

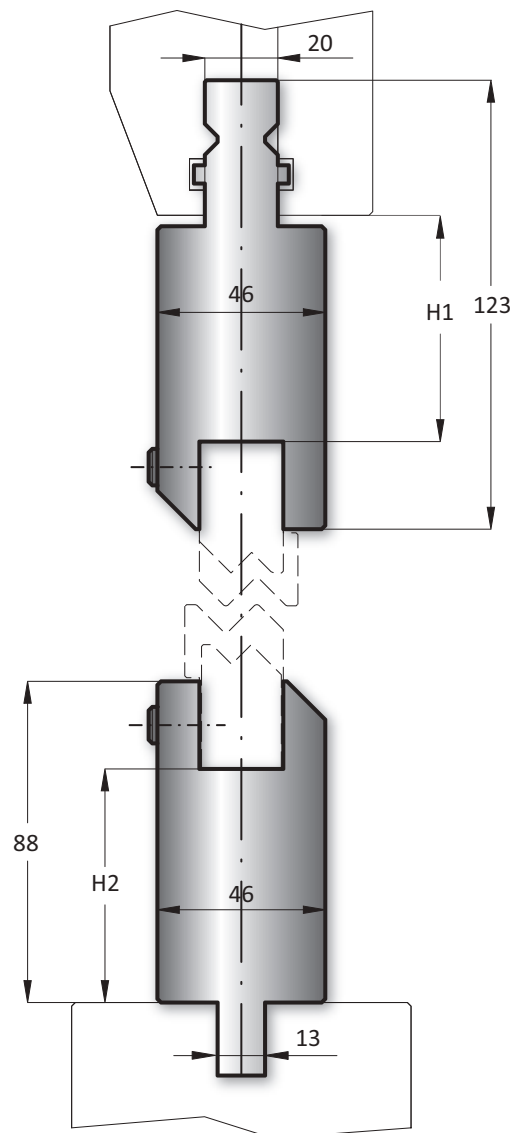

Montagebeispiel - Assembly Scheme

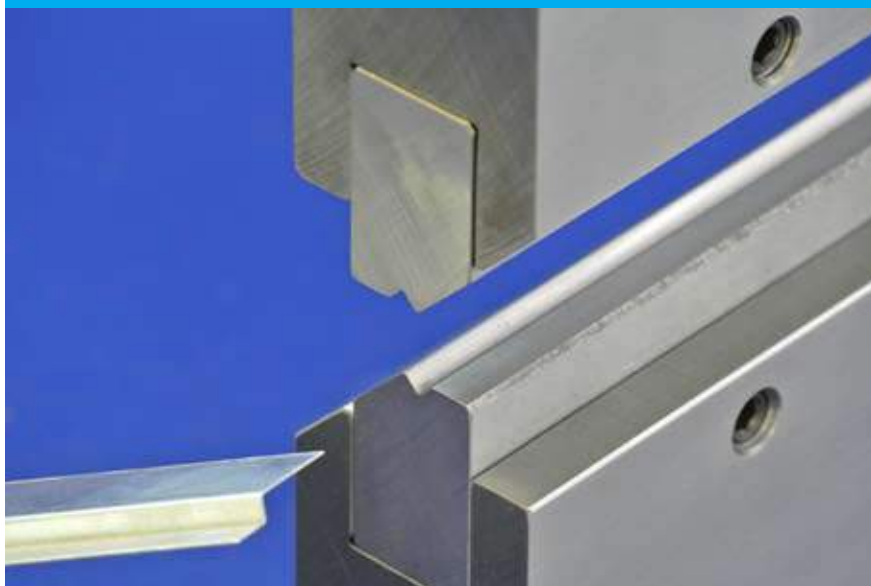

415 mm
835 mm

	Z	α	T/mt	Mt
40.510	1.00	160°	100	I
40.515	1.50	160°	100	I
40.520	2.00	150°	100	I
40.525	2.50	140°	100	I

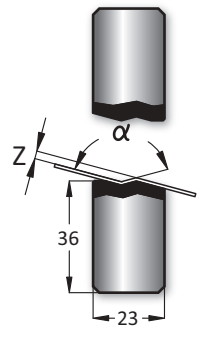

160°
150°
140°

415 mm
835 mm

	Z	α	T/mt	Mt
40.511	1.00	90°	100	I
40.516	1.50	90°	100	I
40.521	2.00	90°	100	I
40.526	2.50	90°	100	I
40.530	3.00	90°	100	I
40.535	3.50	90°	100	I
40.540	4.00	90°	100	I
40.545	4.50	90°	100	I
40.550	5.00	90°	100	I
40.555	5.50	90°	100	I
40.560	6.00	90°	100	I
40.565	6.50	90°	100	I
40.570	7.00	90°	100	I
40.575	7.50	90°	100	I
40.580	8.00	90°	100	I

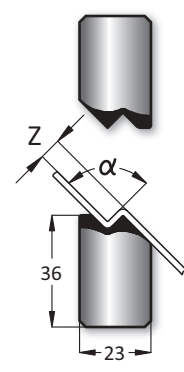

90°

415 mm
835 mm

	Z	α	T/mt	Mt
40.590	9.00	90°	100	I
40.610	10.00	90°	100	I
40.611	11.00	90°	100	I
40.612	12.00	90°	100	I

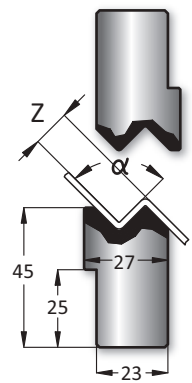

90°

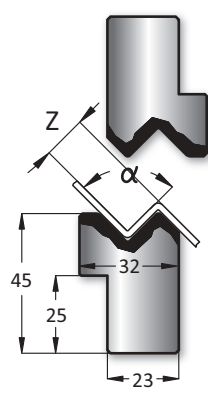

	Z	α	T/mt	Mt
40.613	13.00	90°	100	I
40.614	14.00	90°	100	I
40.615	15.00	90°	100	I

415 mm
835 mm

90°

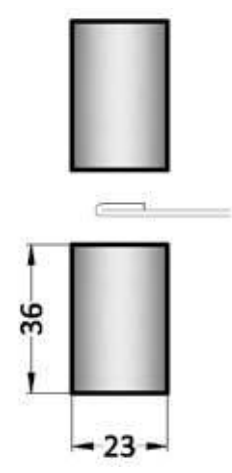

	Z	α	T/mt	Mt
40.500				I

415 mm
835 mm

90°

	H	T/mt	Mt
15.010	103.00	80	I
15.010 X	Simple Clamp (außer/not 830)		

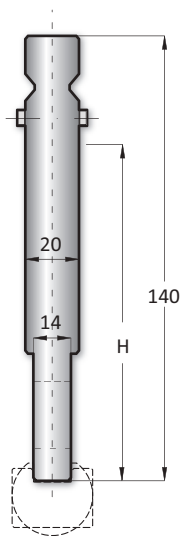
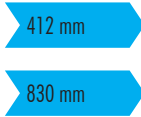

	H	T/mt	Mt
15.014	160.00	80	I

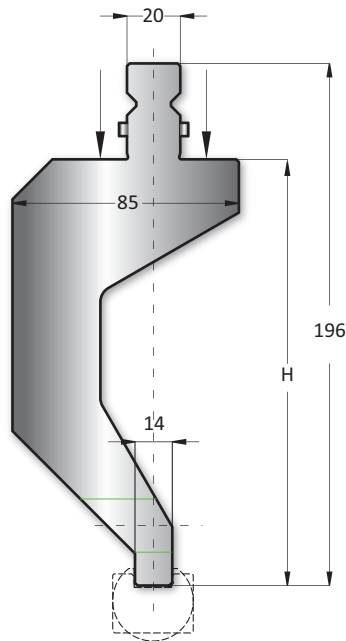
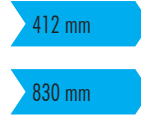

	H	T/mt	Mt
15.018	220.00	80	I

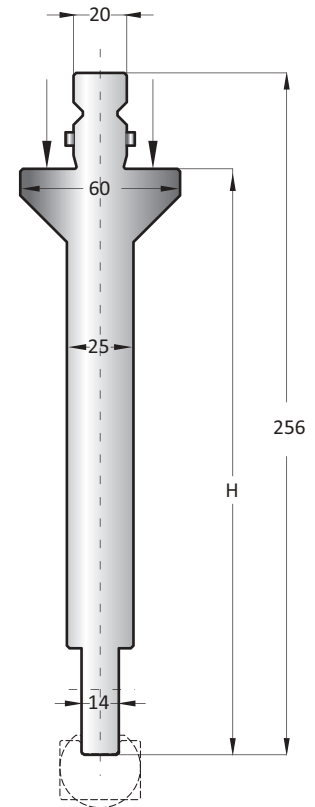
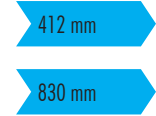

415 mm

835 mm

	R	A
10.300	7.00	11.50
10.301	7.50	11.50
10.302	8.00	13.00
10.303	9.00	16.00
10.304	10.00	16.00
10.305	11.00	16.00
10.306	11.50	19.00
10.307	12.00	20.00

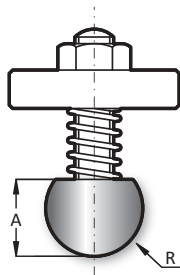

415 mm

835 mm

	R	A	B
10.308	12.50	16.00	21.00
10.309	13.00	17.00	23.00
10.310	14.00	19.00	25.00
10.311	15.00	20.00	27.00
10.312	16.00	21.00	28.00
10.313	17.00	21.50	31.50
10.314	17.50	22.00	32.00
10.315	19.00	25.00	32.00
10.316	20.00	24.00	34.00
10.317	22.50	25.00	33.00
10.318	25.00	29.00	39.00
10.319	27.50	34.00	44.00
10.320	30.00	34.00	44.00
10.321	35.00	45.00	55.00
10.322	40.00	45.00	55.00
10.323	45.00	50.00	60.00
10.324	50.00	54.00	64.00

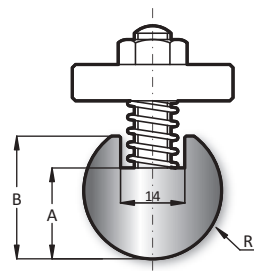

415 mm

835 mm

	A	B
10.325	17.00	22.00

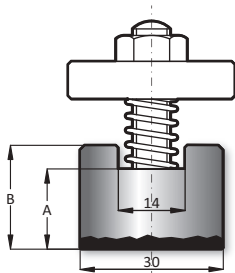

Westermann24 liefert
Ihnen Lösungen für
Halter mit Einsatz.
(S. 163)

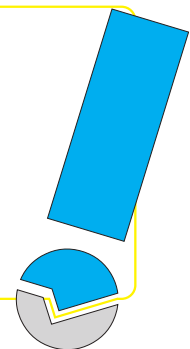

Unterwerkzeuge / Lower tools

direkt einsetzbar auf Abkantpressen von / directly able to work on bending presses of:
Trumpf, Bystronic-Hämmerle oder mit Tischnut für Zapfen 13x20mm

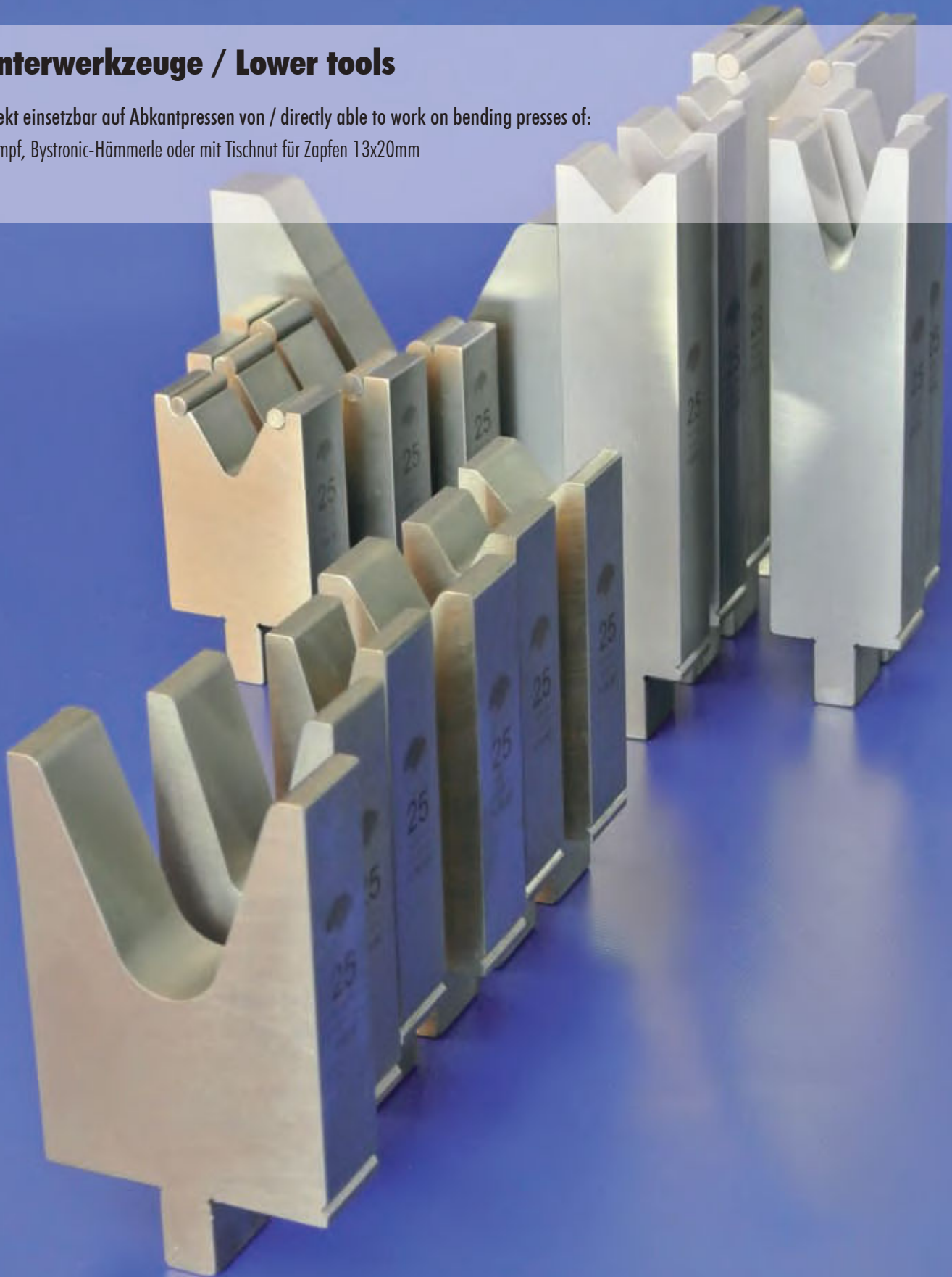

Green Line

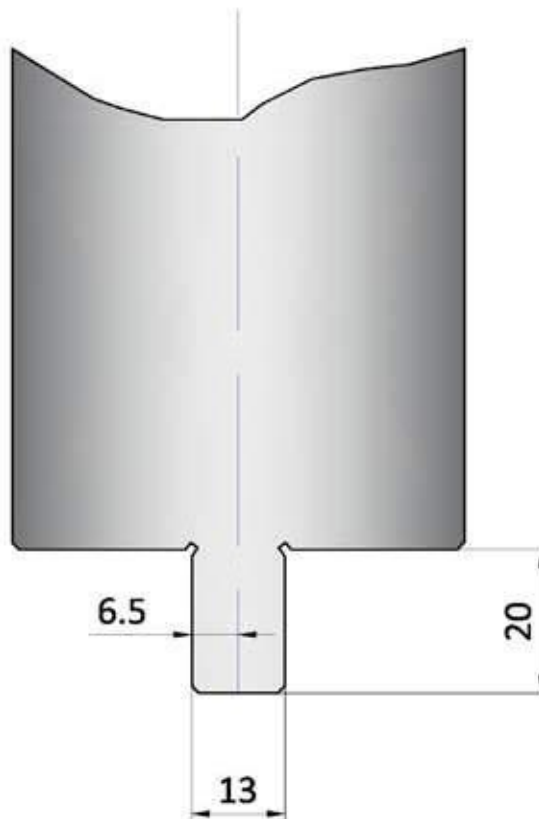

direkt einsetzbar auf Abkantpressen von:
Trumpf, Bystronic-Hämmerle, oder mit Tischnut
für Zapfen 13x20mm

directly able to work on bending presses of:
Trumpf, Bystronic-Hämmerle, or with table
anchoring slots for pivots 13x20mm

Material:

Westermann24 nutzt die vielfältigen Möglichkeiten der Werkstoffkunde, um Ihnen bestmögliche Qualität zu garantieren.

Verwendete Werkstoffe sind:

- I: C45
- II: C45, vergütet auf 800-850N/mm²
- III: 42CrMo4, vergütet auf 950-1050N/mm²
- Werkzeuge auf Anfrage: 1.2312, vergütet auf 1000-1200N/mm²

Ausführung:

Alle Biegeradien sind geschliffen und gehärtet

Werkzeuglängen:

Die Werkzeuglängen sind bei den Artikelnummern angegeben.
Artikelnummern ohne Längenangabe sind auf Anfrage.

sektionierte Werkzeugsätze:

Unterwerkzeuge:
UW 550mm sektioniert in: 25,25,30,35,40,45,50,100,200

Belastbarkeit:

Die Belastbarkeit der Werkzeuge ist bei den Artikelnummern angegeben.
Werkzeuge die höher belastet werden sollen, können auf Anfrage konstruiert werden.
(siehe Seite 161)

material:

Westermann24 uses the many possibilities of the material engineering, to guarantee best quality.

used materials are:

- I: C45
- II: C45, tempered to 800-850N/mm²
- III: 42CrMo4, tempered to 950-1050N/mm²
- tools on request: 1.2312, tempered to 1000-1200N/mm²

design:

All radii are grinded and hardened

length of the tool:

The tool length are posted with the art-no.
Article- number without length- determination are available on request.

tool sets divided into sections:

Lower tool:
UW 550mm sectioned in: 25,25,30,35,40,45,50,100,200

loading capacity:

The loading capacity of the tools is specified by the article number.
Tools which will also be loaded more heavily, can be designed by agreement with the relevant application engineering. (see Page 161)

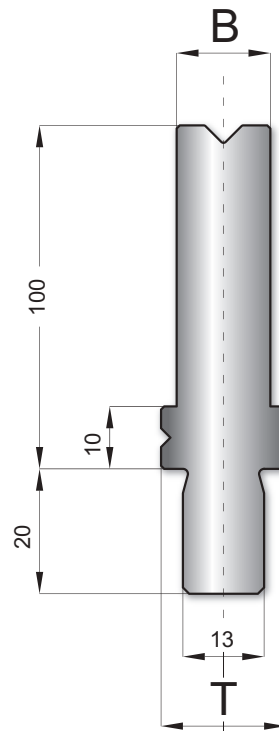
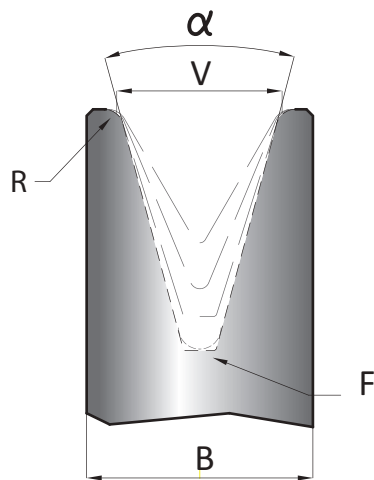

H = 100

H = 120

100 mm

500 mm

550 mm

Green Line

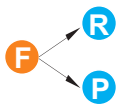

86°	V	R	H	B	T	F	T/mt	Mt
25.100	4	0,6	100	8	20	R 0,6	100	I
25.101	6	0,6	100	20	20	R 0,6	100	I
25.102	8	0,8	100	20	20	R 0,8	100	I
25.103	10	1,0	100	20	20	R 1,0	100	I
25.104	12	1,0	100	35	25	R 1,0	100	I
25.105	16	1,6	100	30	30	R 1,6	100	I
25.106	20	2,0	100	30	30	R 2,0	100	I

84°	V	R	H	B	T	F	T/mt	Mt
25.201	6	0,6	100	20	20	R 0,6	100	I
25.202	8	0,8	100	20	20	R 0,8	100	I
25.203	10	1,0	100	20	20	R 1,0	100	I
25.204	12	1,0	100	25	25	R 1,0	100	I
25.205	16	1,6	100	30	30	R 1,6	100	I
25.206	20	2,0	100	30	30	R 2,0	100	I

80°	V	R	H	B	T	F	T/mt	Mt
25.207	24	2,5	100	35	35	R 2,5	100	I
25.208	30	5,0	100	45	45	R 3,0	100	I
25.209	40	5,0	100	55	55	R 3,0	100	I
25.210	50	5,0	100	65	65	R 5,0	100	I
25.111	60	5,0	100	75	75	R 5,0	100	I
25.112	70	5,0	100	85	85	R 5,0	100	I
25.113	80	5,0	100	100	100	R 5,0	100	I
25.114	90	8,0	120	110	110	R 5,0	100	I
25.115	100	8,0	120	120	120	R 5,0	100	I
2.11.164	120							

60°	V	R	H	B	T	F	T/mt	Mt
2.11.144	16		100					
2.11.145	20		100					
2.11.146	24		100					
2.11.147	30		100					
2.11.148	35		100					
2.11.149	40		100					
2.11.150	50		100					
2.11.151	60		100					
2.11.152	80		100					
2.11.153	100		100					
25.116	120	8,0	120	145	145	P 38	100	I

Legende - Legend	Technik - technique
	F = Nutgrund - ground of the groove
	R = radius
	P = flach - flat

86°

84°

80°

60°

30°	V	R	H	B	T	F	T/mt	Mt
25.400	4	0,6	100	15	20	R 0,6	20	III
25.401	6	0,6	100	20	20	R 0,6	40	III
25.421	6	3,0	100	20	20	R 0,6	40	III
25.402	8	1,0	100	20	20	R 1,0	40	III
25.422	8	3,0	100	20	20	R 1,0	40	III
25.403	10	1,0	100	20	20	R 1,0	40	III
25.423	10	3,0	100	20	20	R 1,0	40	III
25.404	12	1,0	100	25	25	R 1,0	40	III
25.424	12	3,0	100	25	25	R 1,0	40	III
25.405	16	1,6	100	30	30	R 1,6	50	III
25.425	16	3,0	100	30	30	R 1,6	50	III
25.406	20	2,0	100	35	35	R 2,0	60	III
25.407	24	2,5	100	40	40	R 2,5	65	III
25.408	30	3,0	100	55	55	R 3,0	90	III
25.409	40	5,0	100	60	60	R 5,0	90	III
2.22.141	30							
2.11.142	35							
2.11.143	40							



30°

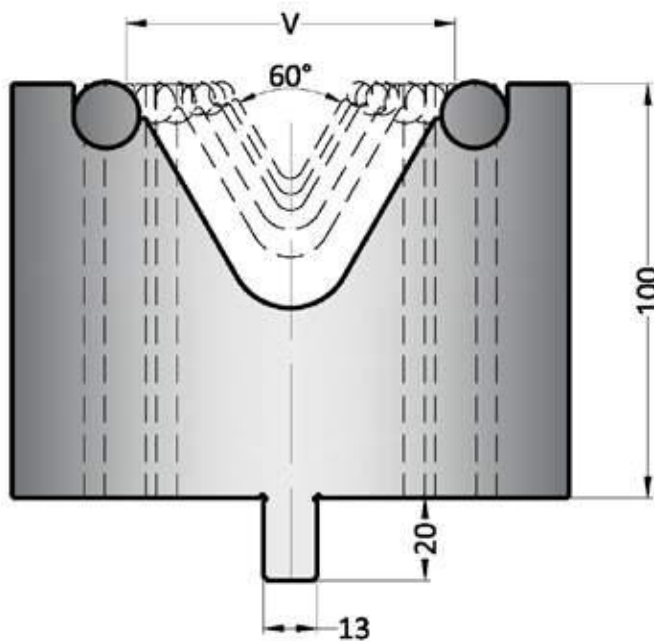

	V	α	H
2.20.011	30	60°	100.00
2.20.012	35	60°	100.00
2.20.013	40	60°	100.00
2.20.014	50	60°	100.00
2.20.015	60	60°	100.00
2.20.016	80	60°	100.00



Westermann-Steckmatrize - mit Einlaufwellen 60°

60°

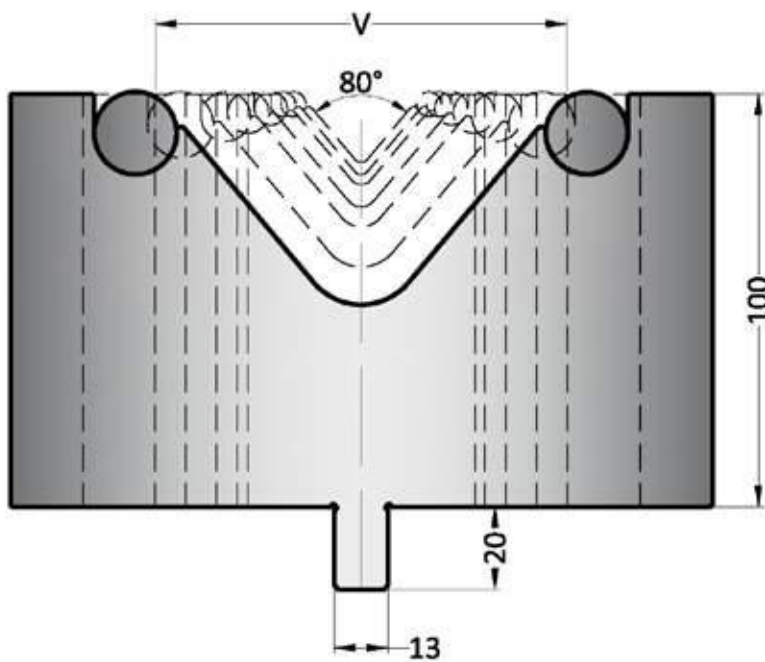

	V	α	H
2.20.017	30	80°	100.00
2.20.018	35	80°	100.00
2.20.019	40	80°	100.00
2.20.020	50	80°	100.00
2.20.021	60	80°	100.00
2.20.022	80	80°	100.00



Westermann 24 liefert
Ihnen Matrizen mit
Welleneinsatz.
(S. 162)

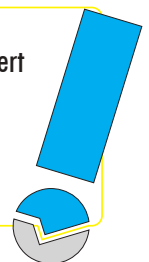

Westermann-Steckmatrize - mit Einlaufwellen 80°

80°

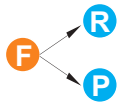

H=150

- 100 mm
- 500 mm
- 550 mm

86°	V	R	B	T	F	T/mt	Mt
25.601	6	0,6	20	20	R 0,6	100	I
25.602	8	0,8	20	20	R 0,8	100	I
25.603	10	1,0	20	20	R 1,0	100	I
25.604	12	1,0	25	25	R 1,0	100	I
25.605	16	1,6	30	30	R 1,6	100	I
25.606	20	2,0	30	30	R 2,0	100	I

84°	V	R	B	T	F	T/mt	Mt
25.621	6	0,6	20	20	R 0,6	100	I
25.622	8	0,8	20	20	R 0,8	100	I
25.623	10	1,0	20	20	R 1,0	100	I
25.624	12	1,0	25	25	R 1,0	100	I
25.625	16	1,6	30	30	R 1,6	100	I
25.626	20	2,0	30	30	R 2,0	100	I

80°	V	R	B	T	F	T/mt	Mt
25.627	24	2,5	35	35	R 2,5	100	I
25.628	30	5,0	45	45	R 3,0	100	I
25.629	40	5,0	55	55	R 3,0	100	I
25.630	50	5,0	65	65	R 5,0	100	I
2.12.182	60						
2.12.183	80						
2.12.184	100						
2.12.185	120						

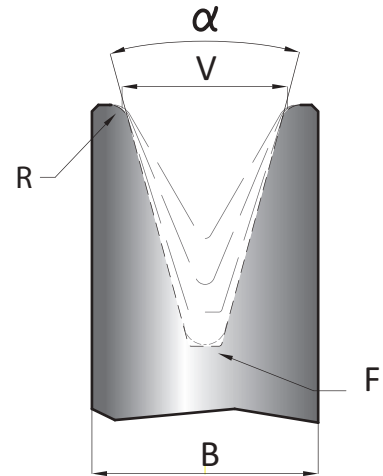
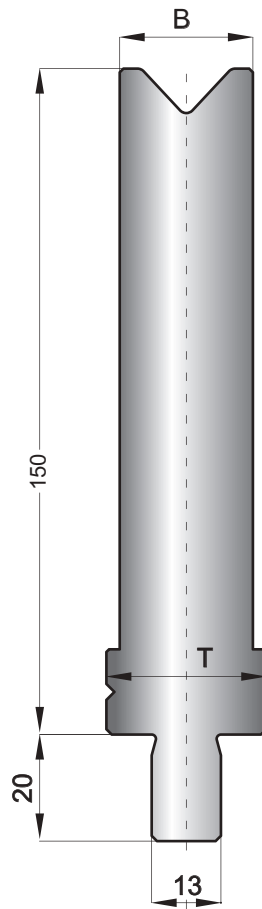

Legende - Legend	Technik - technique
F = Nutgrund - ground of the groove	
R = radius	
P = flach - flat	

60°	V	H
2.12.164	16	150.00
2.12.165	20	150.00
2.12.166	24	150.00
2.12.167	30	150.00
2.12.168	35	150.00
2.12.169	40	150.00
2.12.170	50	150.00
2.12.171	60	150.00
2.12.172	80	150.00
2.12.173	100	150.00
2.12.174	120	150.00

30°	V	R	B	T	F	T/mt	Mt
25.901	6	0,6	20	20	R 0,6	30	III
25.902	8	1,0	20	20	R 1,0	40	III
25.903	10	1,0	20	20	R 1,0	40	III
25.904	12	1,0	25	25	R 1,0	40	III
25.905	16	1,6	30	30	R 1,6	50	III
25.906	20	2,0	35	35	R 2,0	60	III
25.907	24	2,5	40	40	R 2,5	65	III
25.908	30	3,0	55	55	R 3,0	90	III
25.909	40	5,0	60	60	R 5,0	90	III

- 86°
- 84°
- 80°
- 60°
- 30°

Green Line

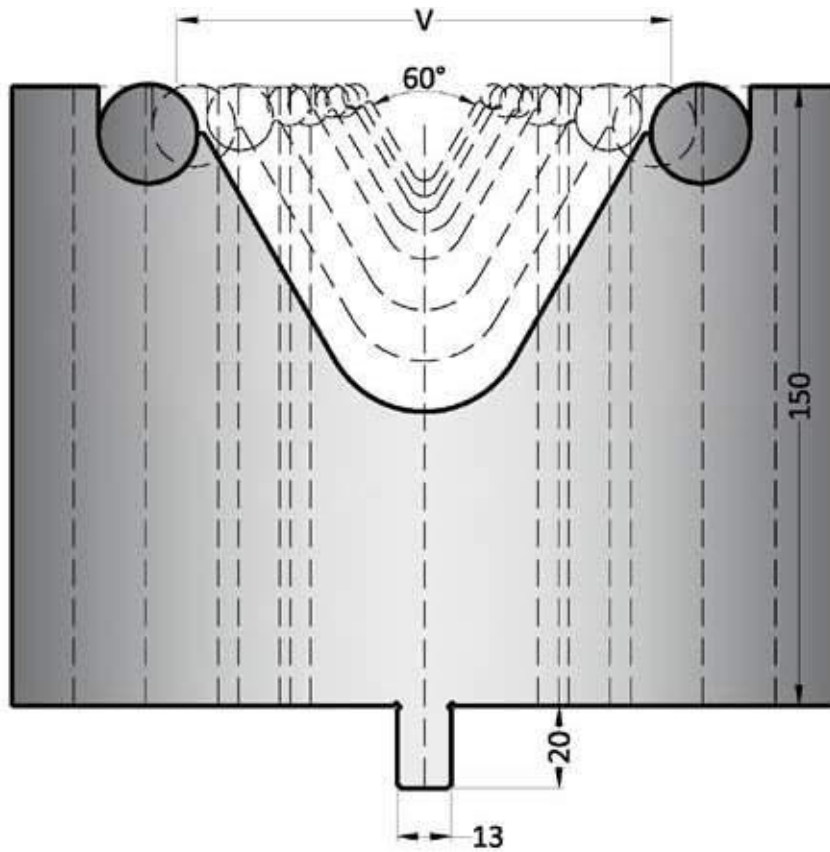

Westermann-Steckmatrize - mit Einlaufwellen 60°

	V	α	H
2.21.004	30	60°	150.00
2.21.005	35	60°	150.00
2.21.006	40	60°	150.00
2.21.007	50	60°	150.00
2.21.008	60	60°	150.00
2.21.009	80	60°	150.00
2.21.010	100	60°	150.00
2.21.011	120	60°	150.00



Westermann 24 liefert
Ihnen Matrizen mit
Welleneinsatz.
(S. 162)

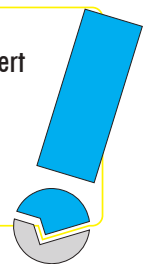

60°

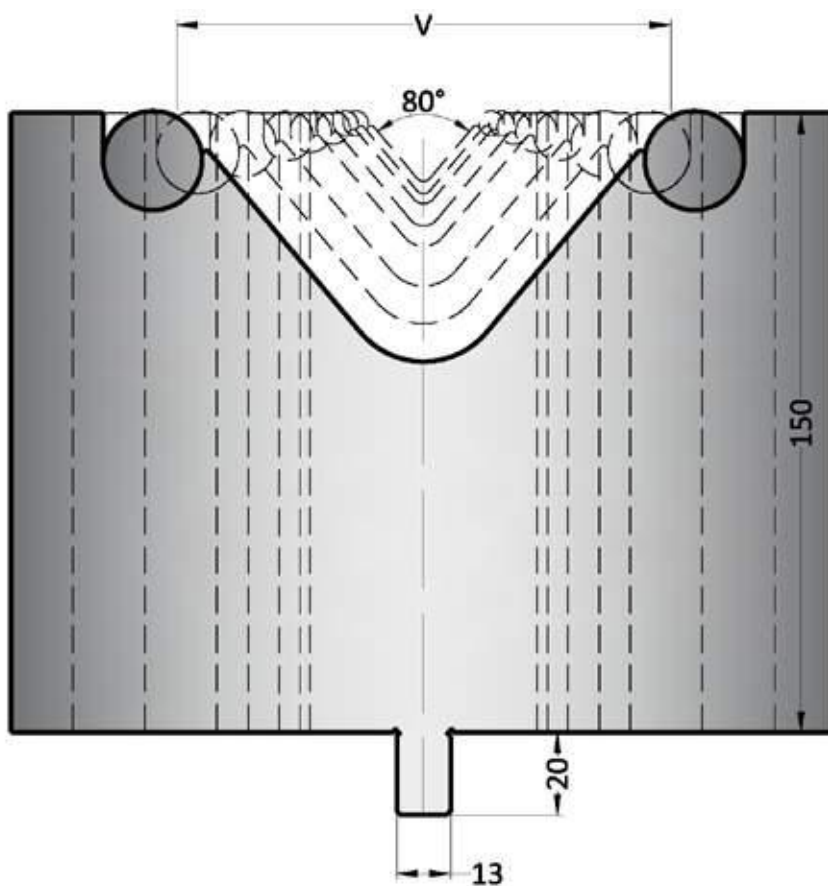

Westermann-Steckmatrize - mit Einlaufwellen 80°

	V	α	H
2.21.017	30	80°	150.00
2.21.018	35	80°	150.00
2.21.019	40	80°	150.00
2.21.020	50	80°	150.00
2.21.021	60	80°	150.00
2.21.022	80	80°	150.00
2.21.023	100	80°	150.00
2.21.024	120	80°	150.00



80°

	H	Mt
22.005	95,00	I

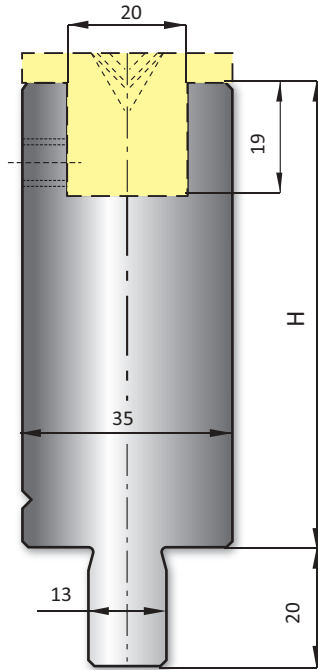

415 mm

835 mm

Weitere Möglichkeiten für abdruckfreies Kanten (ab S. 177)

	V	α
32.306	6	30°
32.308	8	30°
32.310	10	30°
32.406	6	45°
32.408	8	45°
32.410	10	45°
32.412	12	45°
32.606	6	60°
32.608	8	60°

	V	α
32.610	10	60°
32.612	12	60°
32.616	16	60°
32.806	6	88°
32.808	8	88°
32.810	10	88°
32.812	12	88°
32.816	16	88°

Mittel

415 mm

835 mm

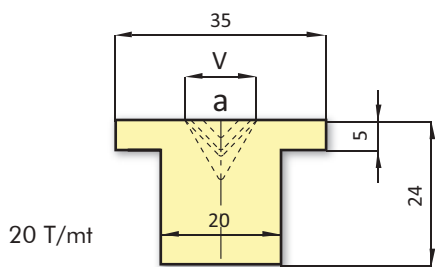

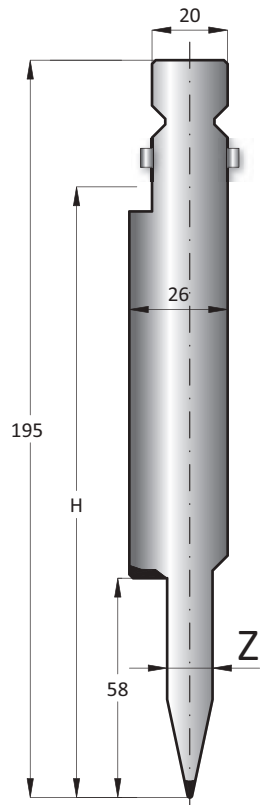

	α	R	H	Z	T/mt	Mt
15.902	24°	0.60	158.00	8	80	II
15.904	24°	0.60	158.00	10	80	II
15.905	24°	0.60	158.00	12	80	II

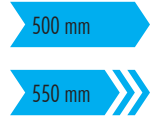

24°

	R	H	Z	T/mt	Mt
25.992	1.00	100.00	8,2	50	II
25.994	1.00	100.00	10,2	50	II
25.995	1.00	100.00	12,2	50	II

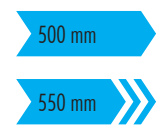
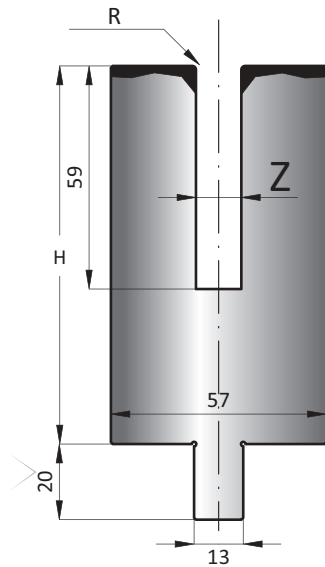

Green Line

Green Line

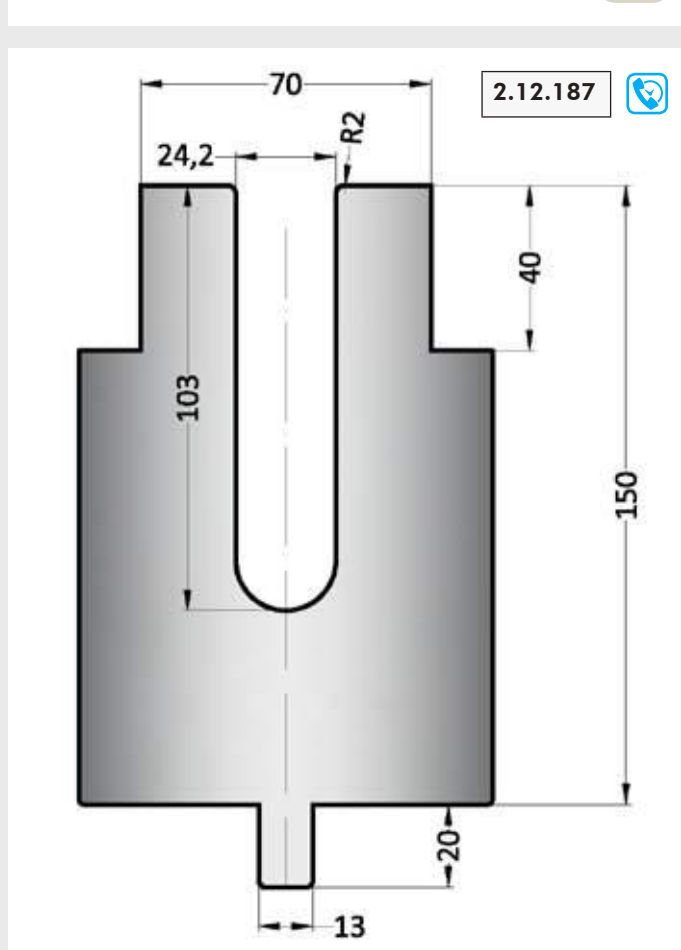
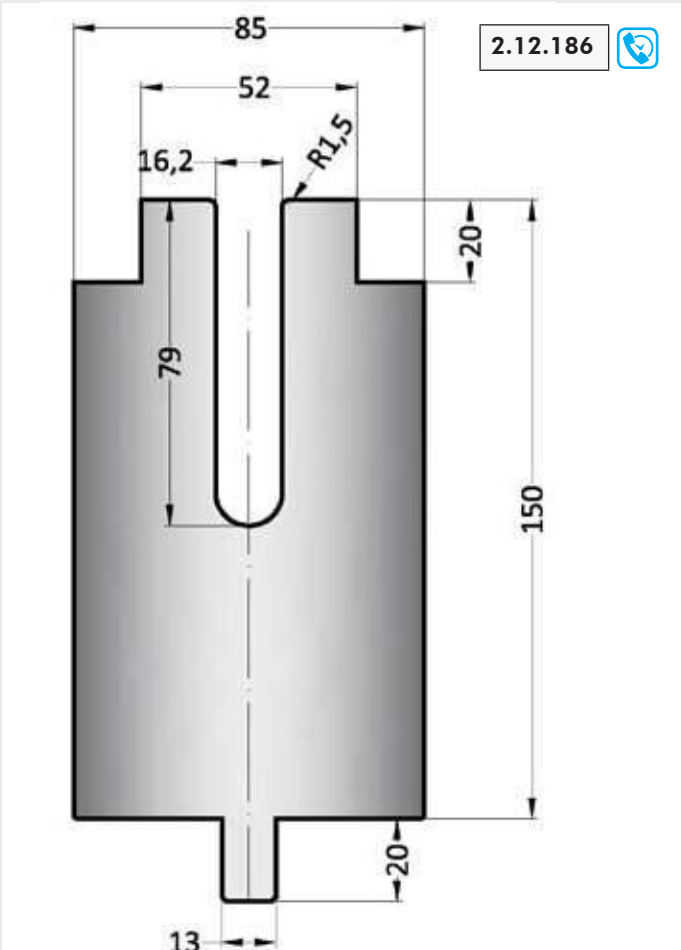
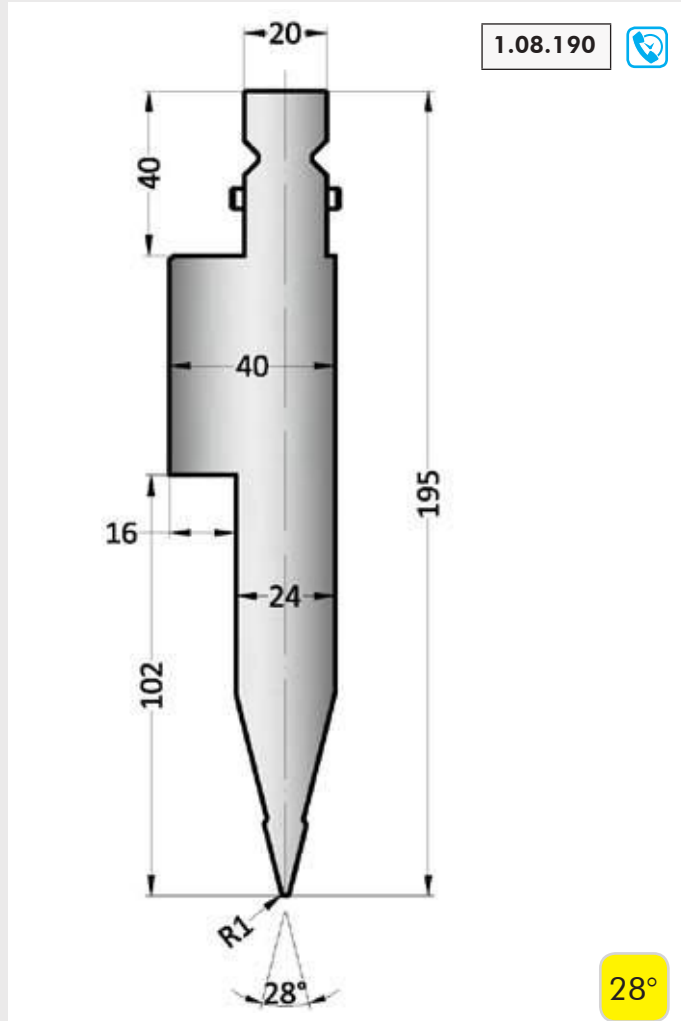
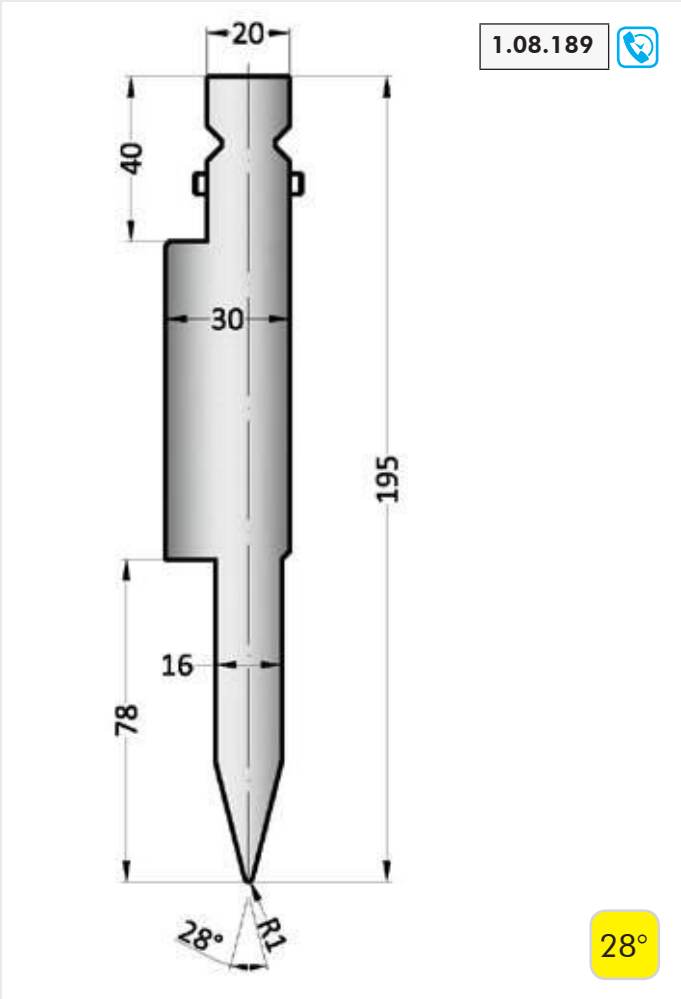

Oberwerkzeuge / Upper tools

direkt einsetzbar auf Abkantpressen von / directly able to work on bending presses of:

Bystronic-Beyeler: Euro A-Safan, R, RF, S, SF, RF-A

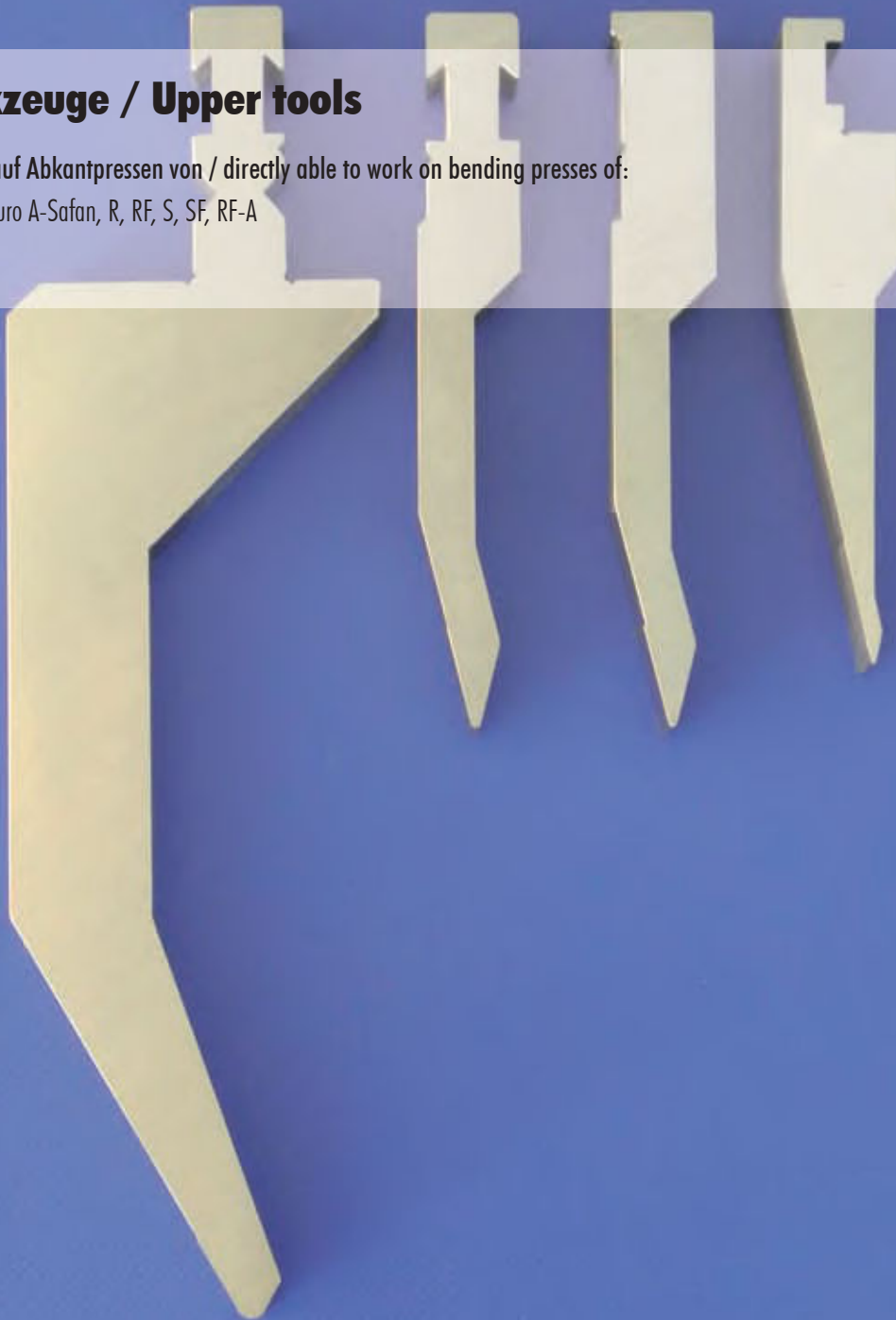

Yellow Line

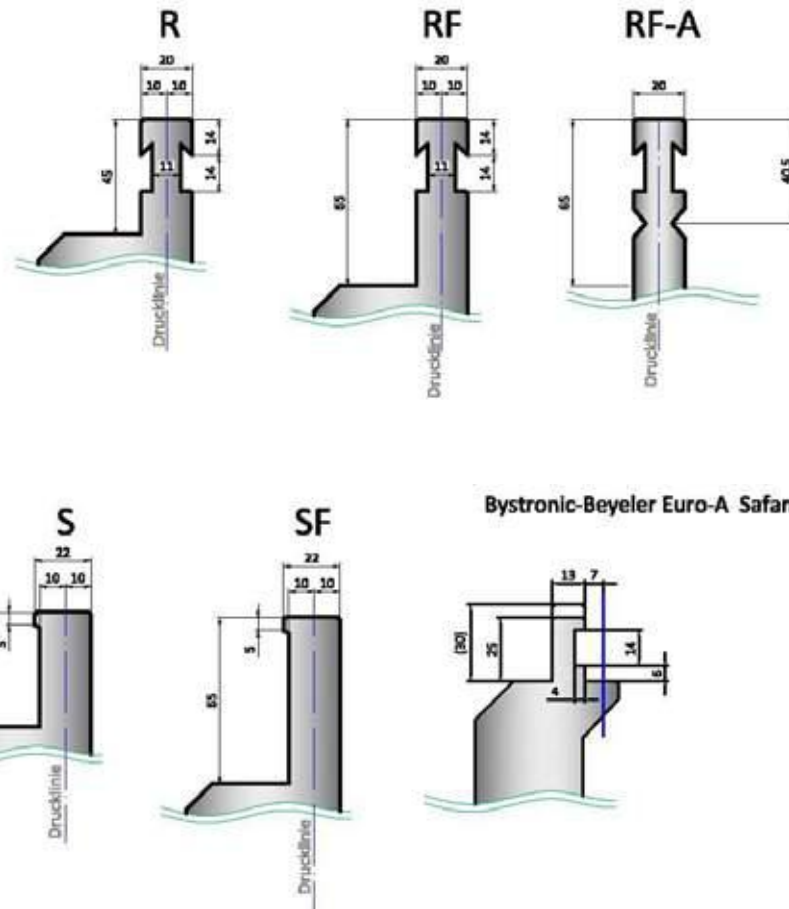

direkt einsetzbar auf Abkantpressen von:

Bystronic-Beyeler Euro A-Safan
Bystronic-Beyeler R
Bystronic-Beyeler RF
Bystronic-Beyeler S
Bystronic-Beyeler SF
Bystronic-Beyeler RF-A

Material:

Westermann24 nutzt die vielfältigen Möglichkeiten der Werkstoffkunde, um Ihnen bestmögliche Qualität zu garantieren.

Verwendete Werkstoffe sind:

- I: C45
- II: C45, vergütet auf 800-850N/mm²
- III: 42CrMo4, vergütet auf 950-1050N/mm²
- Werkzeuge auf Anfrage: 1.2312, vergütet auf 1000-1200N/mm²

Ausführung:

Alle Biegeradien sind geschliffen und gehärtet

Werkzeuglängen:

Die Werkzeuglängen sind bei den Artikelnummern angegeben. Artikelnummern ohne Längenangabe sind auf Anfrage.

sektionierte Werkzeugsätze:

Oberwerkzeuge:
OW 1100mm sektioniert in : 10,15,20,30,40,50,60,75,100,200,300,100 Horn links, 100 Horn rechts

Belastbarkeit:

Die Belastbarkeit der Werkzeuge ist bei den Artikelnummern angegeben. Werkzeuge die höher belastet werden sollen, können auf Anfrage konstruiert werden. (siehe Seite 161)

directly able to work on bending presses of:

Bystronic-Beyeler Euro A-Safan
Bystronic-Beyeler R
Bystronic-Beyeler RF
Bystronic-Beyeler S
Bystronic-Beyeler SF
Bystronic-Beyeler RF-A

material:

Westermann24 uses the many possibilities of the material engineering, to guarantee best quality.

used materials are:

- I: C45
- II: C45, tempered to 800-850N/mm²
- III: 42CrMo4, tempered to 950-1050N/mm²
- tools on request: 1.2312, tempered to 1000-1200N/mm²

design:

All radii are grinded and hardened

length of the tool:

The tool length are posted with the art-no. Article- number without length- determination are available on request.

tool sets divided into sections:

Upper tool:
OW 1100mm sectioned in : 10,15,20,30,40,50,60,75,100,200,300,100 horn left, 100 horn right

loading capacity:

The loading capacity of the tools is specified by the article number. Tools which will also be loaded more heavily, can be designed by agreement with the relevant application engineering. (see Page 161)

	α	R	H	T/mt	Mt
14.040	86°	1.00	95.00	75	II

500 mm

550 mm

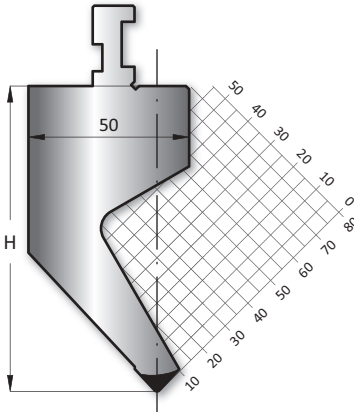

86°

	α	R	H	T/mt	Mt
14.020	80°	1.00	95.00	75	II

500 mm

550 mm

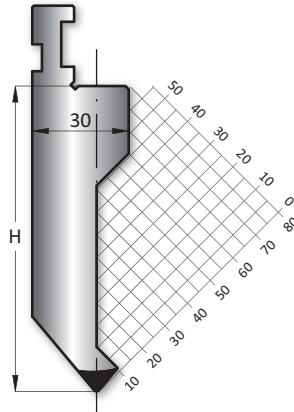

80°

	α	R	H	T/mt	Mt
14.060	80°	1.00	175.00	80	II

500 mm

550 mm

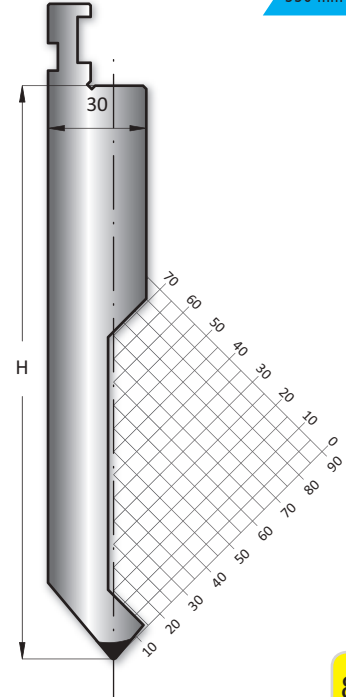

80°

	α	R	H	T/mt	Mt
14.010	60°	3.00	95.00	100	II

500 mm

550 mm

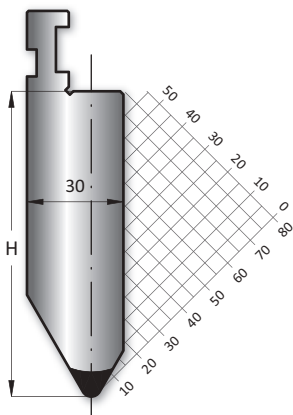

60°

	α	R	H	T/mt	Mt
14.050	28°	1.00	175.00	100	II

500 mm

550 mm

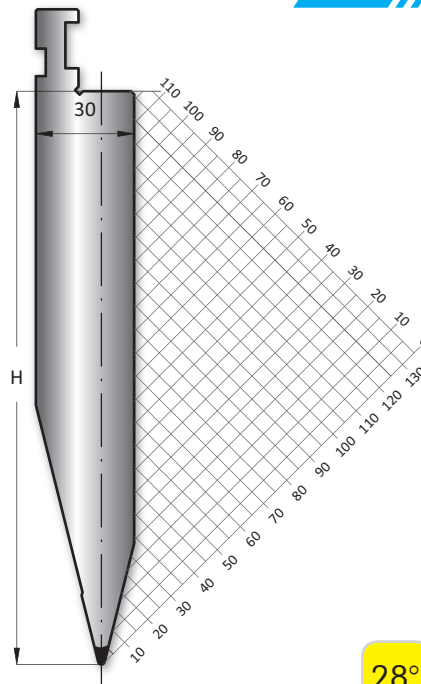

28°

	α	R	H	T/mt	Mt
14.030	28°	1.00	95.00	70	II

500 mm

550 mm

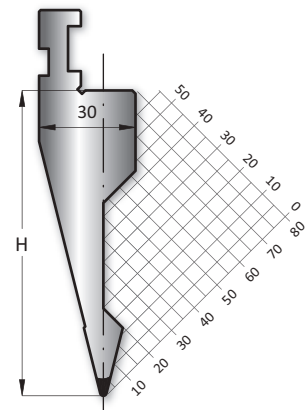

28°

Westermann24 entwickelt für Sie die richtige Werkzeugform für Ihr Produkt. (S. 161)

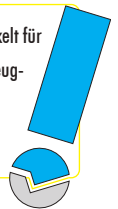

Yellow Line

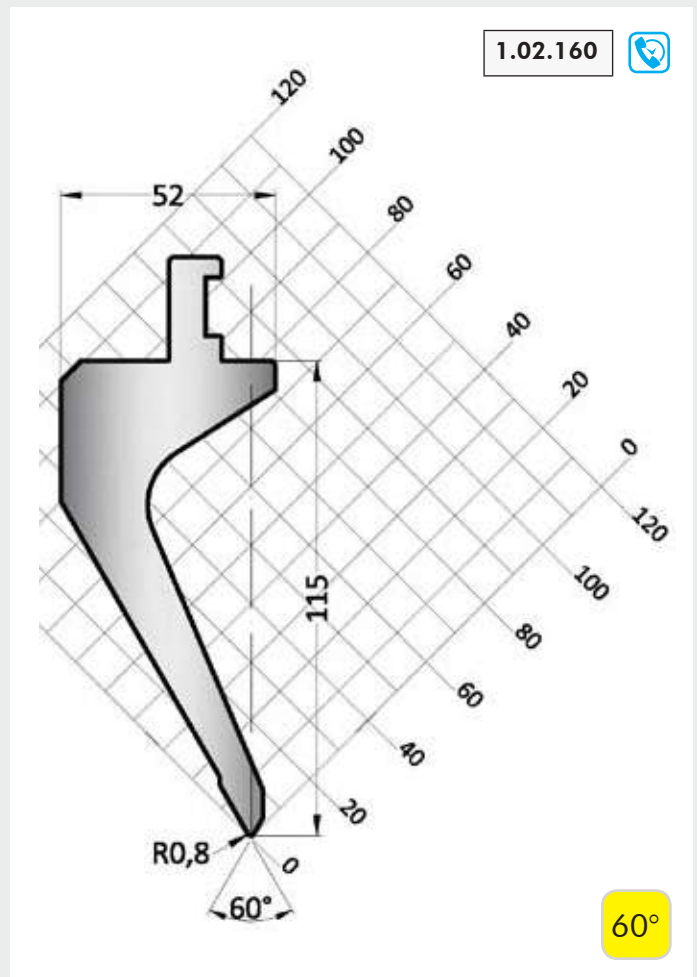
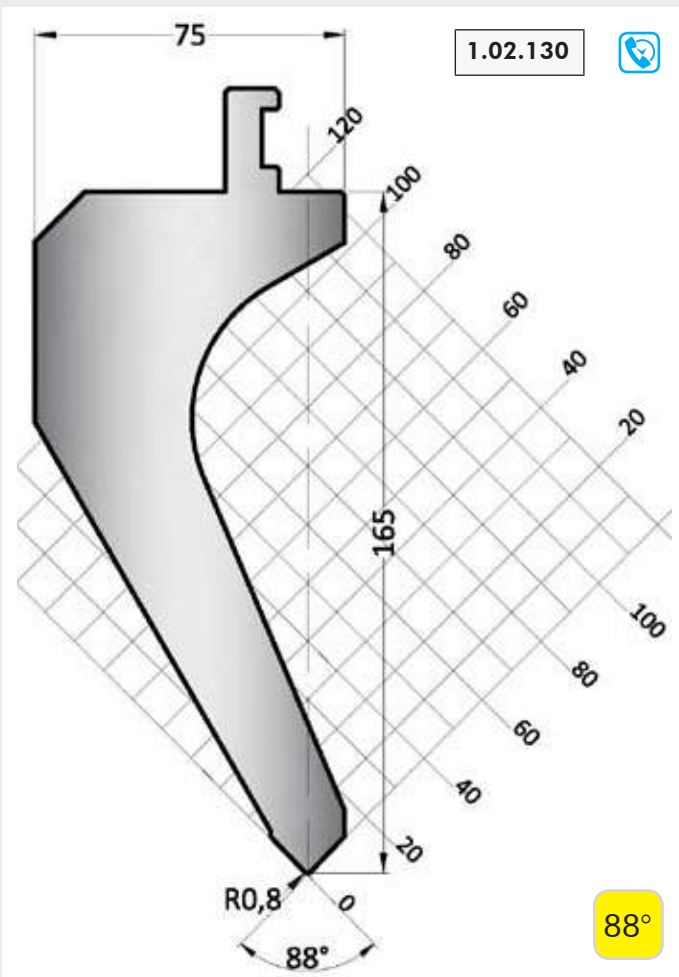
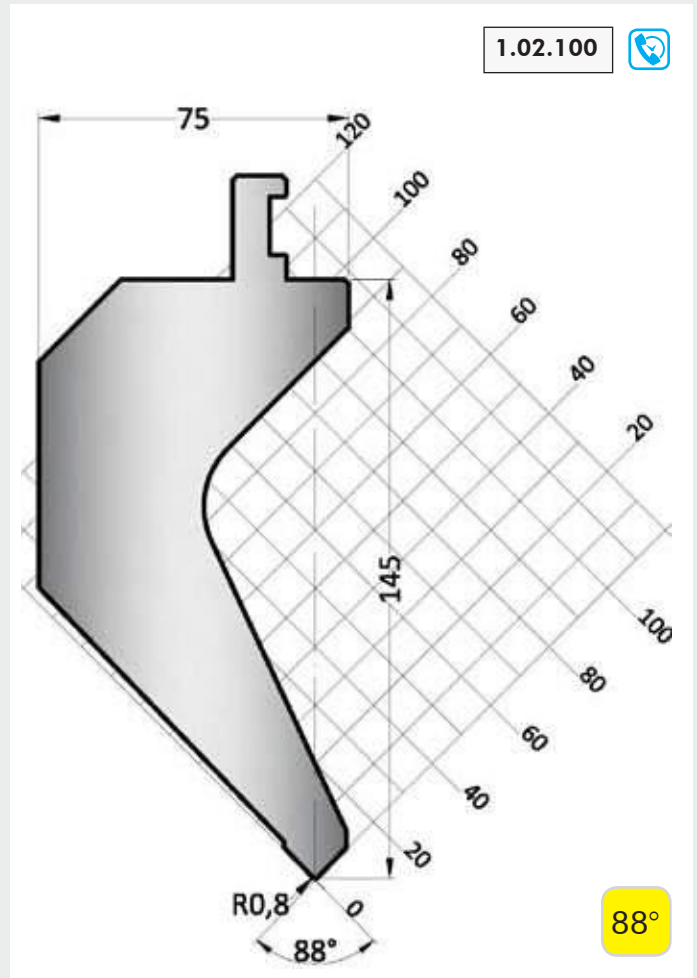
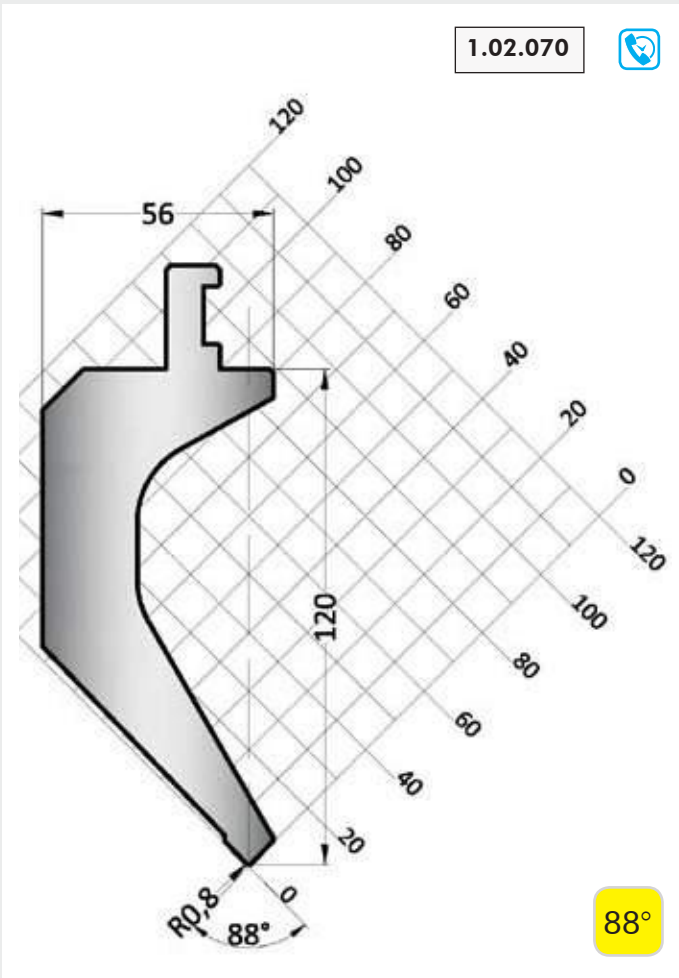

1.02.190

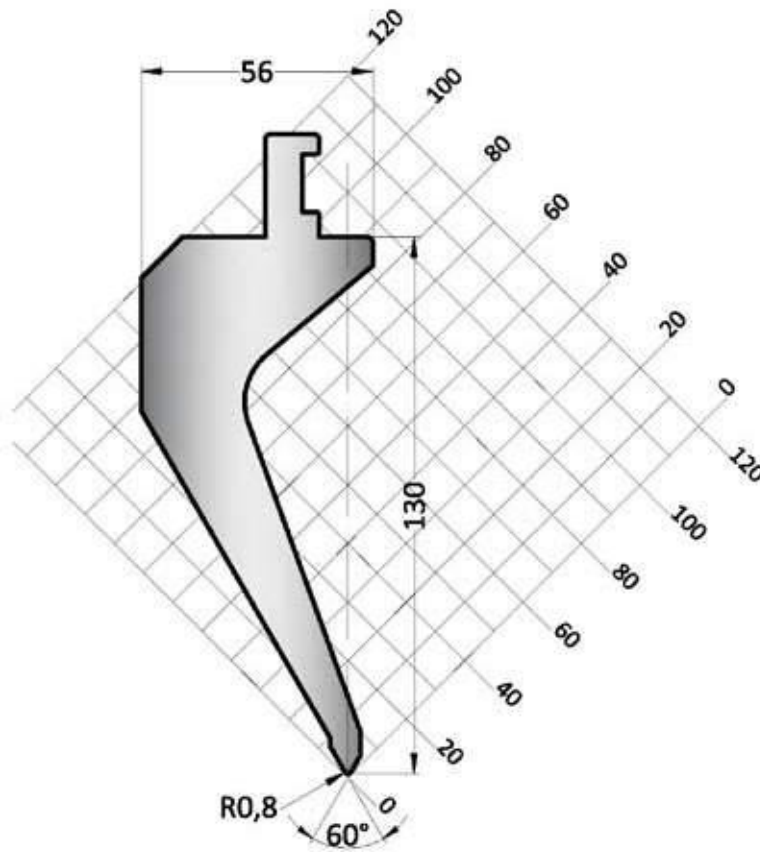

60°

1.02.220

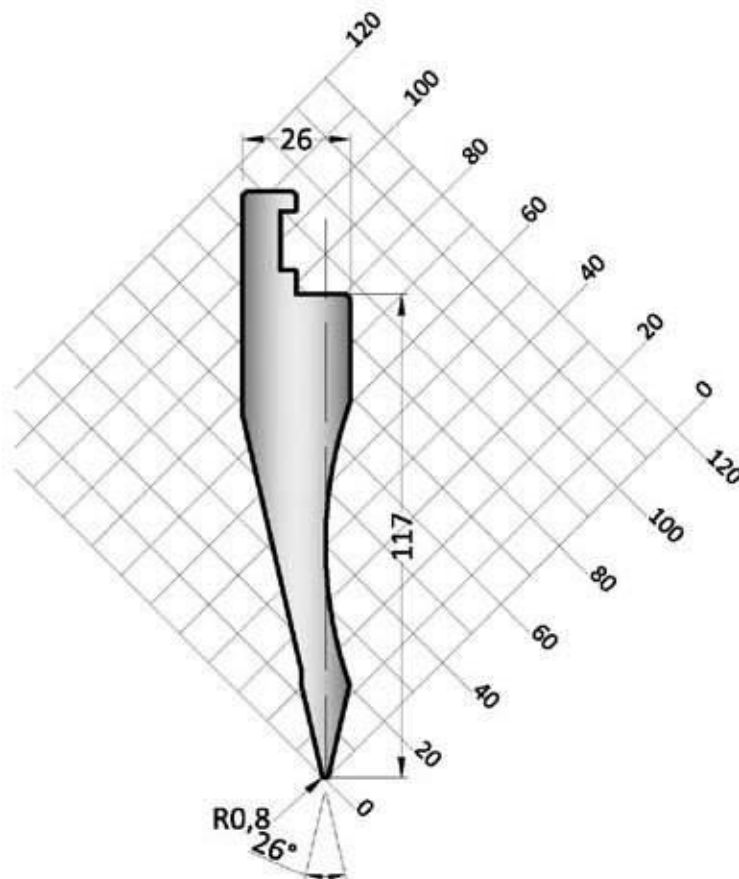

26°

Yellow Line

1.02.246



Yellow Line

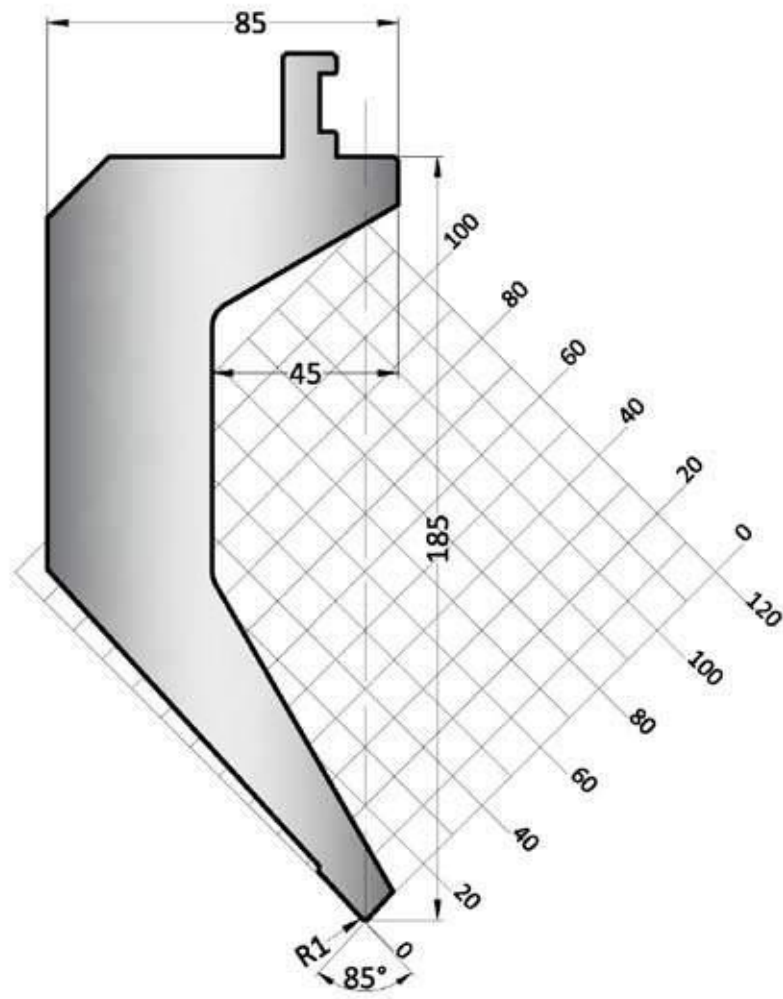

85°

1.02.247

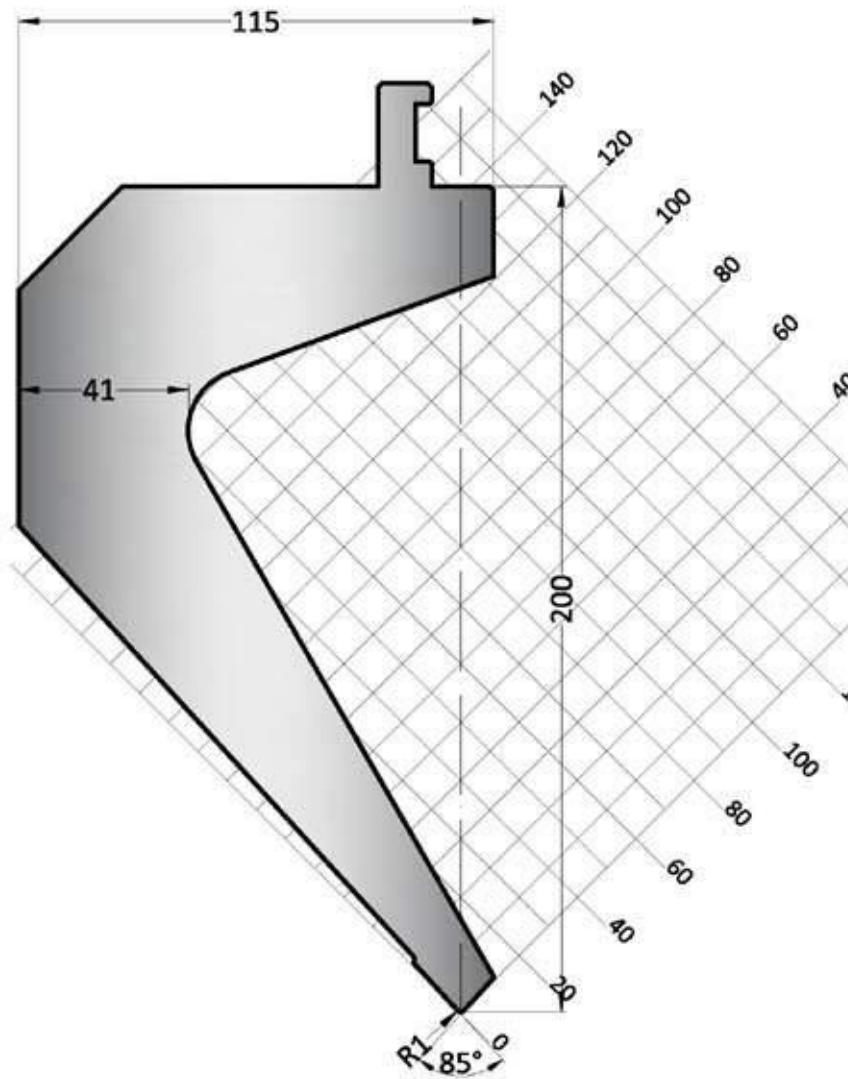

Yellow Line

85°

1.02.248



Yellow Line

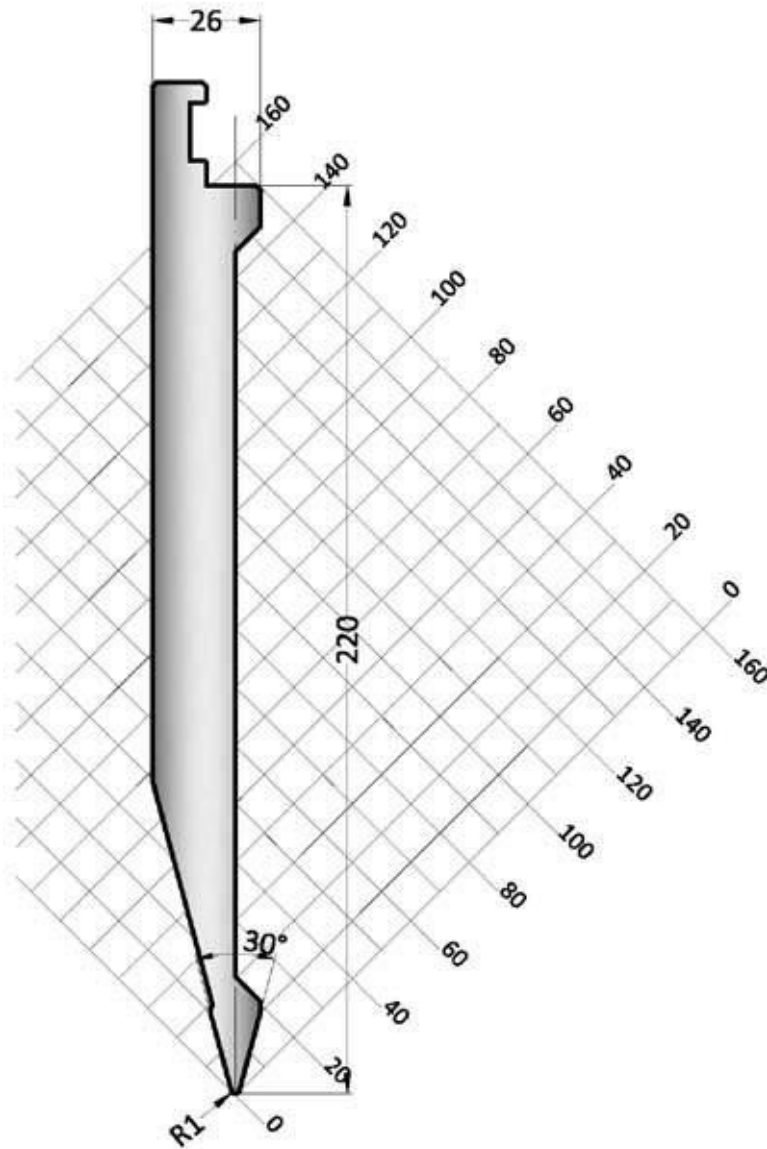

30°

1.02.249

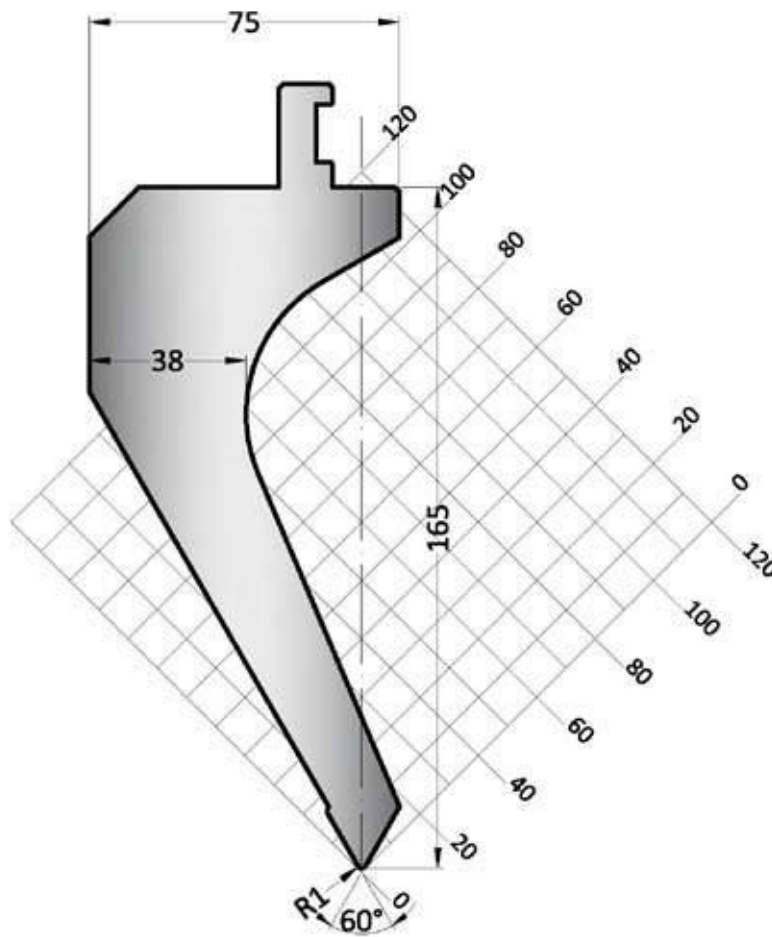

Yellow Line

60°

Yellow Line

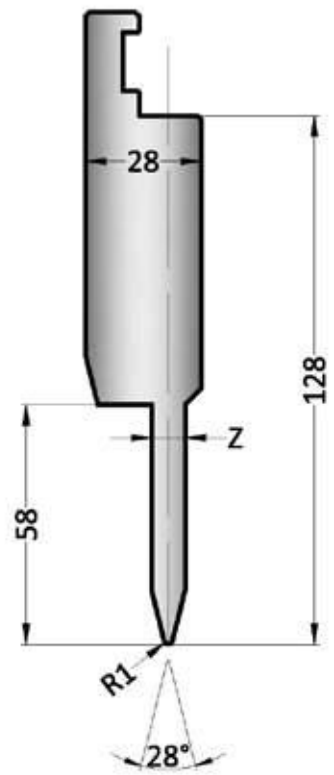

	α	R	Z	H
1.02.241	28°	1.00	8	128.00
1.02.242	28°	1.00	10	128.00
1.02.243	28°	1.00	12	128.00



28°

	R	Z	H
20.550	1.00	8,2	80.00
20.554	1.00	10,2	80.00
20.560	1.00	12,2	80.00

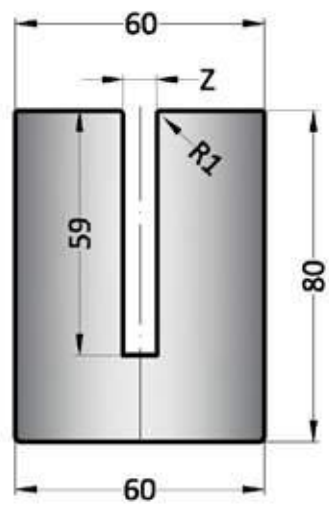

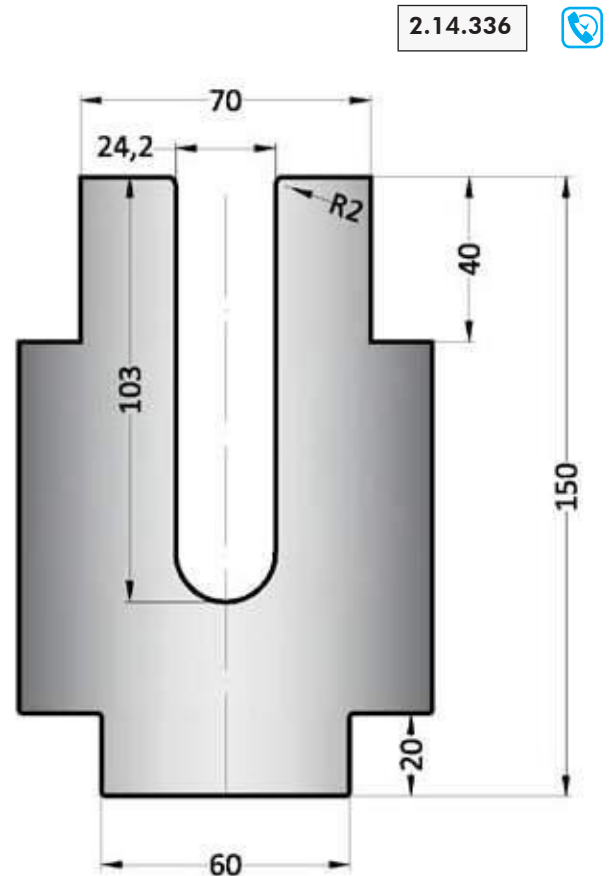
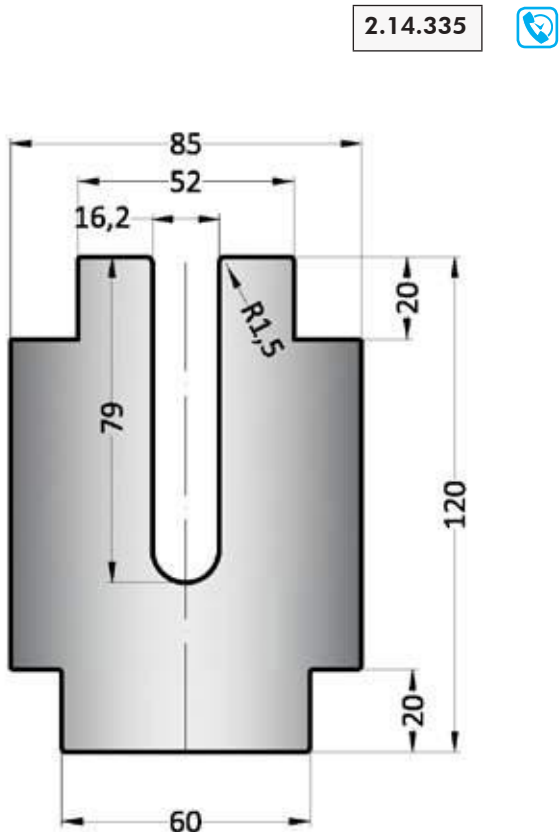
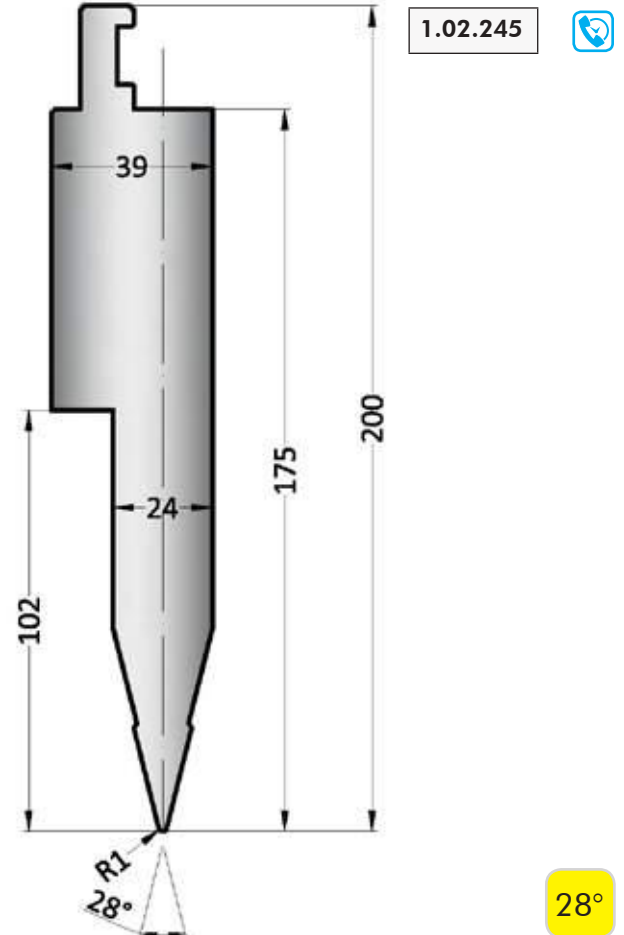
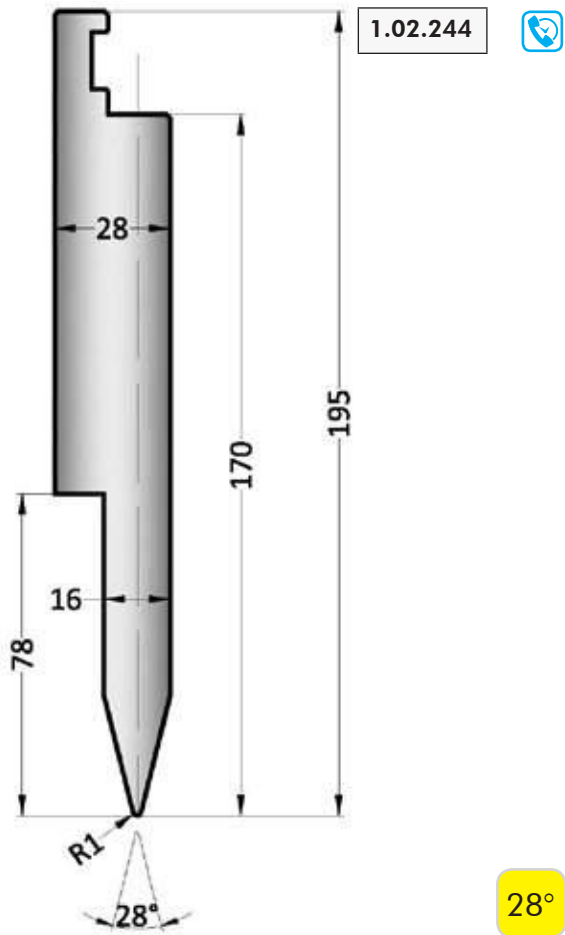

Yellow Line

Yellow Line

	Typ	α	R	H	T/mt	Mt
14.105	R	85°	0.80	155.00	50	III
14.106	S	85°	0.80	155.00	50	III

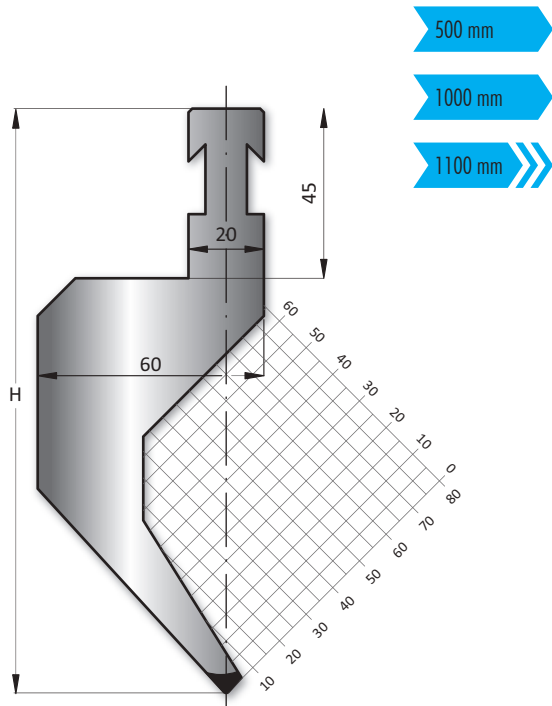

85°

	Typ	α	R	H	T/mt	Mt
14.209	R	85°	1.00	155.00	100	III
14.210	S	85°	1.00	155.00	100	III

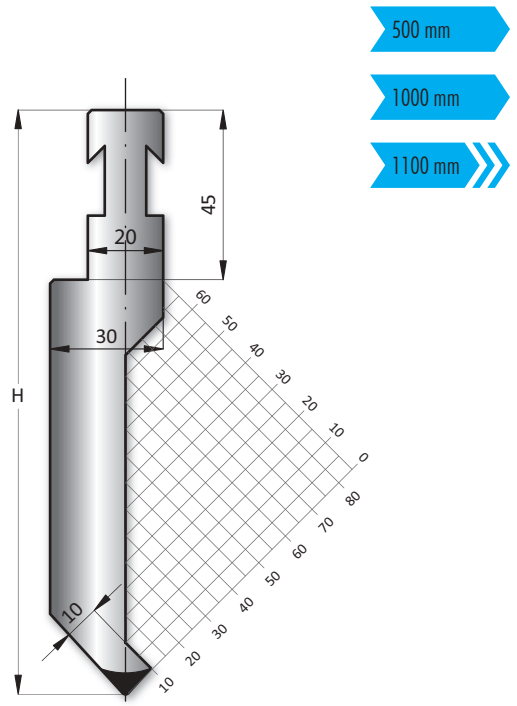

85°

	Typ	α	R	H	T/mt	Mt
14.300	R	30°	3.00	155.00	100	II
14.211	S	30°	3.00	155.00	10	II

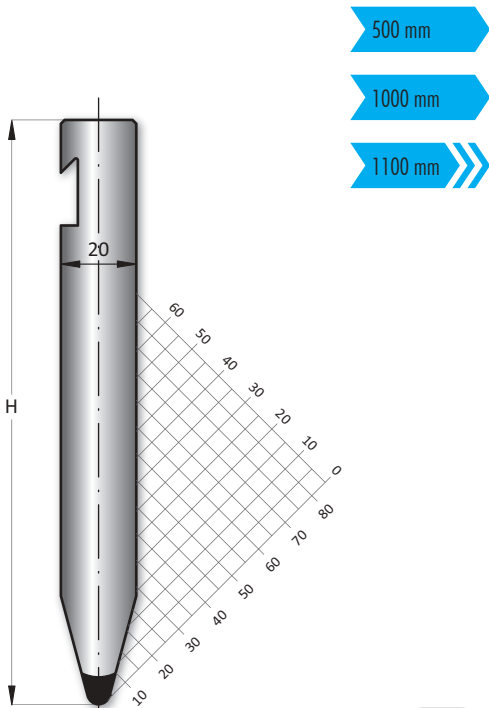

30°

	Typ	α	R	H	T/mt	Mt
14.330	R	30°	1.00	155.00	80	III
14.101	S	30°	1.00	155.00	80	III

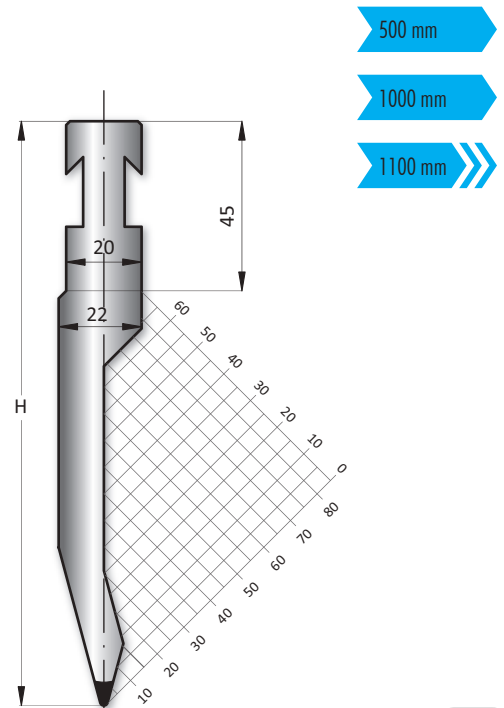

30°

	α	R	H	T/mt	Mt
14.353	88°	1.00	175.00	100	III

500 mm
1000 mm
1100 mm

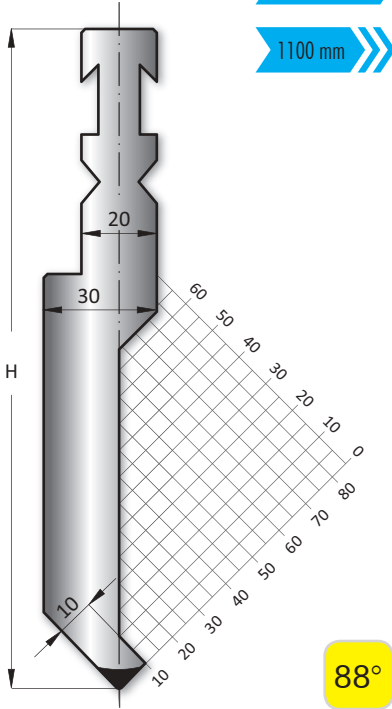

88°

	α	R	H	T/mt	Mt
14.363	88°	1.00	175.00	100	III

500 mm
1000 mm
1100 mm

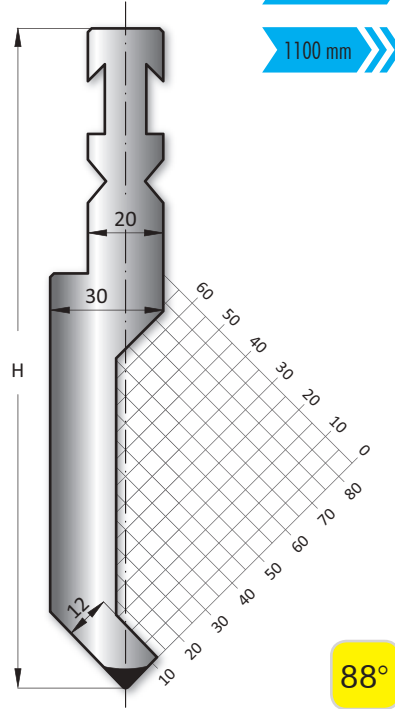

88°

	α	R	H	T/mt	Mt
14.383	88°	1.50	175.00	50	III

500 mm
1000 mm
1100 mm

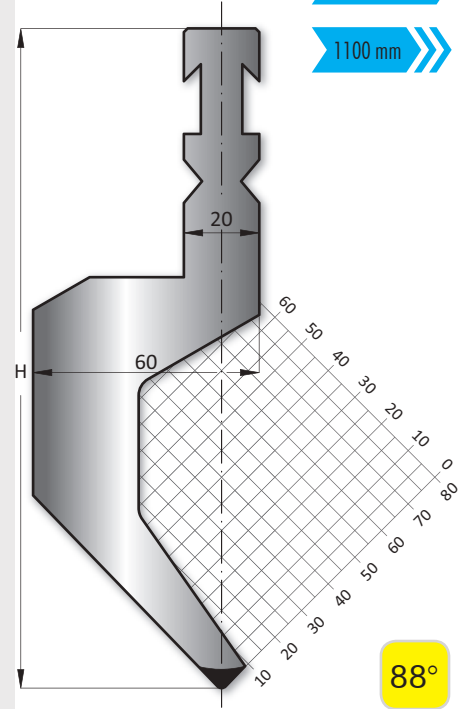

88°

	α	R	H	T/mt	Mt
14.313	30°	1.00	175.00	100	II

500 mm
1000 mm
1100 mm

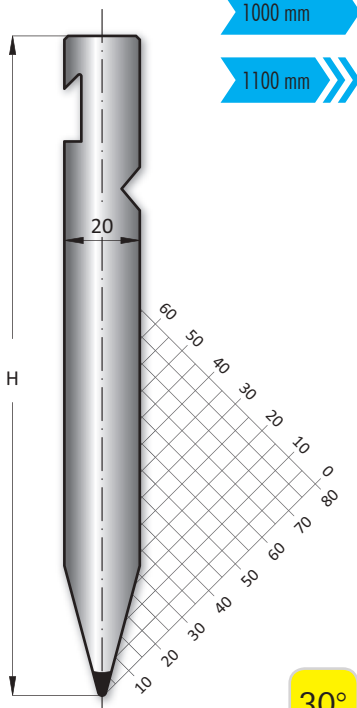

30°

	α	R	H	T/mt	Mt
14.303	30°	3.00	175.00	100	II

500 mm
1000 mm
1100 mm

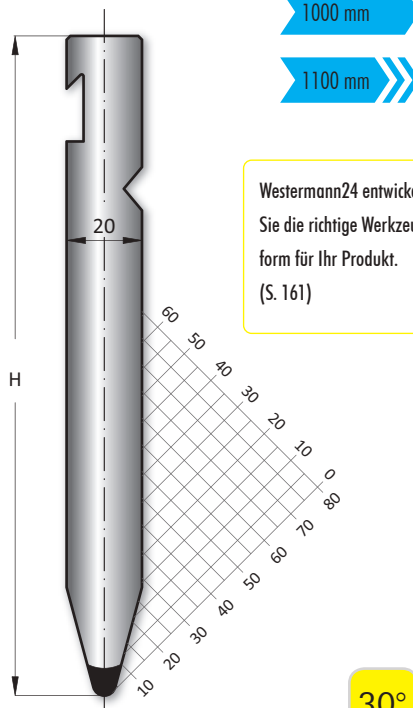

30°

Westermann24 entwickelt für Sie die richtige Werkzeugform für Ihr Produkt. (S. 161)

	α	R	H	T/mt	Mt
14.333	30°	1.00	175.00	80	III

500 mm
1000 mm
1100 mm

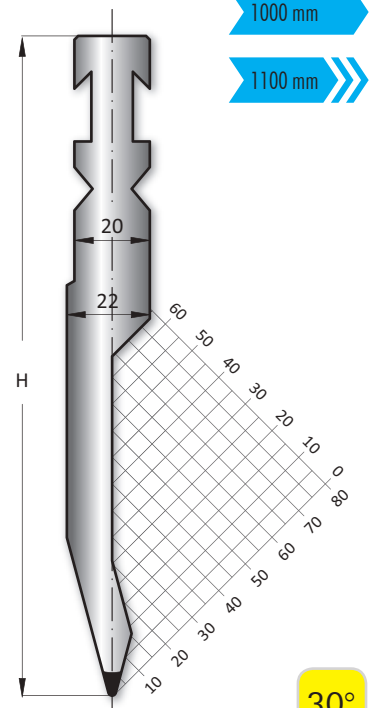

30°

Yellow Line

Yellow Line

	α	R	H	T/mt	Mt
14.460	85°	1.50	250.00	50	III

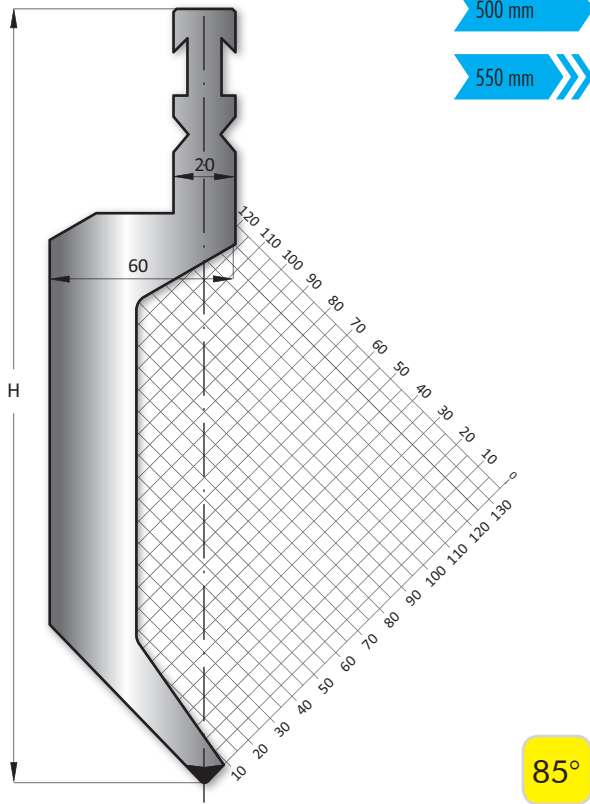

	α	R	H	T/mt	Mt
14.450	85°	1.00	250.00	100	III

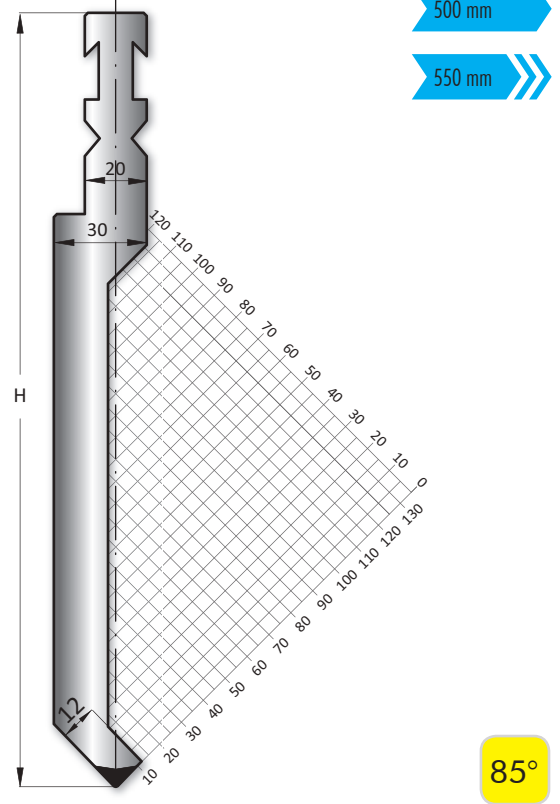

	α	R	H	T/mt	Mt
14.440	85°	1.00	250.00	100	III

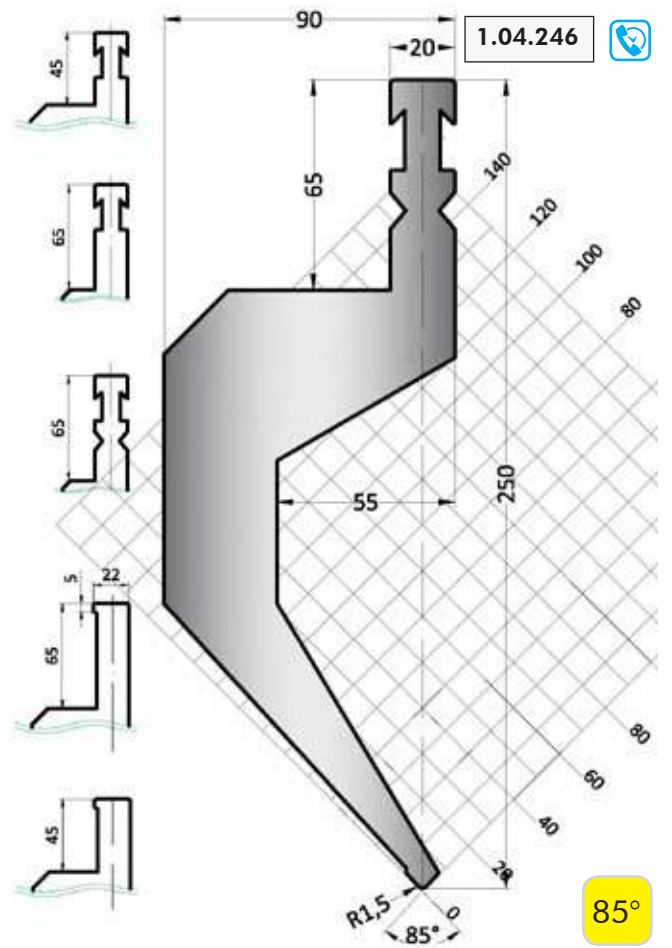
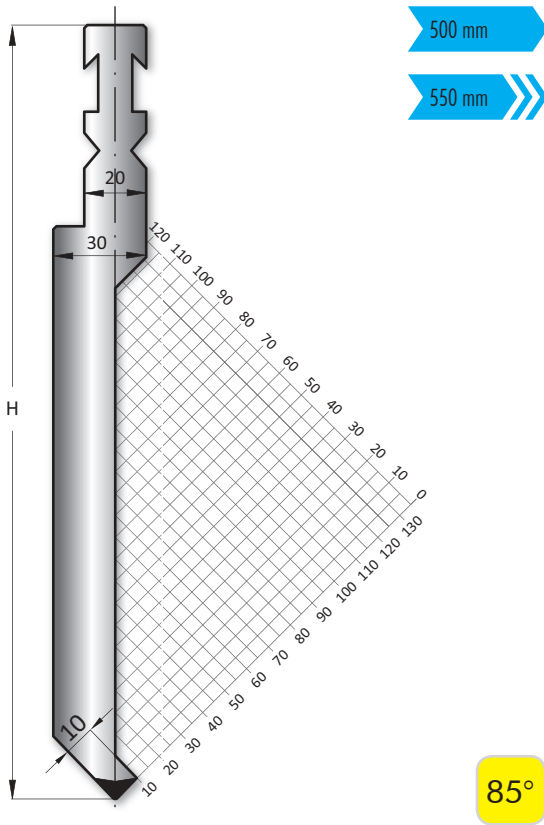

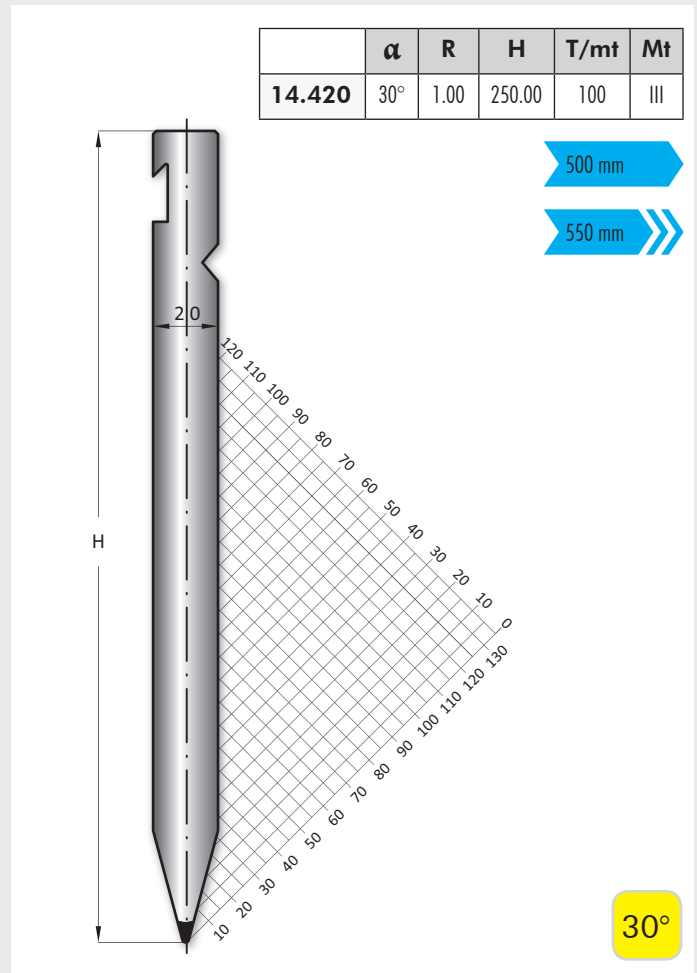
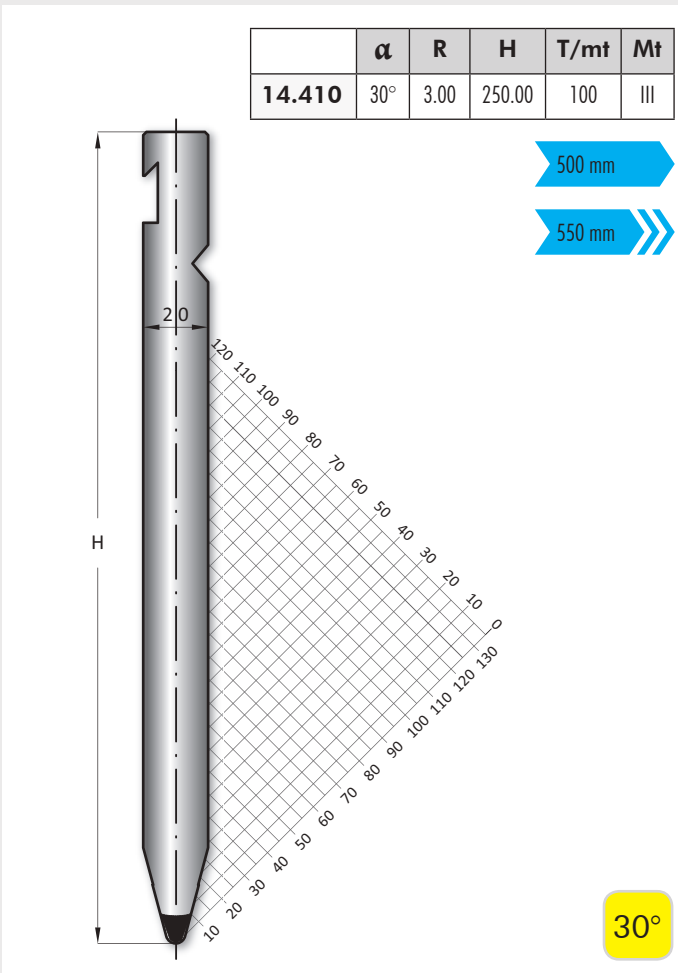
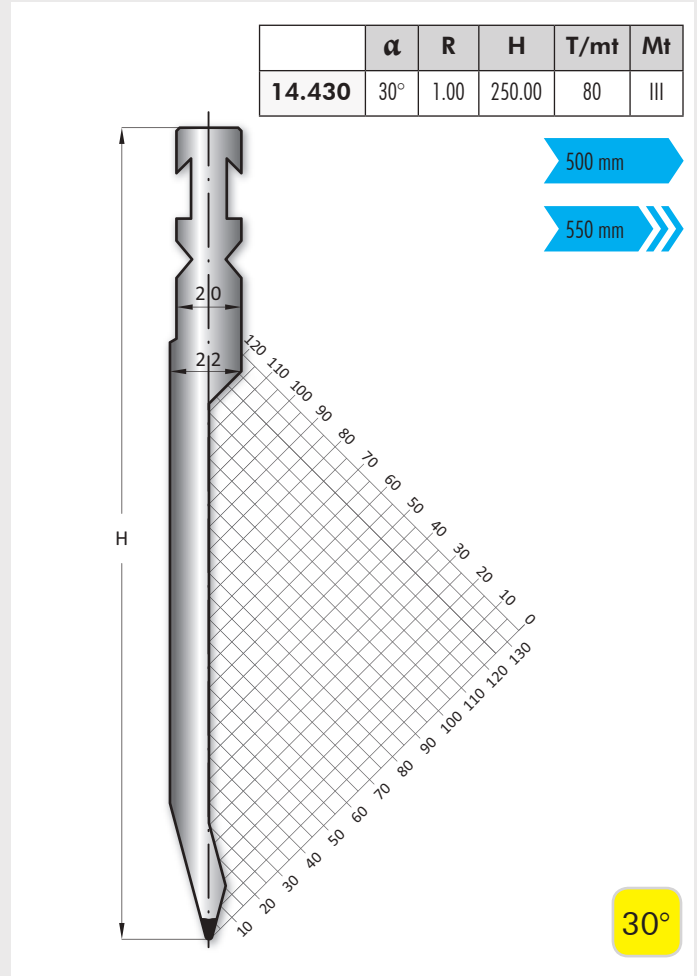
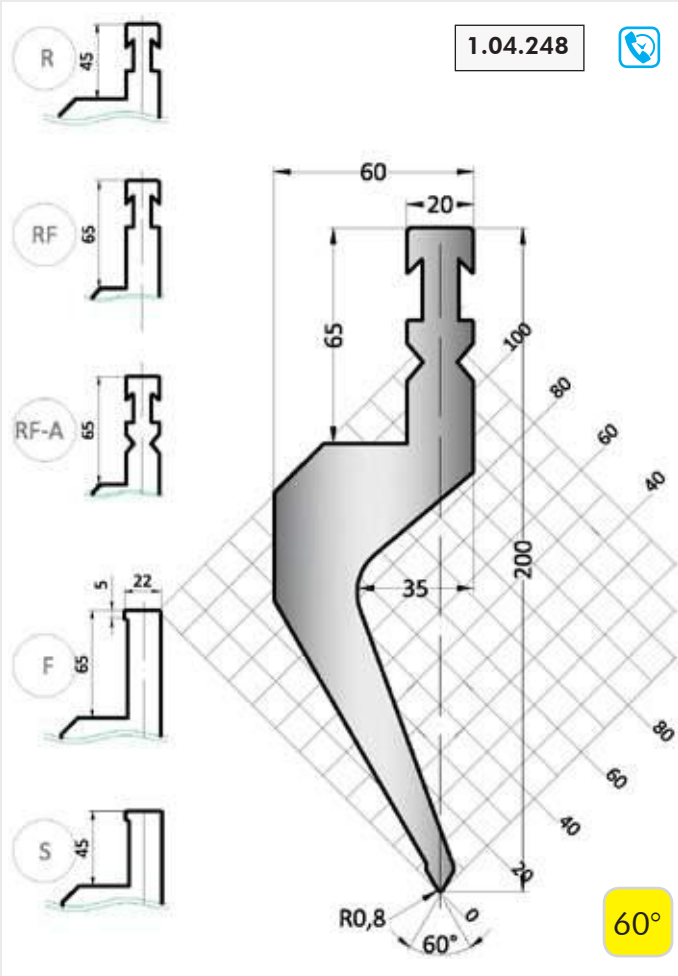

Yellow Line

Yellow Line

	Typ	H	Mt
14.281	S	90.00	III

- 100 mm
- 500 mm
- 550 mm

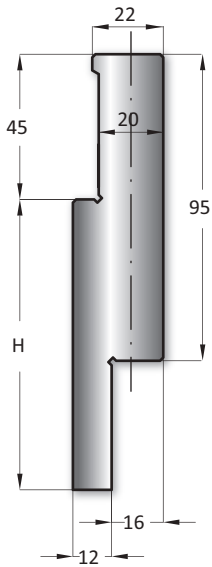

	Typ	H	Mt
14.280	R	90.00	III

- 100 mm
- 500 mm
- 550 mm

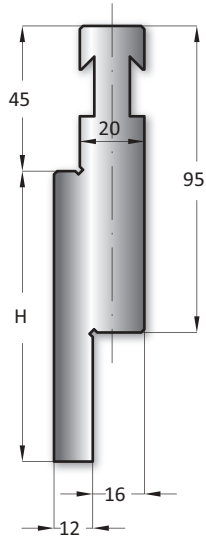

	α	R	H	T/mt	Mt
15.776	86°	1.00	100	100	III
15.774	84°	1.00	100	100	III
15.769	28°	6.00	100	100	III
15.768	28°	5.00	100	100	III
15.767	28°	4.00	100	100	III
15.766	28°	3.00	100	100	III
15.765	28°	2.00	100	100	III
15.763	28°	1.00	100	100	III
15.761	28°	0.50	100	100	III

- 100 mm
- 500 mm
- 550 mm

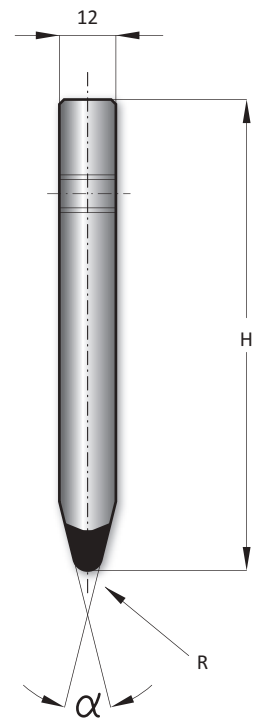

	Typ	H	Mt
14.282	RFA	70.00	III

- 100 mm
- 500 mm
- 550 mm

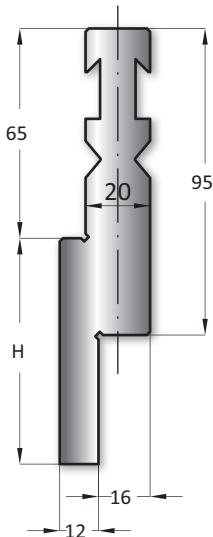

	Typ	H	Mt
14.400	EURO		

- 100 mm
- 500 mm
- 550 mm

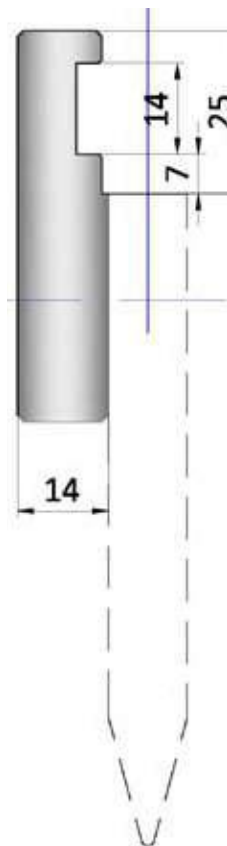

86°

84°

28°

	Typ	T/mt	Mt
14.095	EURO	100	I

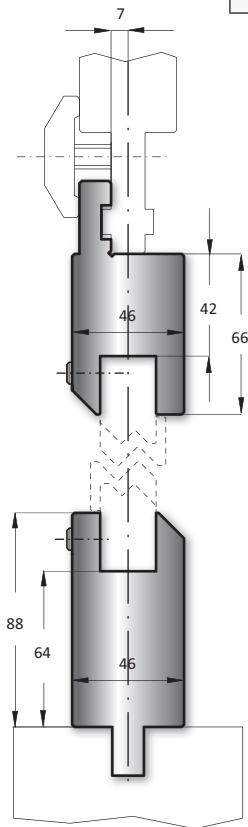

	Typ	T/mt	Mt
14.080	RFA	100	I

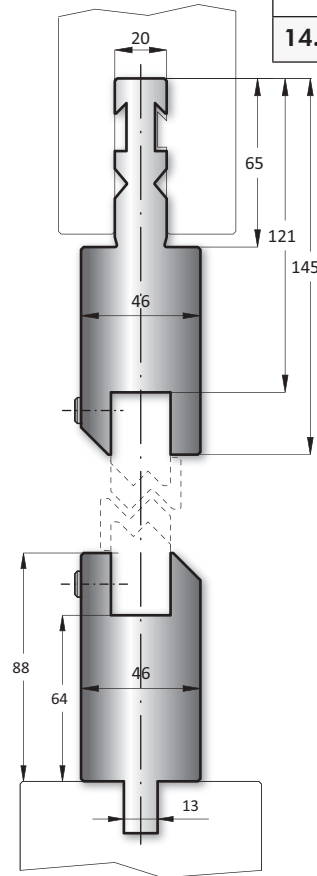

	Typ	T/mt	Mt
14.085	R	100	I

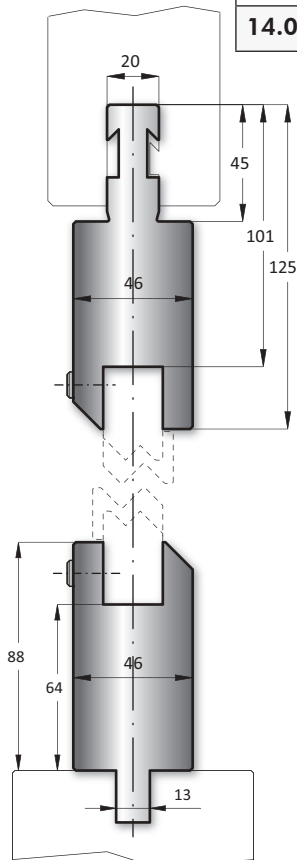

	Typ	T/mt	Mt
14.090	S	100	I

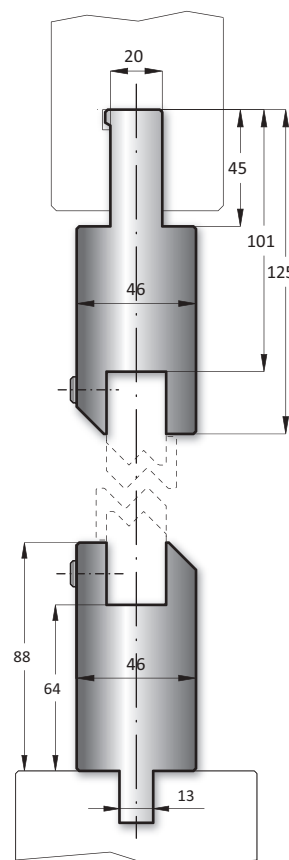

Yellow Line

415 mm
835 mm

	Z	α	T/mt	Mt
40.510	1.00	160°	100	I
40.515	1.50	160°	100	I
40.520	2.00	150°	100	I
40.525	2.50	140°	100	I

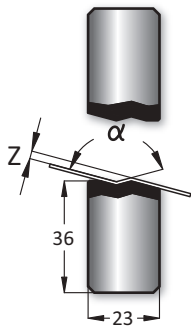

160°
150°
140°

415 mm
835 mm

	Z	α	T/mt	Mt
40.511	1.00	90°	100	I
40.516	1.50	90°	100	I
40.521	2.00	90°	100	I
40.526	2.50	90°	100	I
40.530	3.00	90°	100	I
40.535	3.50	90°	100	I
40.540	4.00	90°	100	I
40.545	4.50	90°	100	I
40.550	5.00	90°	100	I
40.555	5.50	90°	100	I
40.560	6.00	90°	100	I
40.565	6.50	90°	100	I
40.570	7.00	90°	100	I
40.575	7.50	90°	100	I
40.580	8.00	90°	100	I

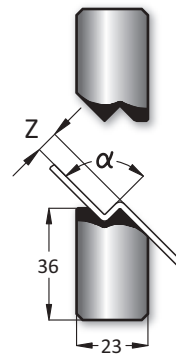

90°

415 mm
835 mm

	Z	α	T/mt	Mt
40.590	9.00	90°	100	I
40.610	10.00	90°	100	I
40.611	11.00	90°	100	I
40.612	12.00	90°	100	I

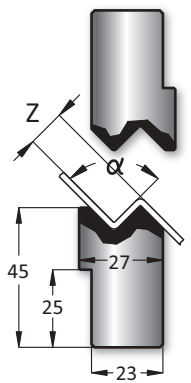

90°

415 mm
835 mm

	Z	α	T/mt	Mt
40.613	13.00	90°	100	I
40.614	14.00	90°	100	I
40.615	15.00	90°	100	I

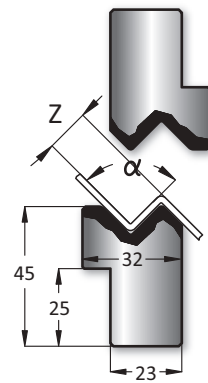

415 mm
835 mm
90°

415 mm
835 mm

	Z	α	T/mt	Mt
40.500				I

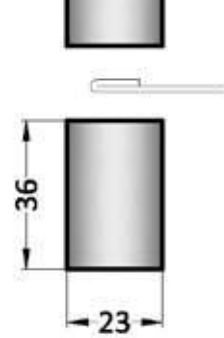

415 mm
835 mm
90°

	Typ	H	T/mt	Mt
14.251	S	140.00	80	I

412 mm

830 mm

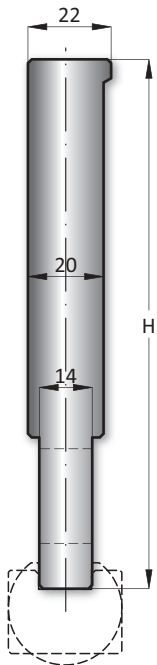

	Typ	H	T/mt	Mt
14.250	R	140.00	80	I

412 mm

830 mm

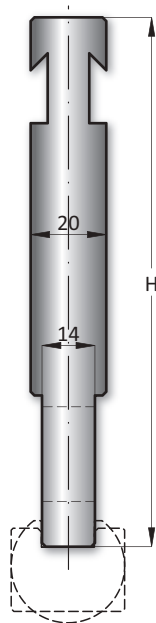

	Typ	H	T/mt	Mt
14.252	RFA	140.00	80	I

412 mm

830 mm

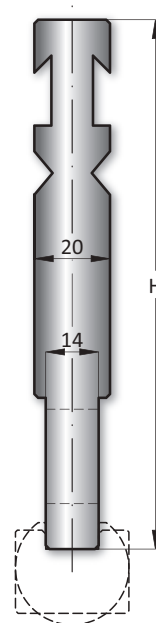

Yellow Line

415 mm

835 mm

	R	A
10.300	7.00	11.50
10.301	7.50	11.50
10.302	8.00	13.00
10.303	9.00	16.00
10.304	10.00	16.00
10.305	11.00	16.00
10.306	11.50	19.00
10.307	12.00	20.00

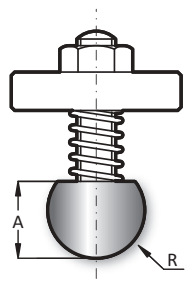

415 mm

835 mm

	R	A	B
10.308	12.50	16.00	21.00
10.309	13.00	17.00	23.00
10.310	14.00	19.00	25.00
10.311	15.00	20.00	27.00
10.312	16.00	21.00	28.00
10.313	17.00	21.50	31.50
10.314	17.50	22.00	32.00
10.315	19.00	25.00	32.00
10.316	20.00	24.00	34.00
10.317	22.50	25.00	33.00
10.318	25.00	29.00	39.00
10.319	27.50	34.00	44.00
10.320	30.00	34.00	44.00
10.321	35.00	45.00	55.00
10.322	40.00	45.00	55.00
10.323	45.00	50.00	60.00
10.324	50.00	54.00	64.00

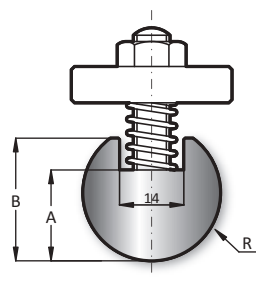

415 mm

835 mm

	A	B
10.325	17.00	22.00

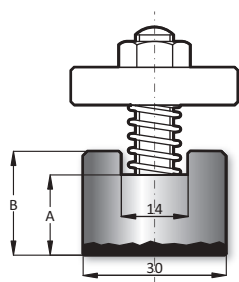

Westermann24 liefert
Ihnen Lösungen für
Halter mit Einsatz.
(S. 163)

Unterwerkzeuge / Lower tools

direkt einsetzbar auf Abkantpressen von / directly able to work on bending presses of:
Bystronic-Beyeler, Bystronic-Hämmerle, Safan, SMD, Trumpf, oder mit Tischnut für Zapfen 13 x 20 mm



Yellow Line

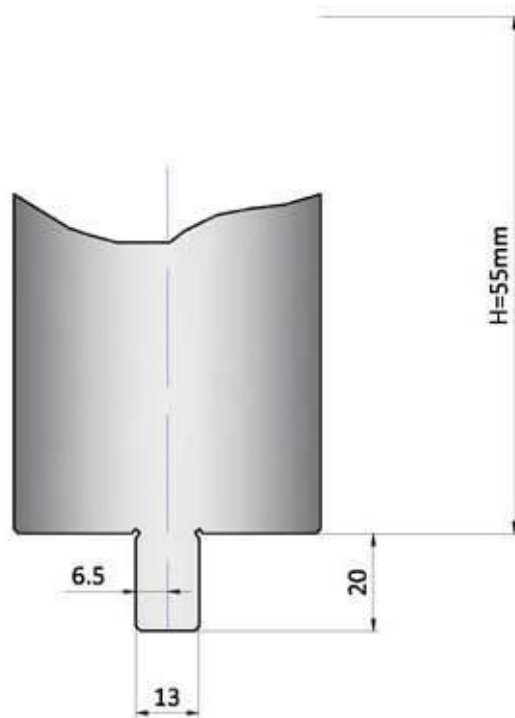

direkt einsetzbar auf Abkantpressen von:
Bystronic-Beyeler, Bystronic-Hämmerle, Safan, SMD, Trumpf, oder mit
Tischnut für Zapfen 13 x 20 mm

directly able to work on bending presses of:
Bystronic-Beyeler, Bystronic-Hämmerle, Safan, SMD, Trumpf, or with
table anchoring slots for pivots 13 x 20 mm

Material:

Westermann24 nutzt die vielfältigen Möglichkeiten der Werkstoffkunde, um Ihnen bestmögliche Qualität zu garantieren.

Verwendete Werkstoffe sind:

- I: C45
- II: C45, vergütet auf 800-850N/mm²
- III: 42CrMo4, vergütet auf 950-1050N/mm²
- Werkzeuge auf Anfrage: 1.2312, vergütet auf 1000-1200N/mm²

Ausführung:

Alle Biegeradien sind geschliffen und gehärtet

Werkzeuglängen:

Die Werkzeuglängen sind bei den Artikelnummern angegeben.
Artikelnummern ohne Längenangabe sind auf Anfrage.

sektionierte Werkzeugsätze:

Unterwerkzeuge:
UW 1100mm sektioniert in : 10,15,20,30,40,50,60,75,100,100,200,400mm

Belastbarkeit:

Die Belastbarkeit der Werkzeuge ist bei den Artikelnummern angegeben.
Werkzeuge die höher belastet werden sollen, können auf Anfrage konstruiert werden.
(siehe Seite 161)

material:

Westermann24 uses the many possibilities of the material engineering, to guarantee best quality.

used materials are:

- I: C45
- II: C45, tempered to 800-850N/mm²
- III: 42CrMo4, tempered to 950-1050N/mm²
- tools on request: 1.2312, tempered to 1000-1200N/mm²

design:

All radii are grinded and hardened

length of the tool:

The tool length are posted with the art-no.
Article- number without length- determination are available on request.

tool sets divided into sections:

Lower tool:
UW 1100mm sectioned in : 10,15,20,30,40,50,60,75,100,100,200,400mm

loading capacity:

The loading capacity of the tools is specified by the article number.
Tools which will also be loaded more heavily, can be designed by agreement with the relevant application engineering. (see Page 161)

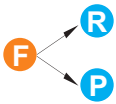

90°	V	R	H	B	T	F	T/mt	Mt
24.001	6	0,4	55	15	20	R 0,5	100	I
24.002	8	0,5	55	15	20	R 0,5	100	I
24.003	10	1,0	55	20	20	R 0,5	100	I
24.005	12	1,5	55	20	20	R 0,5	100	I
24.007	16	2,0	55	30	30	R 0,5	100	I

88°	V	R	H	B	T	F	T/mt	Mt
24.004	10	1,0	55	20	20	R 0,5	100	I
24.006	12	1,5	55	20	20	R 0,5	100	I
24.008	16	2,0	55	30	30	R 0,5	100	I
24.009	20	2,0	55	30	30	R 0,5	100	I
24.010	24	3,0	55	40	40	R 0,5	100	I

85°	V	R	H	B	T	F	T/mt	Mt
24.011	32	4,0	55	50	50	R 3,0	100	I
24.012	40	4,0	55	55	55	R 4,0	100	I

80°	V	
2.10.217	16	
2.10.218	20	
2.10.219	24	
2.10.220	30	
2.10.221	35	
2.10.222	40	
2.10.223	50	
2.10.224	60	

60°	V	R	H	B	T	F	T/mt	Mt
2.10.211	16							
2.10.212	20							
2.10.213	24							
2.10.214	30							
2.10.215	35							
24.040	40	5,0	55	55	55	R 5,0	100	I
24.050	50	5,0	55	70	70	P 15,0	100	I
24.060	60	7,0	65	80	80	P 15,0	100	I

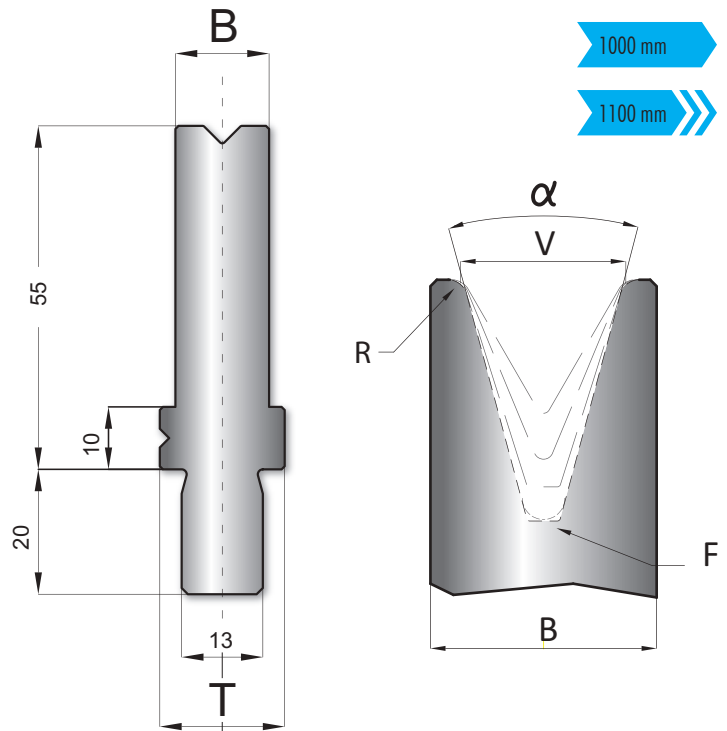

H=55

H=60

H=65

500 mm

1000 mm

1100 mm

Yellow Line

Legende - Legend	Technik - technique
F = Nutgrund - ground of the groove	
R = radius	
P = flach - flat	

	α	V	R	H	B	T	F	T/mt	Mt
24.013	30°	6	0,6	55	15	20	R 1,0	35	III
24.014	30°	8	0,8	55	15	20	P 2,0	35	III
24.015	30°	10	1,0	55	20	20	P 2,0	50	III
24.016	30°	12	1,5	55	20	20	P 2,0	40	III
24.017	30°	16	2,0	55	30	30	P 5,0	45	III
24.019	30°	20	2,5	55	35	35	P 5,0	50	III
24.018	30°	24	3,0	55	40	40	P 8,0	50	III
24.035	30°	32	4,0	60	60	60	P 10,0	50	III

90°

88°

85°

80°

60°

30°

Yellow Line

	V	α	H
2.19.010	30	60°	55.00
2.19.011	35	60°	55.00
2.19.012	40	60°	55.00
2.19.013	50	60°	55.00

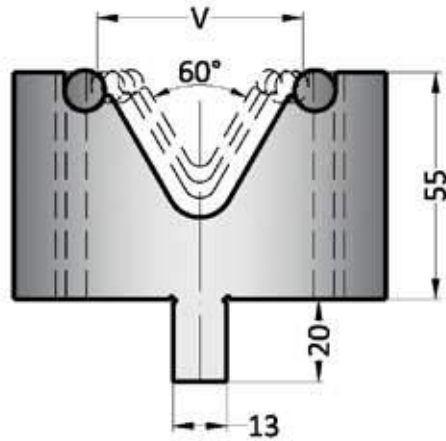

Westermann-Steckmatrize - mit Einlaufwellen 60°

60°

	V	α	H
2.19.014	30	80°	55.00
2.19.015	35	80°	55.00
2.19.016	40	80°	55.00
2.19.017	50	80°	55.00
2.19.018	60	80°	55.00

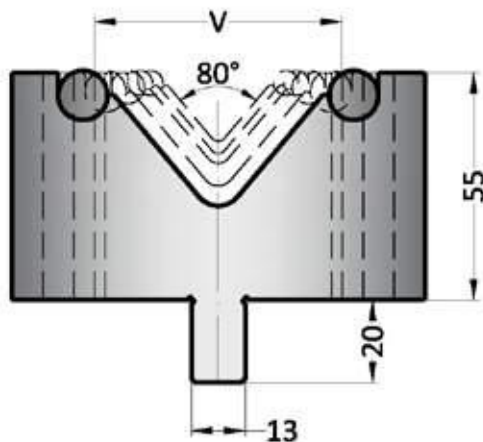

Westermann-Steckmatrize - mit Einlaufwellen 80°

Westermann 24 liefert Ihnen Matrizen mit Welleneinsatz. (S. 162)

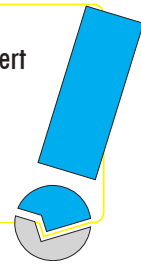

80°

	H	Mt
22.004	50.00	I

415 mm

835 mm

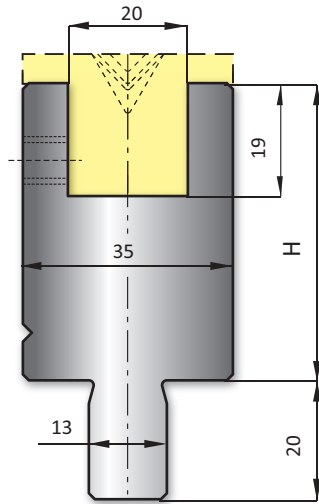

Weitere Möglichkeiten
für abdruckfreies
Kanten
(ab S. 177)

Yellow Line

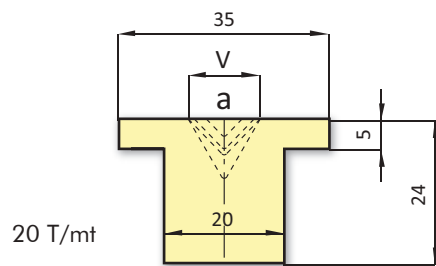

	V	α
32.306	6	30°
32.308	8	30°
32.310	10	30°
32.406	6	45°
32.408	8	45°
32.410	10	45°
32.412	12	45°
32.606	6	60°
32.608	8	60°

	V	α
32.610	10	60°
32.612	12	60°
32.616	16	60°
32.806	6	88°
32.808	8	88°
32.810	10	88°
32.812	12	88°
32.816	16	88°

415 mm

835 mm

Yellow Line

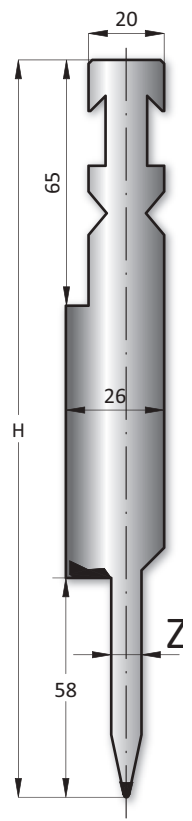

	α	R	H	Z	T/mt	Mt
14.908	24°	0.60	195.00	8	80	II
14.910	24°	0.60	195.00	10	80	II
14.912	24°	0.60	195.00	12	80	II

500 mm
550 mm

24°

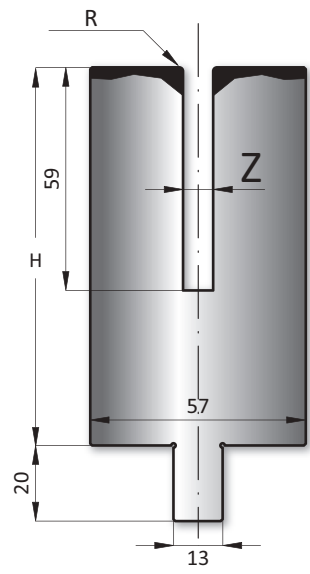

	R	H	Z	T/mt	Mt
25.992	1.00	100.00	8,2	50	II
25.994	1.00	100.00	10,2	50	II
25.995	1.00	100.00	12,2	50	II

500 mm
550 mm



1.04.252

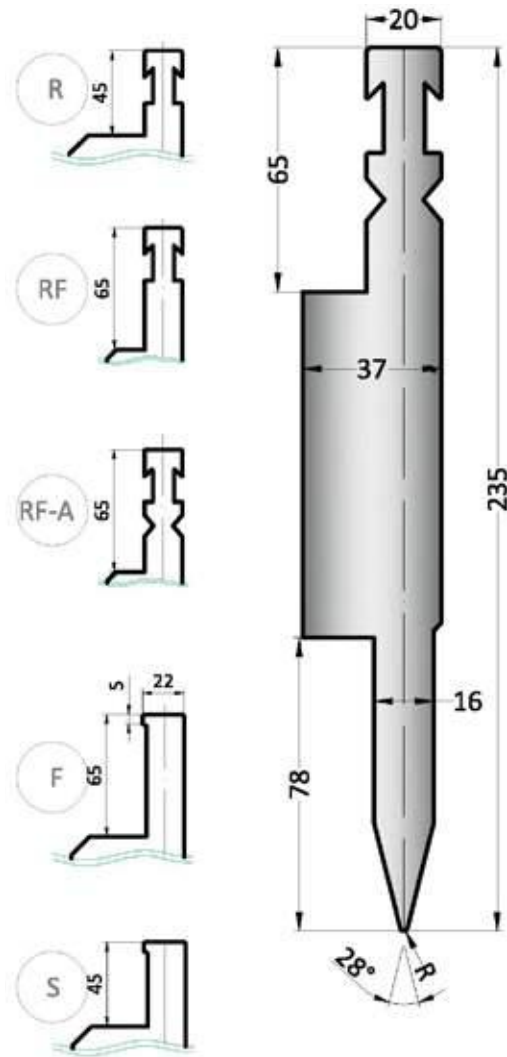

28°

2.12.186

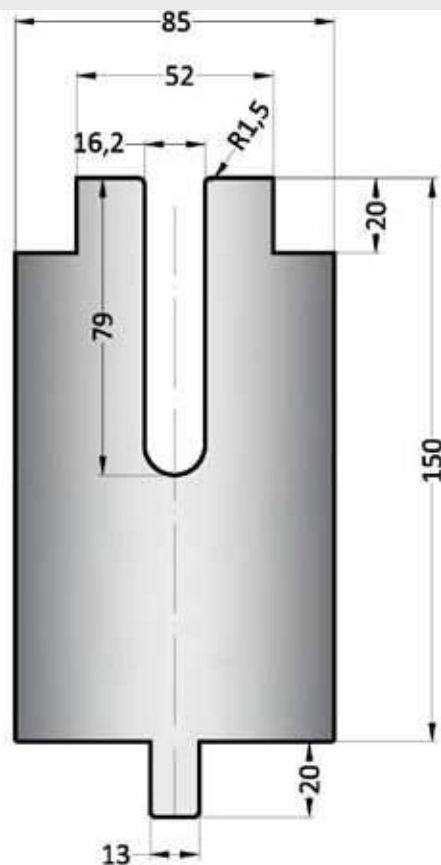

Yellow Line

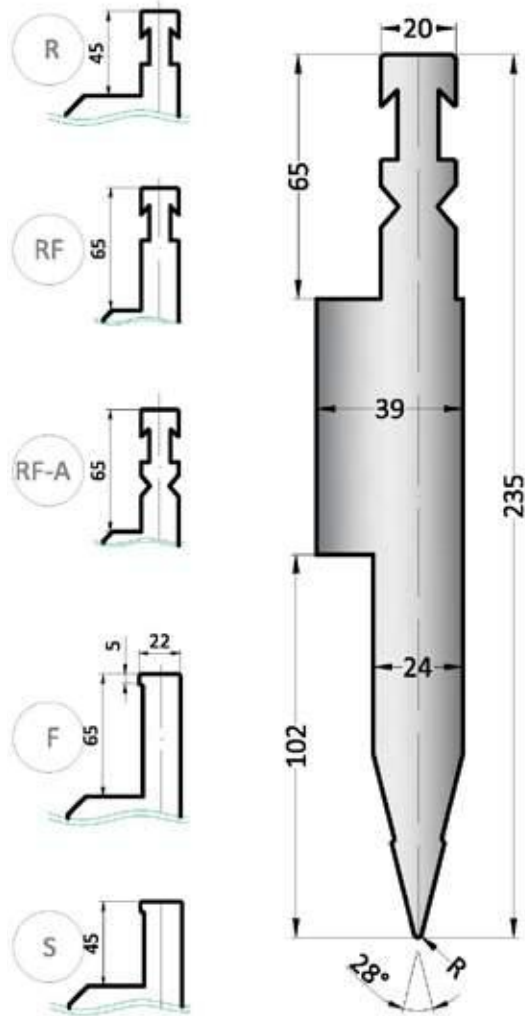

1.04.253



28°

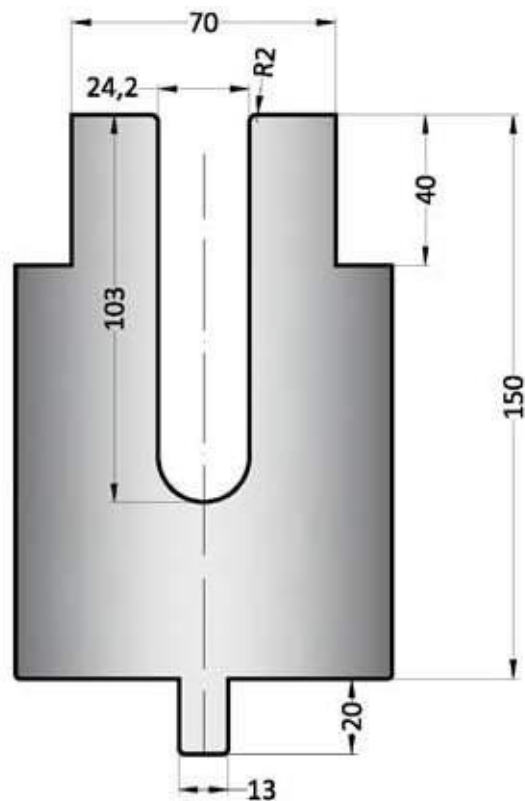

2.12.187



Ober- und Unterwerkzeuge / Upper and lower tools

direkt einsetzbar auf Abkantpressen von / directly able to work on bending presses of:
LVD (S. 102-112), EHT (S. 117-131), Weinbrenner (S. 132-151), Haco (S. 152-158)

Red Line

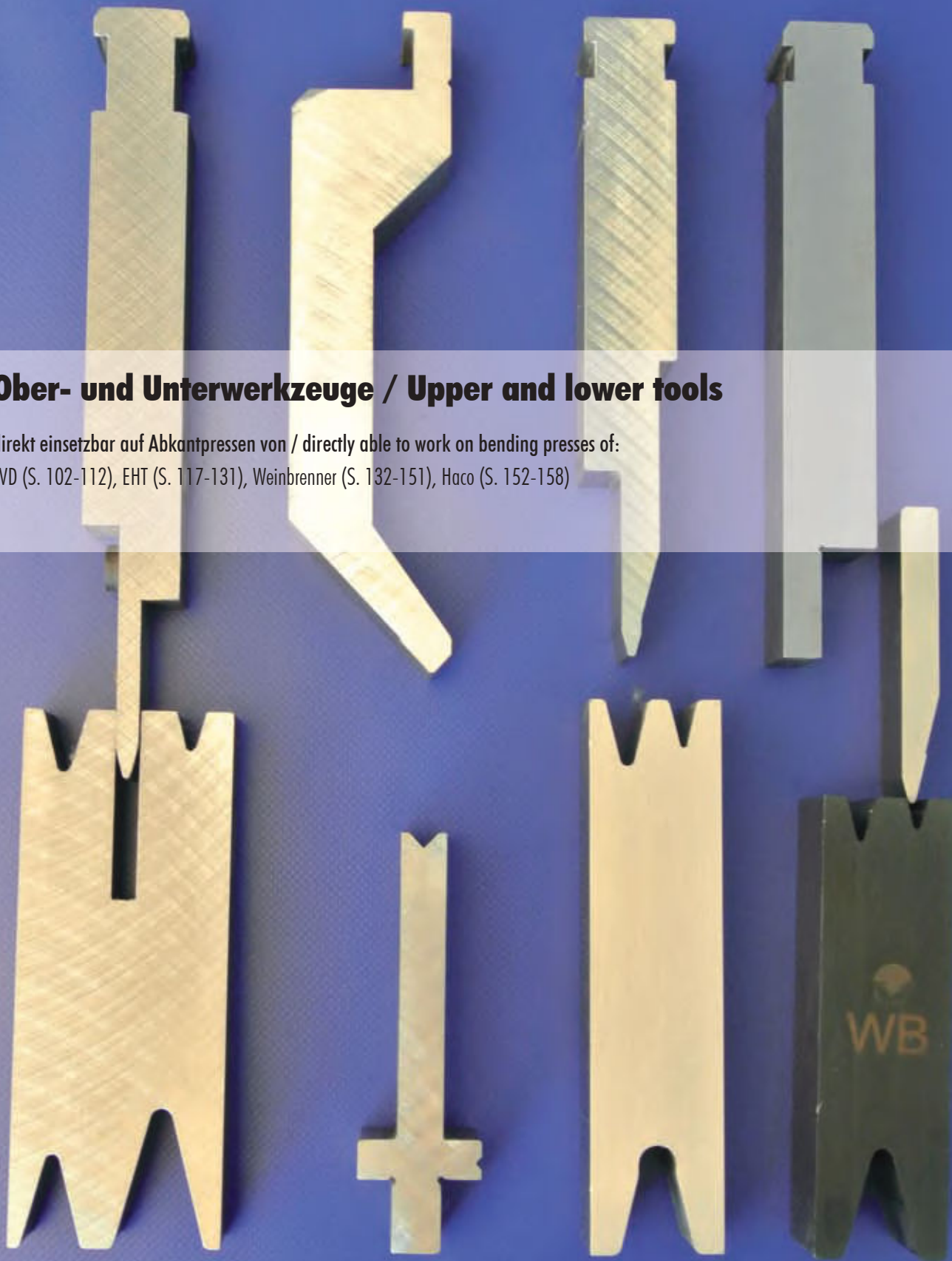

Red Line L

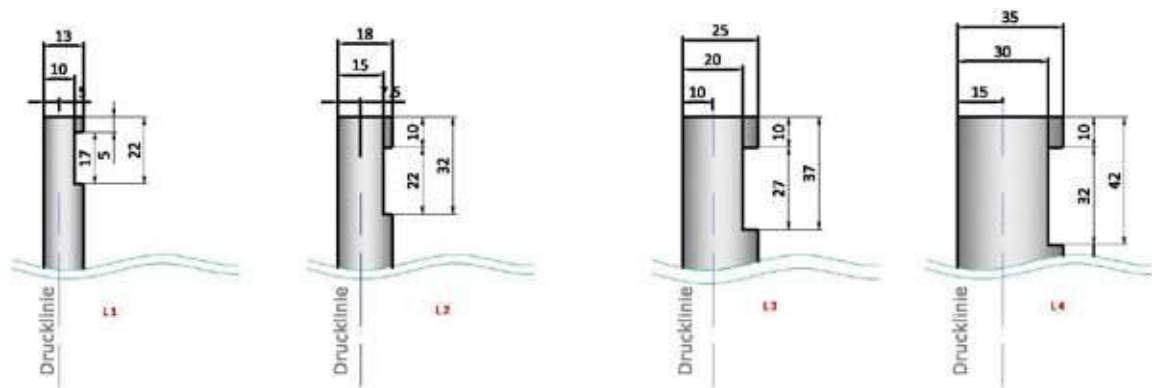

direkt einsetzbar auf Abkantpressen von:
LVD

directly able to work on bending presses of:
LVD

Material:

Westermann24 nutzt die vielfältigen Möglichkeiten der Werkstoffkunde, um Ihnen bestmögliche Qualität zu garantieren.

Verwendete Werkstoffe sind:

- I: C45
- II: C45, vergütet auf 800-850N/mm²
- III: 42CrMo4, vergütet auf 950-1050N/mm²
- Werkzeuge auf Anfrage: 1.2312, vergütet auf 1000-1200N/mm²

Ausführung:

Alle Biegeradien sind geschliffen und gehärtet

Werkzeuflängen:

Die Werkzeuflängen sind bei den Artikelnummern angegeben.
Artikelnummern ohne Längenangabe sind auf Anfrage.

sektionierte Werkzeugsätze:

Oberwerkzeuge:
OW 550mm sektioniert in : 25,25,30,35,40,45,50,100, 100 Horn links, 100 Horn rechts

Belastbarkeit:

Die Belastbarkeit der Werkzeuge ist bei den Artikelnummern angegeben.
Werkzeuge die höher belastet werden sollen, können auf Anfrage konstruiert werden.
(siehe Seite 161)

material:

Westermann24 uses the many possibilities of the material engineering, to guarantee best quality.

used materials are:

- I: C45
- II: C45, tempered to 800-850N/mm²
- III: 42CrMo4, tempered to 950-1050N/mm²
- tools on request: 1.2312, tempered to 1000-1200N/mm²

design:

All radii are grinded and hardened

length of the tool:

The tool length are posted with the art-no.
Article- number without length- determination are available on request.

tool sets divided into sections:

Upper tool:
OW 550mm sectioned in : 25,25,30,35,40,45,50,100, 100 horn left, 100 horn right

loading capacity:

The loading capacity of the tools is specified by the article number.
Tools which will also be loaded more heavily, can be designed by agreement with the relevant application engineering. (see Page 161)

1.09.030

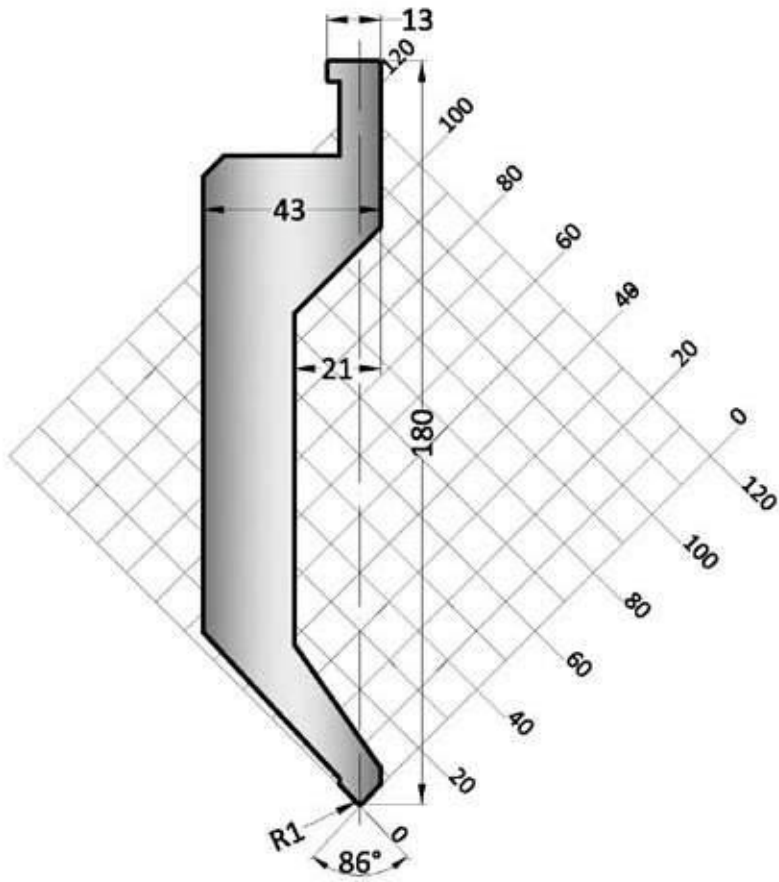

86°

1.09.050

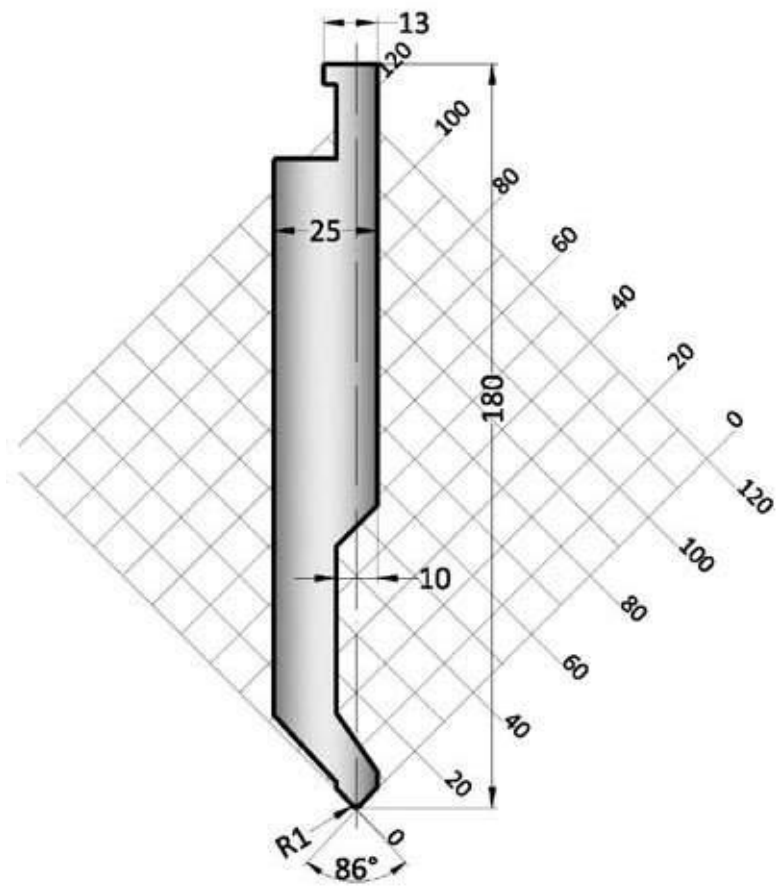

Westermann24 entwickelt für Sie die richtige Werkzeugform für Ihr Produkt. (S. 161)

86°

Red Line

1.09.061



Red Line

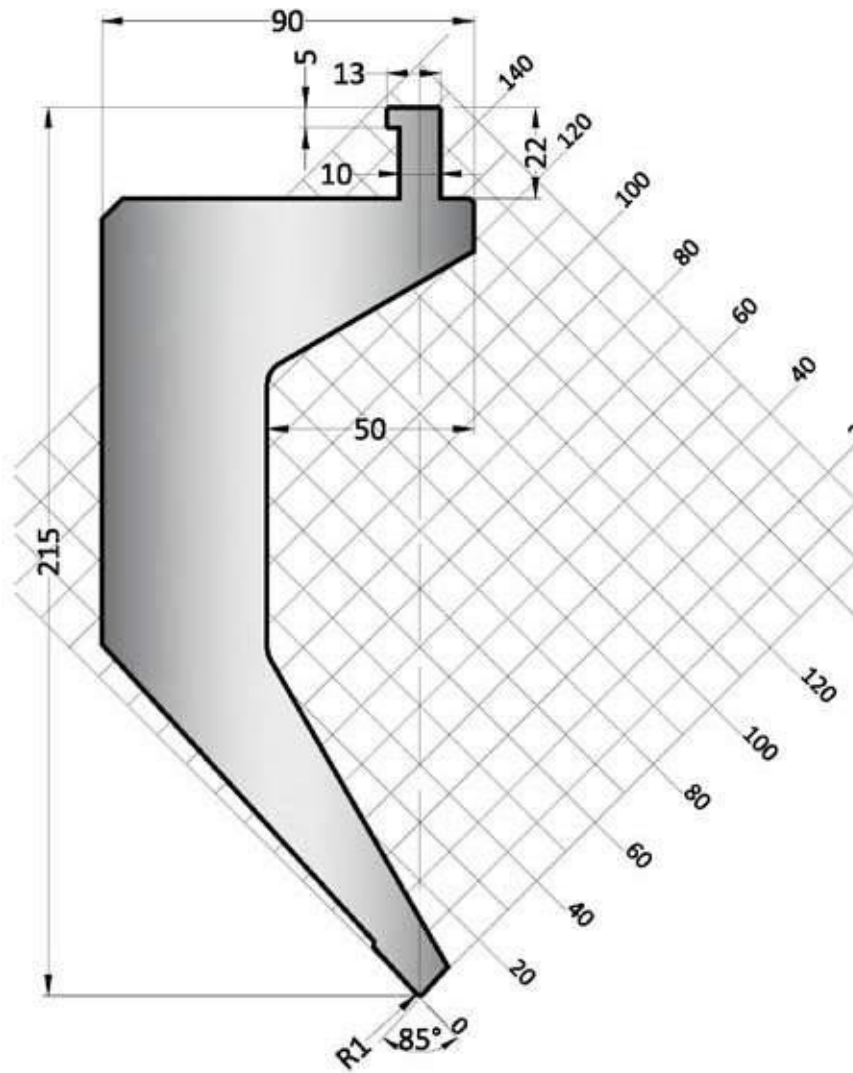

Westermann24 entwickelt für Sie die richtige Werkzeugform für Ihr Produkt. (S. 161)



85°

1.09.062

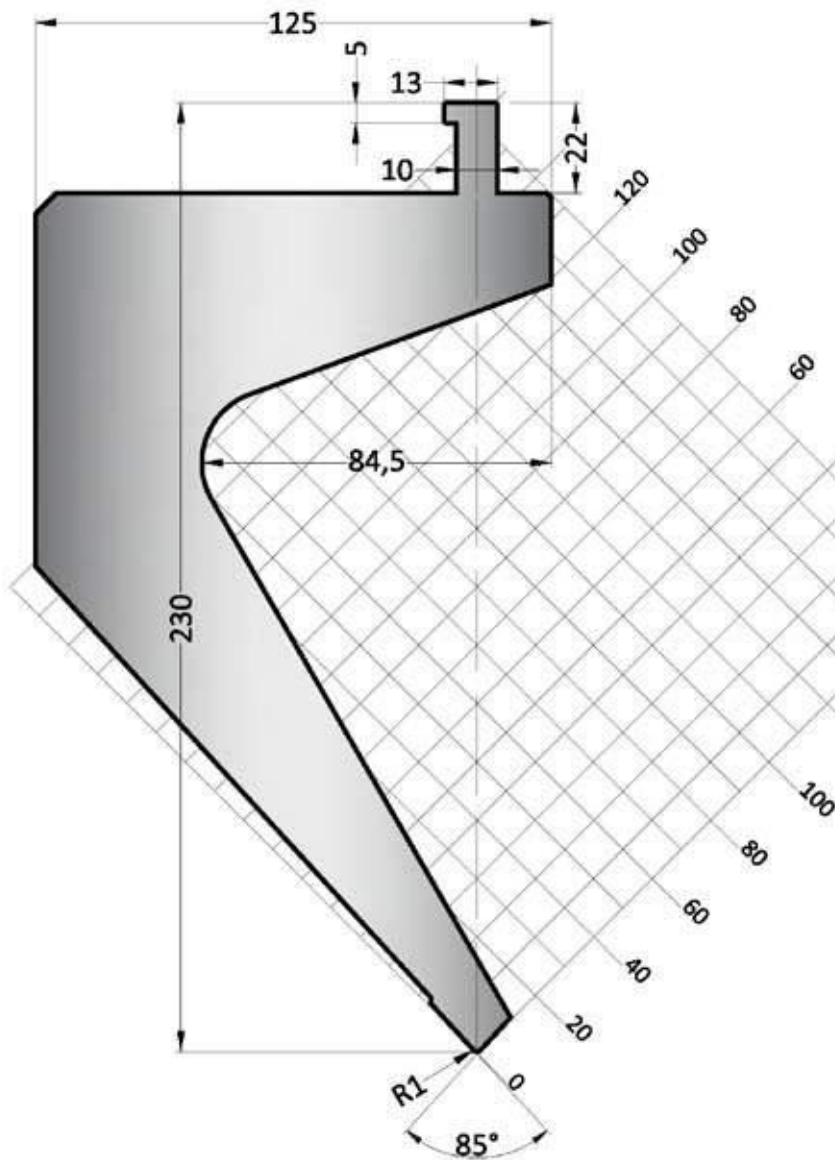

Red Line

86°

1.09.010

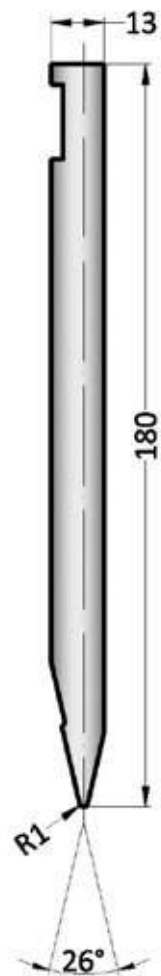

26°

Red Line

Montagebeispiel - Assembly Scheme

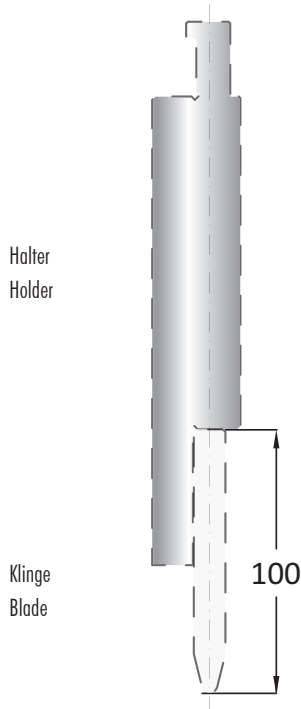

	H	Mt
16.070	138.00	III

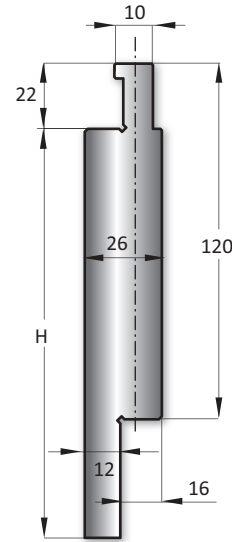
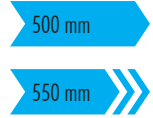

Red Line

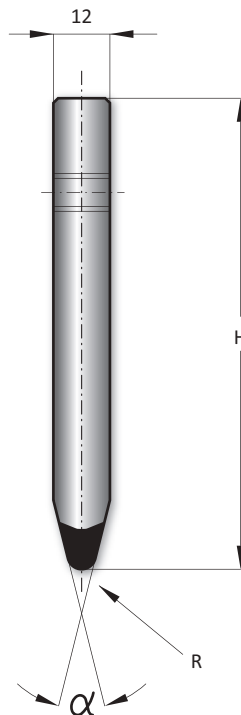
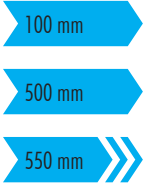

	α	R	H	T/mt	Mt
15.776	86°	1.00	100	100	III
15.774	84°	1.00	100	100	III
15.769	28°	6.00	100	100	III
15.768	28°	5.00	100	100	III
15.767	28°	4.00	100	100	III
15.766	28°	3.00	100	100	III
15.765	28°	2.00	100	100	III
15.763	28°	1.00	100	100	III
15.761	28°	0.50	100	100	III

86°

84°

28°

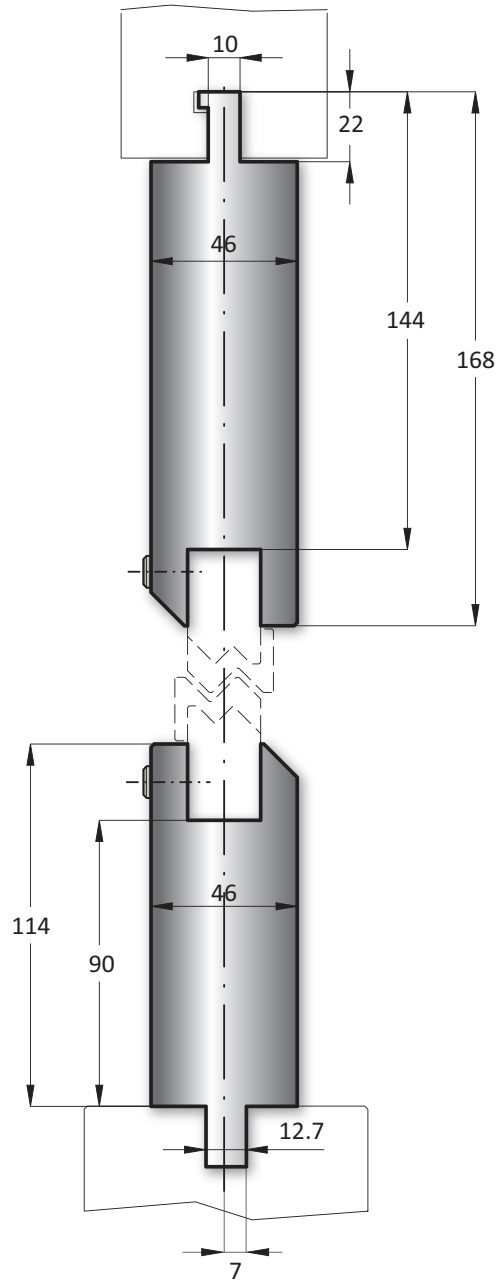

	T/mt	Mt
16.050	100	I

415 mm

835 mm

Montagebeispiel - Assembly Scheme

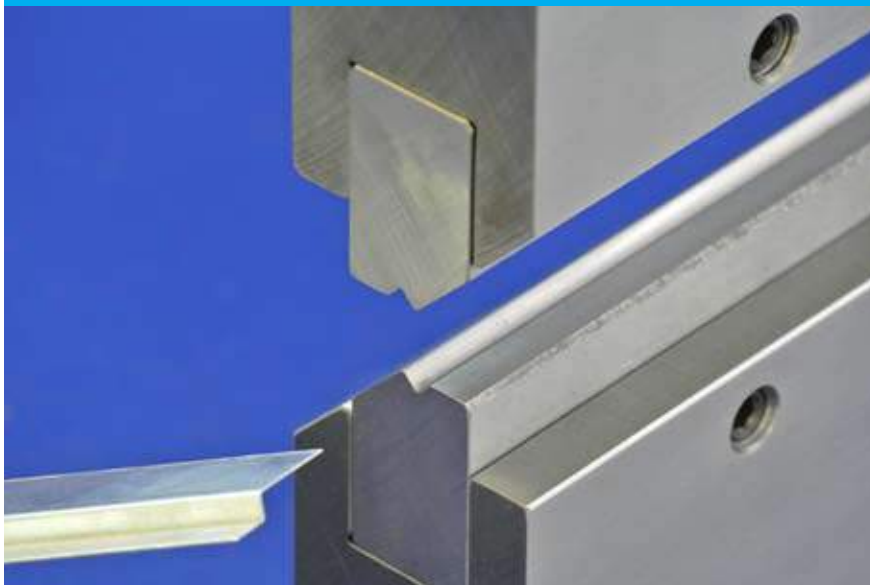

415 mm

835 mm

	Z	α	T/mt	Mt
40.510	1.00	160°	100	I
40.515	1.50	160°	100	I
40.520	2.00	150°	100	I
40.525	2.50	140°	100	I

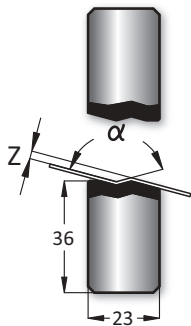

160°

150°

140°

415 mm

835 mm

	Z	α	T/mt	Mt
40.511	1.00	90°	100	I
40.516	1.50	90°	100	I
40.521	2.00	90°	100	I
40.526	2.50	90°	100	I
40.530	3.00	90°	100	I
40.535	3.50	90°	100	I
40.540	4.00	90°	100	I
40.545	4.50	90°	100	I
40.550	5.00	90°	100	I
40.555	5.50	90°	100	I
40.560	6.00	90°	100	I
40.565	6.50	90°	100	I
40.570	7.00	90°	100	I
40.575	7.50	90°	100	I
40.580	8.00	90°	100	I

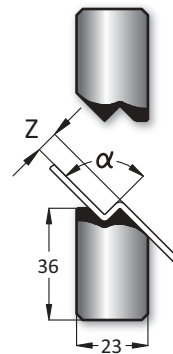

90°

415 mm

835 mm

	Z	α	T/mt	Mt
40.590	9.00	90°	100	I
40.610	10.00	90°	100	I
40.611	11.00	90°	100	I
40.612	12.00	90°	100	I

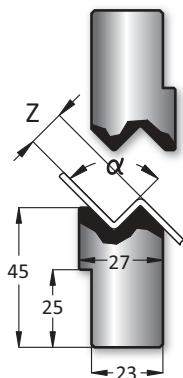

90°

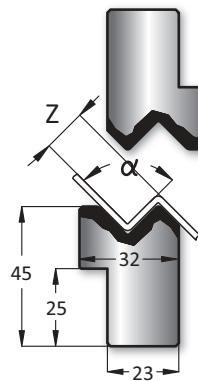

415 mm

835 mm

90°

	Z	α	T/mt	Mt
40.613	13.00	90°	100	I
40.614	14.00	90°	100	I
40.615	15.00	90°	100	I



	Z	α	T/mt	Mt
40.500				I

415 mm

835 mm

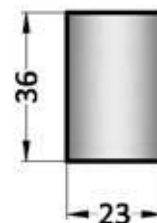

90°

	H	T/mt	Mt
16.010	170.00	80	I

412 mm

830 mm

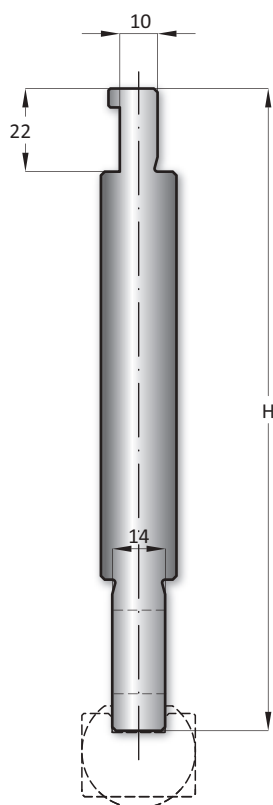

Red Line

415 mm

835 mm

	R	A
10.300	7.00	11.50
10.301	7.50	11.50
10.302	8.00	13.00
10.303	9.00	16.00
10.304	10.00	16.00
10.305	11.00	16.00
10.306	11.50	19.00
10.307	12.00	20.00

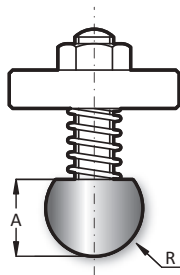

415 mm

835 mm

	R	A	B
10.308	12.50	16.00	21.00
10.309	13.00	17.00	23.00
10.310	14.00	19.00	25.00
10.311	15.00	20.00	27.00
10.312	16.00	21.00	28.00
10.313	17.00	21.50	31.50
10.314	17.50	22.00	32.00
10.315	19.00	25.00	32.00
10.316	20.00	24.00	34.00
10.317	22.50	25.00	33.00
10.318	25.00	29.00	39.00
10.319	27.50	34.00	44.00
10.320	30.00	34.00	44.00
10.321	35.00	45.00	55.00
10.322	40.00	45.00	55.00
10.323	45.00	50.00	60.00
10.324	50.00	54.00	64.00

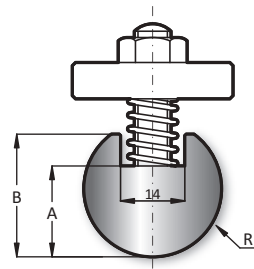

415 mm

835 mm

	A	B
10.325	17.00	22.00

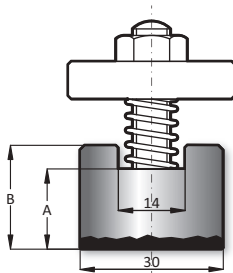

Westermann24 liefert
Ihnen Lösungen für
Halter mit Einsatz.
(S. 163)

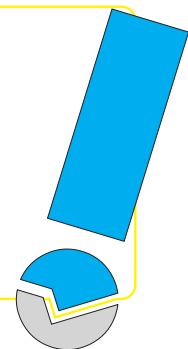

Red Line L

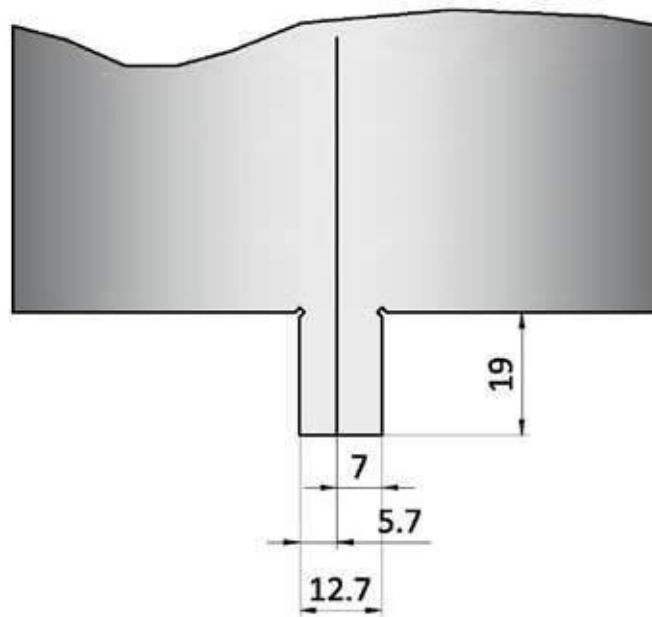

direkt einsetzbar auf Abkantpressen von:
LVD

directly able to work on bending presses of:
LVD

Material:

Westermann24 nutzt die vielfältigen Möglichkeiten der Werkstoffkunde, um Ihnen bestmögliche Qualität zu garantieren.

Verwendete Werkstoffe sind:

- I: C45
- II: C45, vergütet auf 800-850N/mm²
- III: 42CrMo4, vergütet auf 950-1050N/mm²
- Werkzeuge auf Anfrage: 1.2312, vergütet auf 1000-1200N/mm²

Ausführung:

Alle Biegeradien sind geschliffen und gehärtet

Werkzeuglängen:

Die Werkzeuglängen sind bei den Artikelnummern angegeben.
Artikelnummern ohne Längenangabe sind auf Anfrage.

sektionierte Werkzeugsätze:

Unterwerkzeuge:
UW 550mm sektioniert in : 25,25,30,35,40,45,50,100,200mm

Belastbarkeit:

Die Belastbarkeit der Werkzeuge ist bei den Artikelnummern angegeben.
Werkzeuge die höher belastet werden sollen, können auf Anfrage konstruiert werden.
(siehe Seite 161)

material:

Westermann24 uses the many possibilities of the material engineering, to guarantee best quality.

used materials are:

- I: C45
- II: C45, tempered to 800-850N/mm²
- III: 42CrMo4, tempered to 950-1050N/mm²
- tools on request: 1.2312, tempered to 1000-1200N/mm²

design:

All radii are grinded and hardened

length of the tool:

The tool length are posted with the art-no.
Article- number without length- determination are available on request.

tool sets divided into sections:

Lower tool:
UW 550mm sectioned in : 25,25,30,35,40,45,50,100,200mm

loading capacity:

The loading capacity of the tools is specified by the article number.
Tools which will also be loaded more heavily, can be designed by agreement with the relevant application engineering. (see Page 161)

508 mm
550 mm

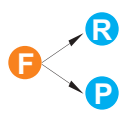
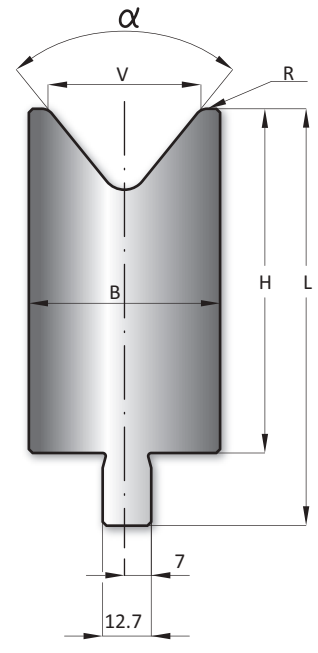
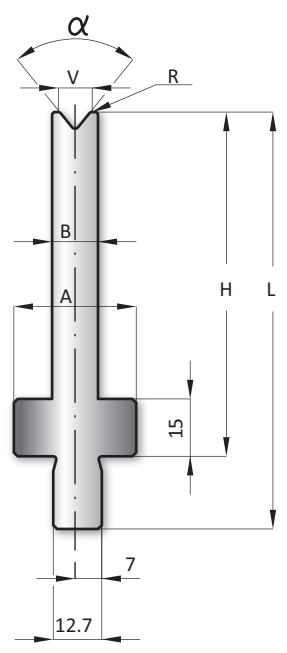
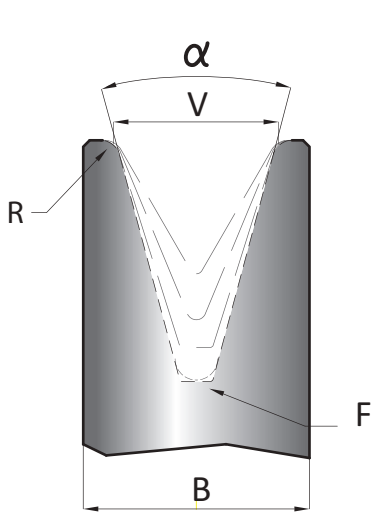

78°	V	B	A	R	H	L	T/mt	Mt
26.706	6	12	32	0,8	90	109	40	I
26.708	8	12	32	1,0	90	109	40	I
26.710	10	14	32	1,2	90	109	50	I
26.712	12	18	32	1,5	90	109	60	I
26.716	16	25	32	2,0	90	109	80	I
26.720	20	32	/	2,5	90	109	80	I
26.724	24	32	/	3,0	90	109	100	I
26.730	30	40	/	3,0	90	109	100	I
26.740	40	50	/	3,5	90	109	100	I
26.750	50	70	/	4,0	90	109	100	I
26.760	60	70	/	5,0	90	109	100	I
26.780	80	95	/	6,0	90	109	100	I
26.794	100	120	/	8,0	90	109	100	I
26.797	120	140	/	10,0	130	149	100	I

60°	V	H
2.09.224	16	90
2.09.225	20	90
2.09.226	24	90
2.09.227	30	90
2.09.228	35	90
2.09.229	40	90
2.09.230	50	90
2.09.231	60	90
2.09.232	80	90
2.09.233	100	110
2.09.234	120	130



30°	V	B	A	R	H	L	T/mt	Mt
26.306	6	16	32	0,8	90	109	40	III
26.308	8	18	32	1,0	90	109	35	III
26.310	10	25	32	1,2	90	109	40	III
26.321	12	25	32	1,5	90	109	40	III
26.316	16	32	/	2,0	90	109	50	III
26.320	20	40	/	2,5	90	109	60	III
26.324	24	45	/	3,0	90	109	60	III
2.09.221	30							
2.09.222	35							
2.09.223	40							

Legende - Legend	Technik - technique
F = Nutgrund - ground of the groove	
R = radius	
P = flach - flat	

78°
60°
30°

Red Line

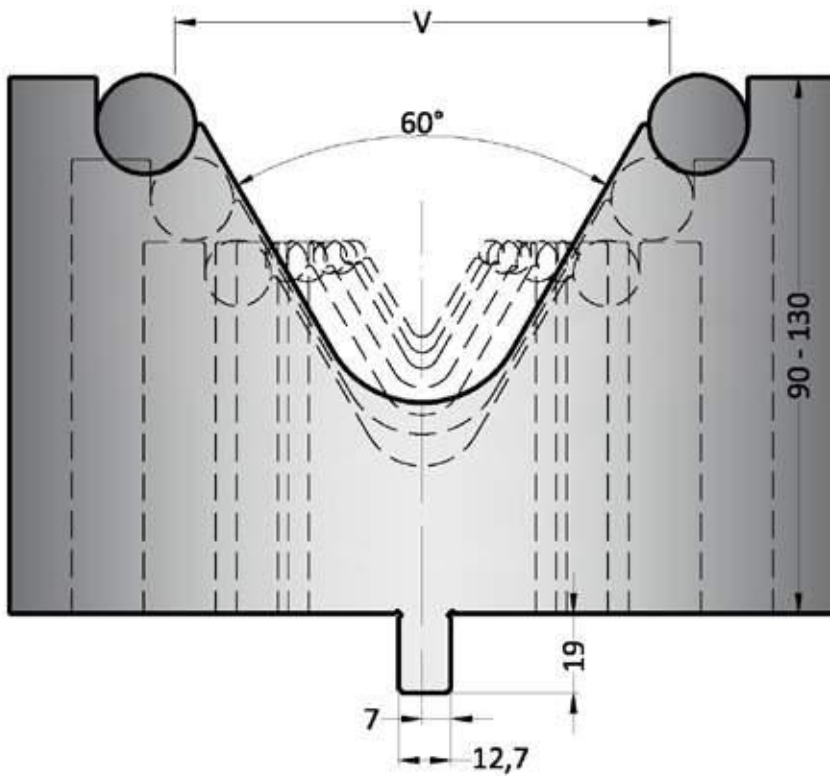

Westermann-LVD - mit Einlaufwellen 60°

	V	α	H
2.24.011	30	60°	99.00
2.24.012	35	60°	99.00
2.24.013	40	60°	99.00
2.24.014	50	60°	99.00
2.24.015	60	60°	99.00
2.24.016	80	60°	99.00
2.24.017	100	60°	110.00
2.24.018	120	60°	130.00



Westermann 24 liefert Ihnen Matrizen mit Welleneinsatz. (S. 162)

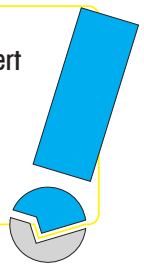

60°

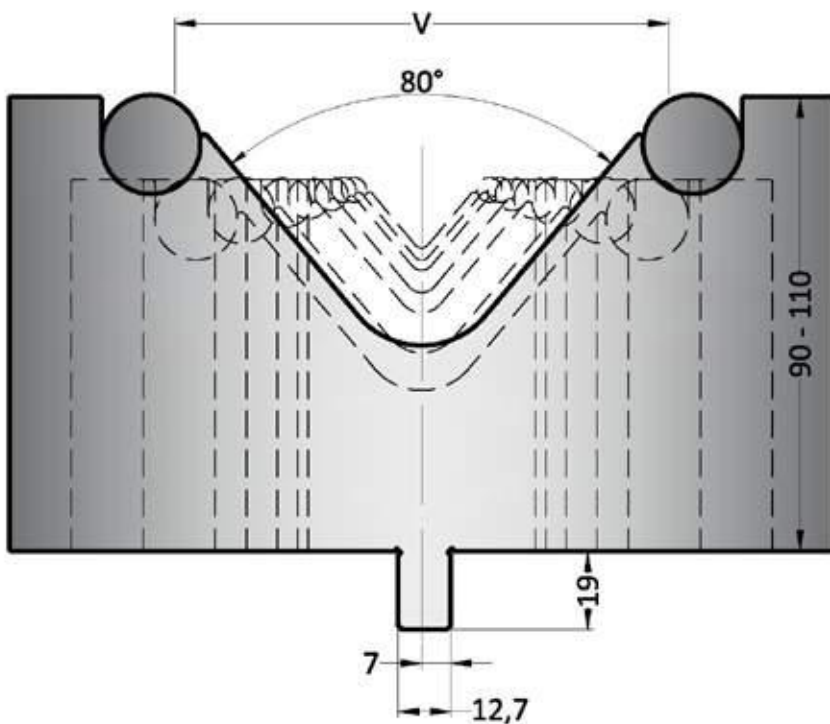

Westermann-LVD - mit Einlaufwellen 80°

	V	α	H
2.24.011	30	80°	90.00
2.24.012	35	80°	90.00
2.24.013	50	80°	90.00
2.24.014	60	80°	90.00
2.24.015	80	80°	90.00
2.24.016	100	80°	90.00
2.24.017	120	80°	110.00



80°

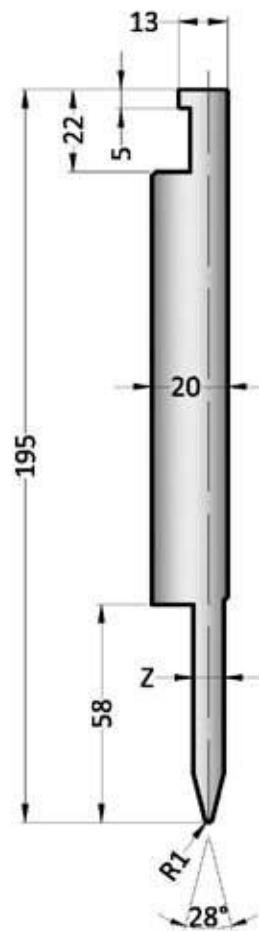

	α	R	Z	H
1.09.063	28°	1.00	8	195.00
1.09.064	28°	1.00	10	195.00
1.09.065	28°	1.00	12	195.00



28°

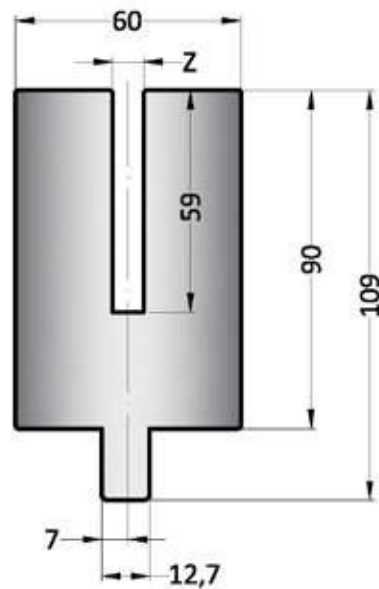

	Z	H
2.09.246	8,2	90.00
2.09.247	10,2	90.00
2.09.248	12,2	90.00



Red Line

Red Line

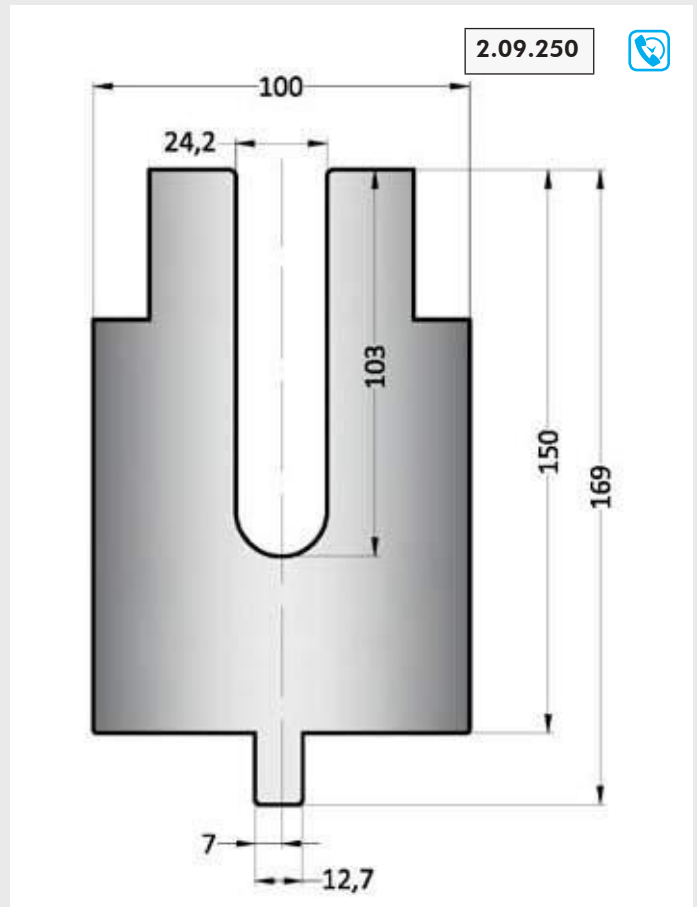
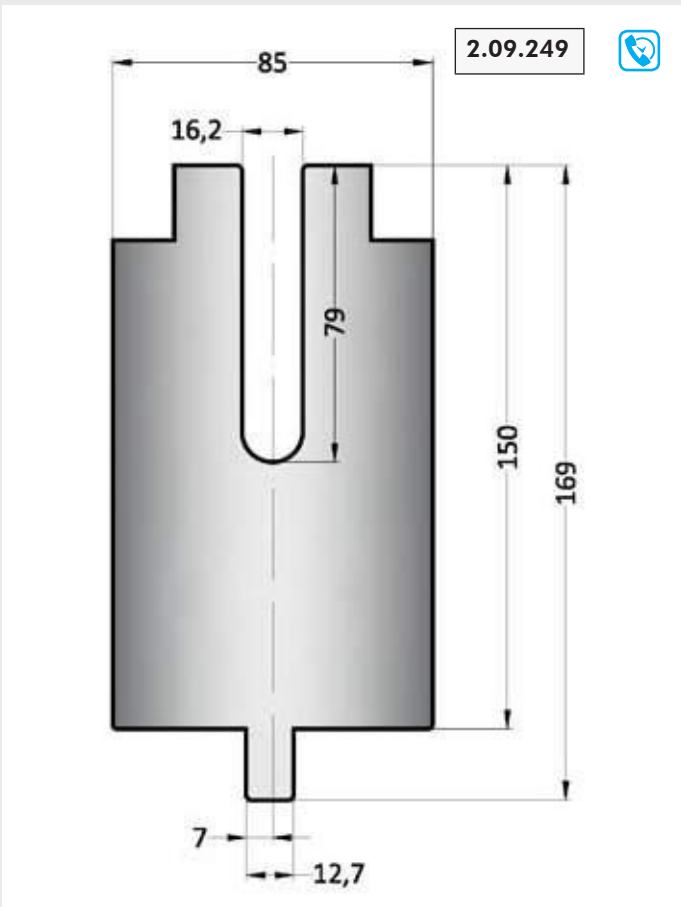
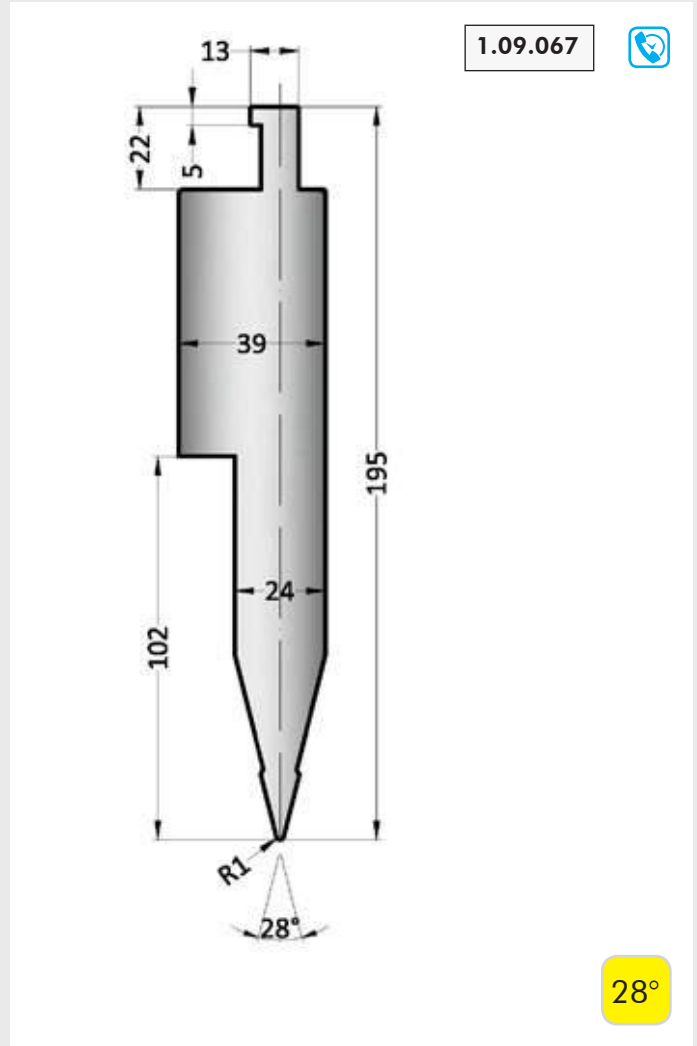
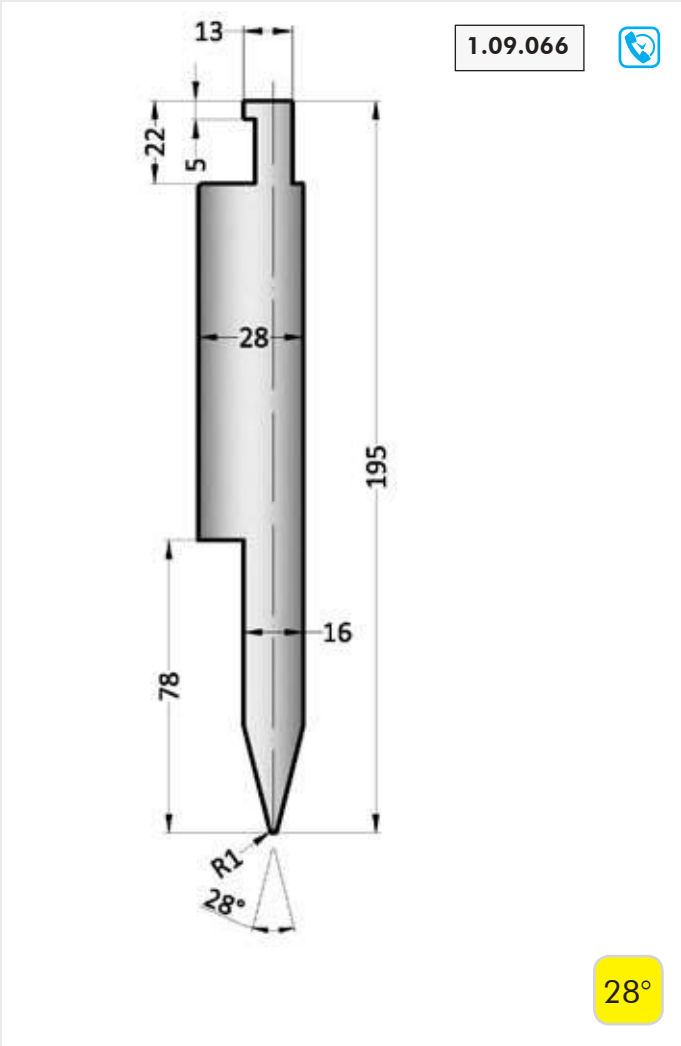

Red Line E

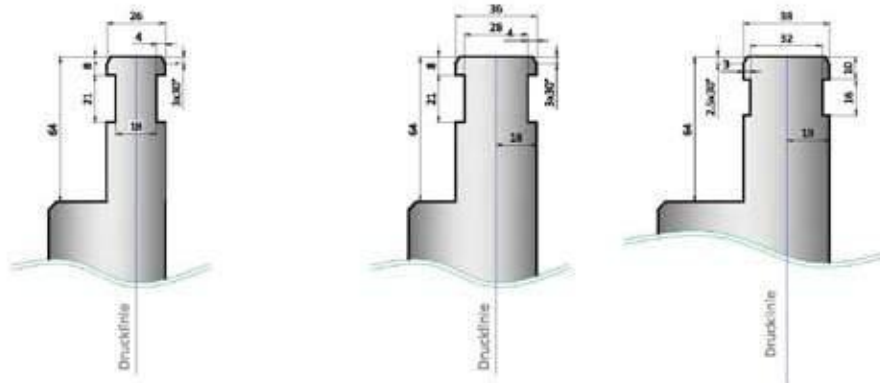

direkt einsetzbar auf Abkantpressen von:
EHT

Material:

Westermann24 nutzt die vielfältigen Möglichkeiten der Werkstoffkunde, um Ihnen bestmögliche Qualität zu garantieren.

Verwendete Werkstoffe sind:

- I: C45
- II: C45, vergütet auf 800-850N/mm²
- III: 42CrMo4, vergütet auf 950-1050N/mm²
- Werkzeuge auf Anfrage: 1.2312, vergütet auf 1000-1200N/mm²

Ausführung:

Alle Biegeradien sind geschliffen und gehärtet

Werkzeuglängen:

Die Werkzeuglängen sind bei den Artikelnummern angegeben.
Artikelnummern ohne Längenangabe sind auf Anfrage.

sektionierte Werkzeugsätze:

Oberwerkzeuge:
OW 1050mm sektioniert in : 45,50,55,60,65,70,75,80,85,90,175,100 Horn links, 100 Horn rechts

Belastbarkeit:

Die Belastbarkeit der Werkzeuge ist bei den Artikelnummern angegeben.
Werkzeuge die höher belastet werden sollen, können auf Anfrage konstruiert werden.
(siehe Seite 161)

directly able to work on bending presses of:
EHT

material:

Westermann24 uses the many possibilities of the material engineering, to guarantee best quality.

used materials are:

- I: C45
- II: C45, tempered to 800-850N/mm²
- III: 42CrMo4, tempered to 950-1050N/mm²
- tools on request: 1.2312, tempered to 1000-1200N/mm²

design:

All radii are grinded and hardened

length of the tool:

The tool length are posted with the art-no.
Article- number without length- determination are available on request.

tool sets divided into sections:

Upper tool:
OW 1050mm sectioned in : 45,50,55,60,65,70,75,80,85,90,175,100 horn left, 100 horn right

loading capacity:

The loading capacity of the tools is specified by the article number.
Tools which will also be loaded more heavily, can be designed by agreement with the relevant application engineering. (see Page 161)

Red Line

1.05.100 

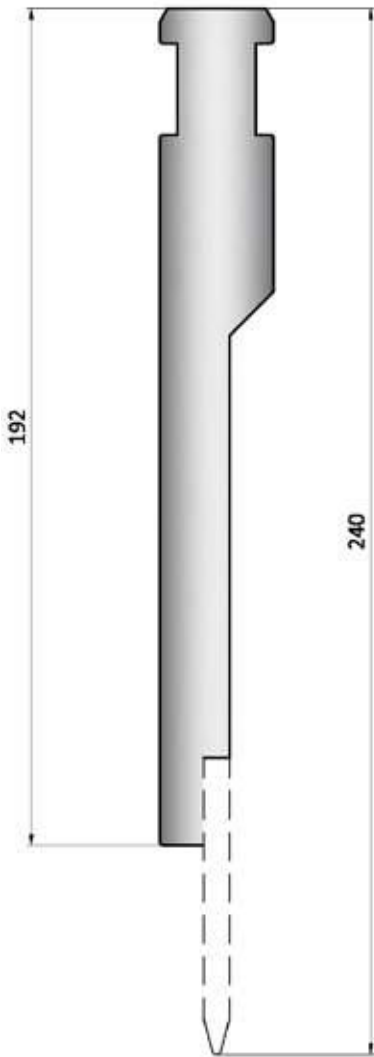

192

240

Westermann24 entwickelt für Sie die richtige Werkzeugform für Ihr Produkt. (S. 161) 

1.05.132 

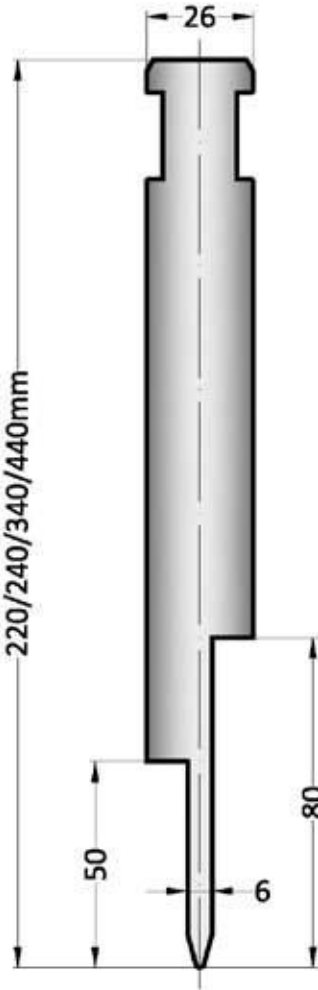

26

220/240/340/440mm

50

80

6

Form einteilig

30° 

1.05.120 

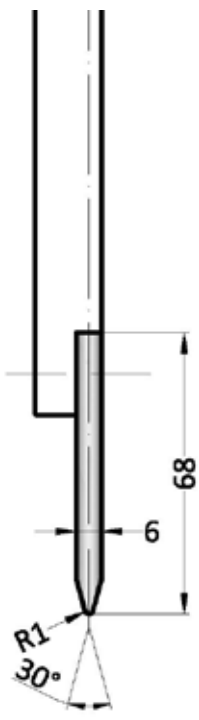

68

6

R1

30°

30° 

1.05.010

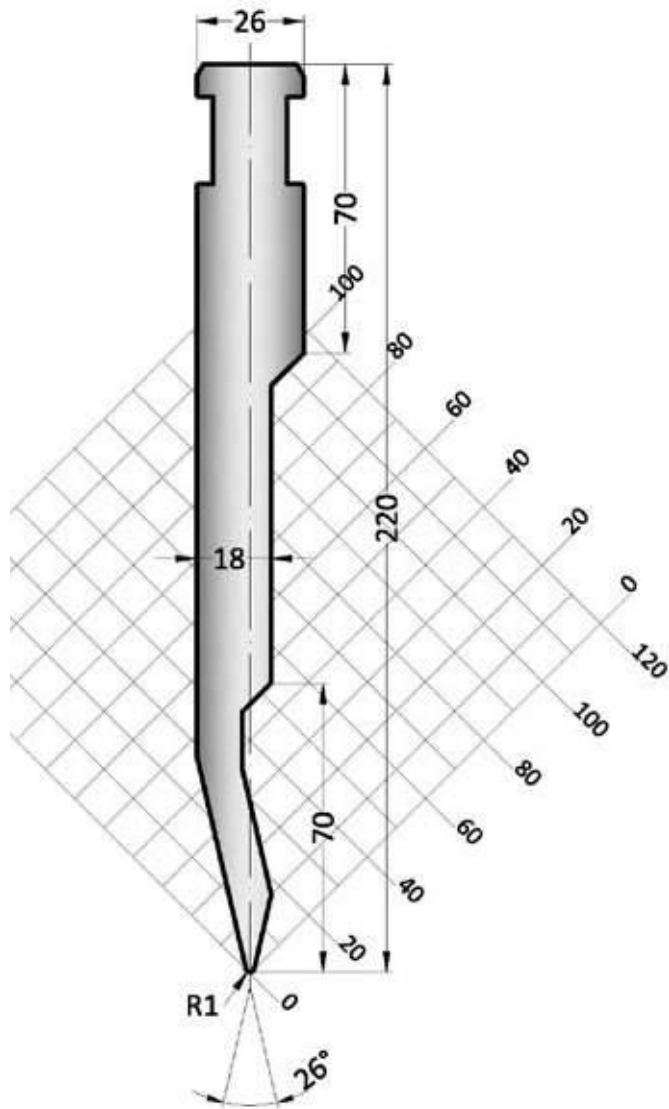

26°

1.05.070

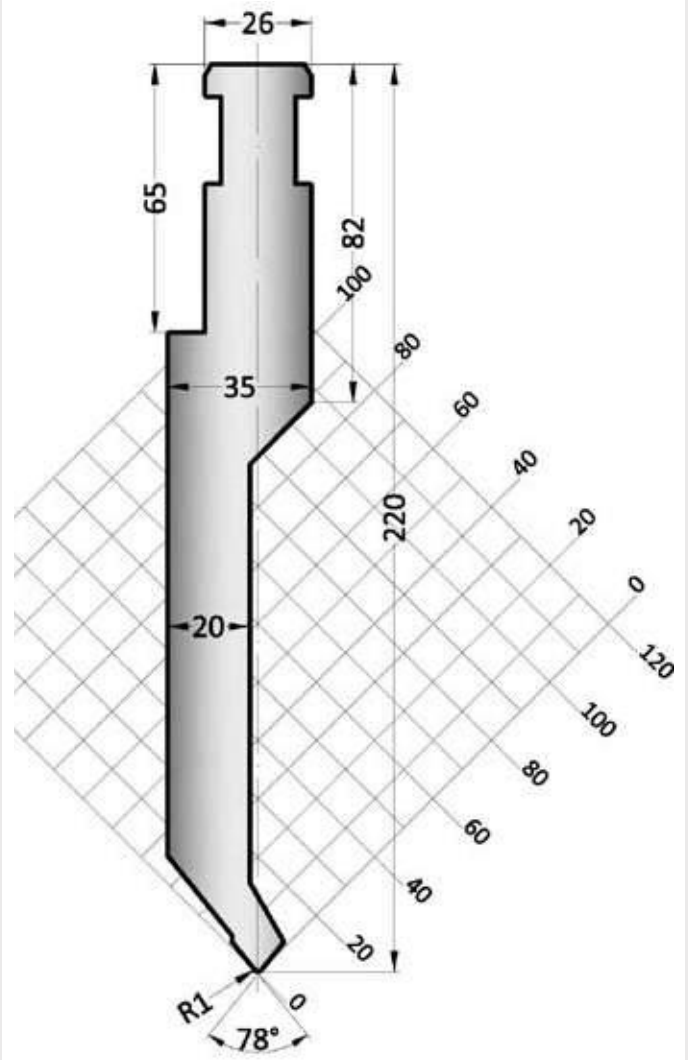

78°

Red Line

Red Line

1.05.040

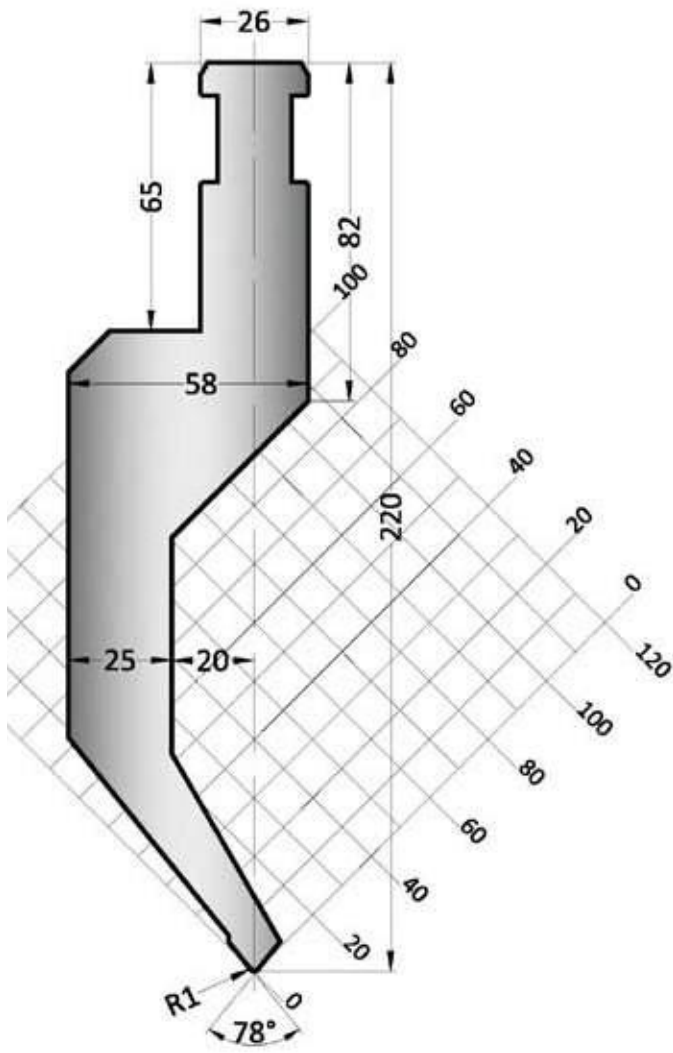

78°

1.05.133

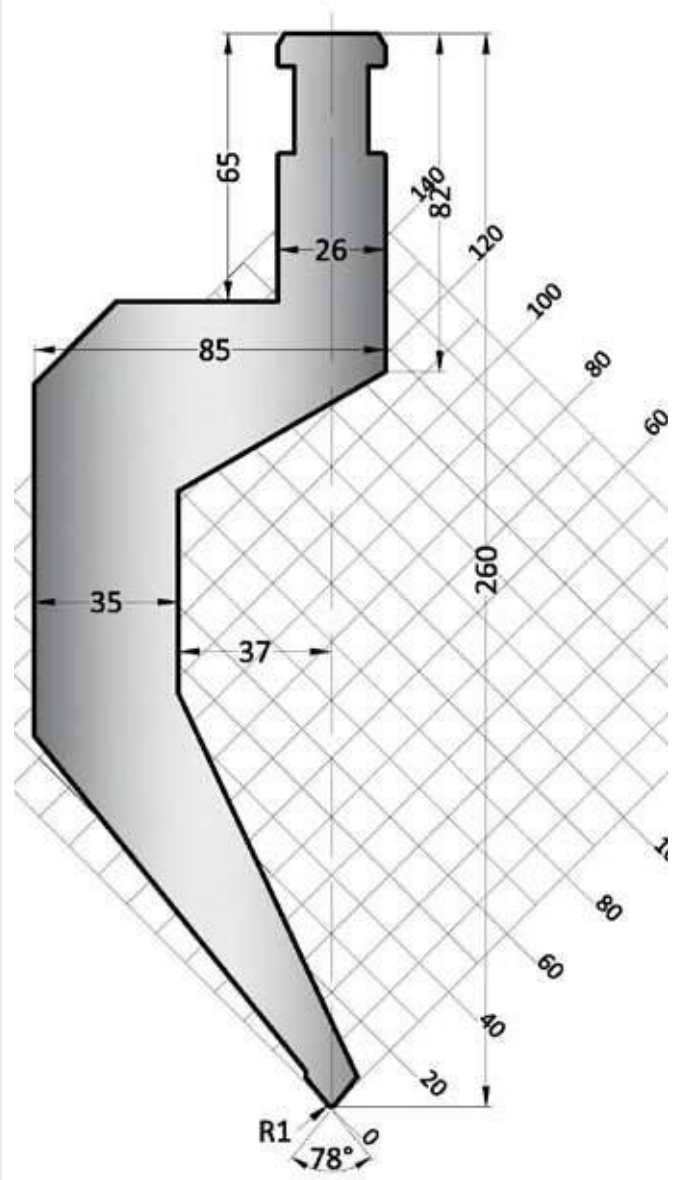

78°

Montagebeispiel - Assembly Scheme

Halter
Holder

Klinge
Blade

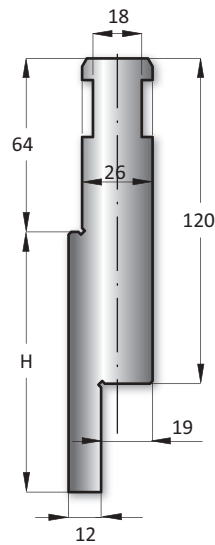
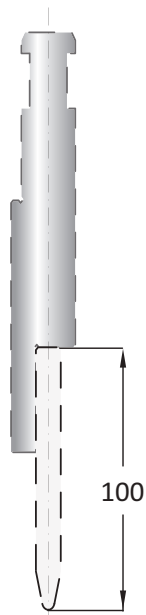

	H	Mt
17.070	78.00	I

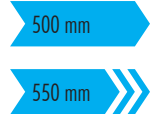

Red Line

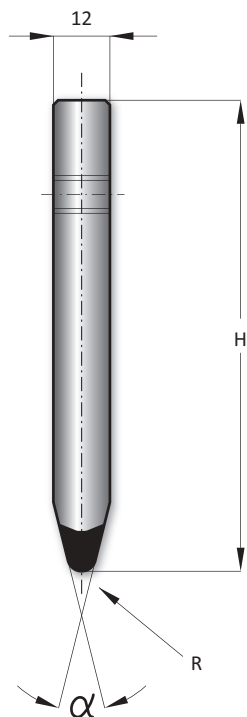
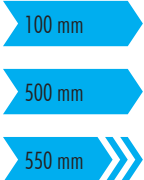

	α	R	H	T/mt	Mt
15.776	86°	1.00	100	100	III
15.774	84°	1.00	100	100	III
15.769	28°	6.00	100	100	III
15.768	28°	5.00	100	100	III
15.767	28°	4.00	100	100	III
15.766	28°	3.00	100	100	III
15.765	28°	2.00	100	100	III
15.763	28°	1.00	100	100	III
15.761	28°	0.50	100	100	III

86°

84°

28°

	T/mt	Mt
17.050	100	I

415 mm

835 mm

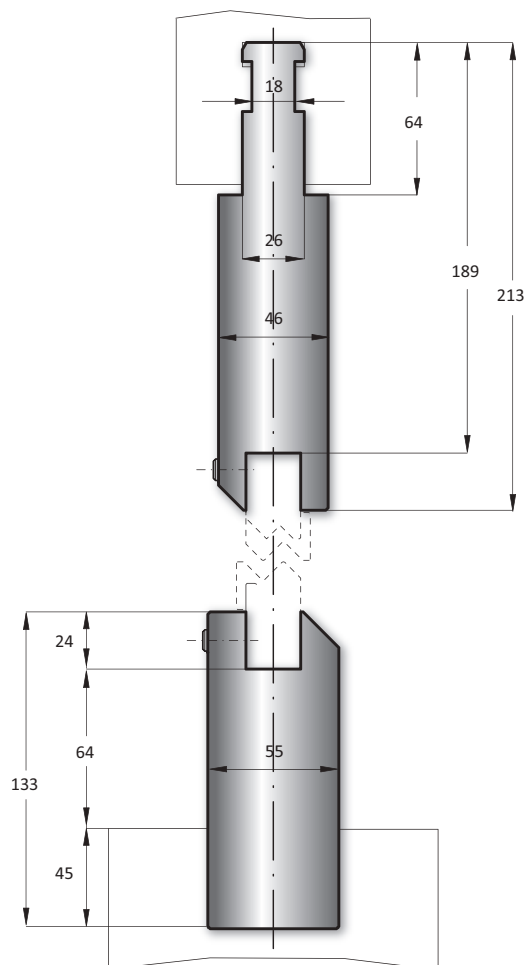

Montagebeispiel - Assembly Scheme

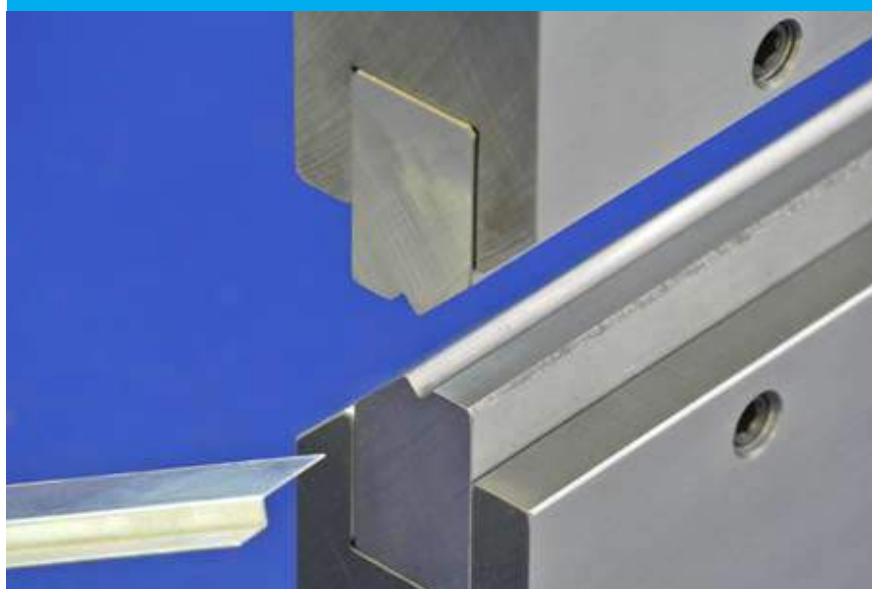

415 mm

835 mm

	Z	α	T/mt	Mt
40.510	1.00	160°	100	I
40.515	1.50	160°	100	I
40.520	2.00	150°	100	I
40.525	2.50	140°	100	I

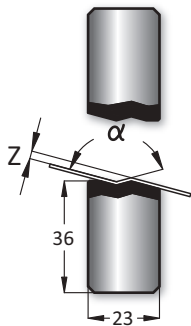

160°

150°

140°

415 mm

835 mm

	Z	α	T/mt	Mt
40.511	1.00	90°	100	I
40.516	1.50	90°	100	I
40.521	2.00	90°	100	I
40.526	2.50	90°	100	I
40.530	3.00	90°	100	I
40.535	3.50	90°	100	I
40.540	4.00	90°	100	I
40.545	4.50	90°	100	I
40.550	5.00	90°	100	I
40.555	5.50	90°	100	I
40.560	6.00	90°	100	I
40.565	6.50	90°	100	I
40.570	7.00	90°	100	I
40.575	7.50	90°	100	I
40.580	8.00	90°	100	I

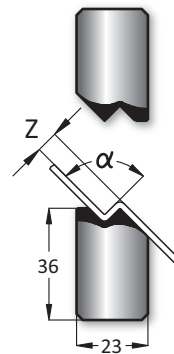

90°

415 mm

835 mm

	Z	α	T/mt	Mt
40.590	9.00	90°	100	I
40.610	10.00	90°	100	I
40.611	11.00	90°	100	I
40.612	12.00	90°	100	I

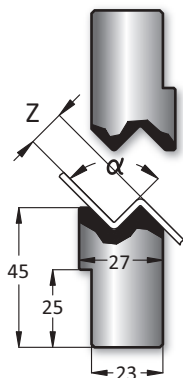

90°

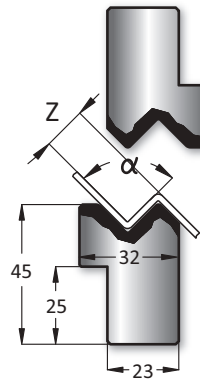

415 mm

835 mm

90°

	Z	α	T/mt	Mt
40.613	13.00	90°	100	I
40.614	14.00	90°	100	I
40.615	15.00	90°	100	I



	Z	α	T/mt	Mt
40.500				I

415 mm

835 mm

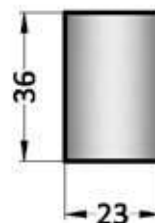

90°

	H	T/mt	Mt
17.010	200.00	80	I

412 mm

830 mm

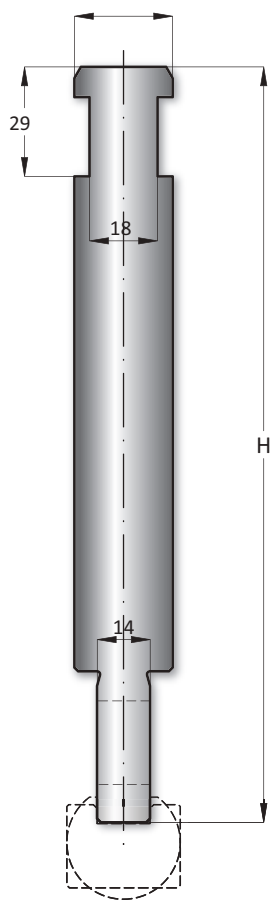

Red Line

415 mm

835 mm

	R	A
10.300	7.00	11.50
10.301	7.50	11.50
10.302	8.00	13.00
10.303	9.00	16.00
10.304	10.00	16.00
10.305	11.00	16.00
10.306	11.50	19.00
10.307	12.00	20.00

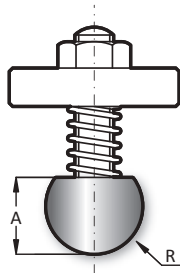

415 mm

835 mm

	R	A	B
10.308	12.50	16.00	21.00
10.309	13.00	17.00	23.00
10.310	14.00	19.00	25.00
10.311	15.00	20.00	27.00
10.312	16.00	21.00	28.00
10.313	17.00	21.50	31.50
10.314	17.50	22.00	32.00
10.315	19.00	25.00	32.00
10.316	20.00	24.00	34.00
10.317	22.50	25.00	33.00
10.318	25.00	29.00	39.00
10.319	27.50	34.00	44.00
10.320	30.00	34.00	44.00
10.321	35.00	45.00	55.00
10.322	40.00	45.00	55.00
10.323	45.00	50.00	60.00
10.324	50.00	54.00	64.00

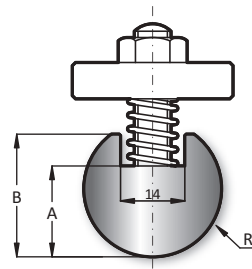

415 mm

835 mm

	A	B
10.325	17.00	22.00

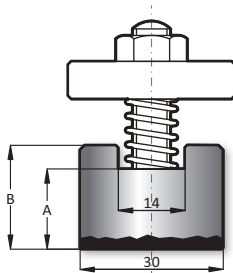

Westermann24 liefert
Ihnen Lösungen für
Halter mit Einsatz.
(S. 163)

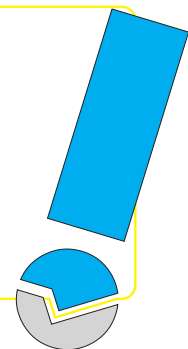

Red Line E



direkt einsetzbar auf Abkantpressen von:
EHT

Material:

Westermann24 nutzt die vielfältigen Möglichkeiten der Werkstoffkunde, um Ihnen bestmögliche Qualität zu garantieren.

Verwendete Werkstoffe sind:

- I: C45
- II: C45, vergütet auf 800-850N/mm²
- III: 42CrMo4, vergütet auf 950-1050N/mm²
- Werkzeuge auf Anfrage: 1.2312, vergütet auf 1000-1200N/mm²

Ausführung:

Alle Biegeradien sind geschliffen und gehärtet

Werkzeuglängen:

Die Werkzeuglängen sind bei den Artikelnummern angegeben.
Artikelnummern ohne Längenangabe sind auf Anfrage.

sektionierte Werkzeugsätze:

Unterwerkzeuge:
UW 1050mm sektioniert in : 45,50,55,60,65,70,75,80,85,90,175,100,100mm

Belastbarkeit:

Die Belastbarkeit der Werkzeuge ist bei den Artikelnummern angegeben.
Werkzeuge die höher belastet werden sollen, können auf Anfrage konstruiert werden.
(siehe Seite 161)

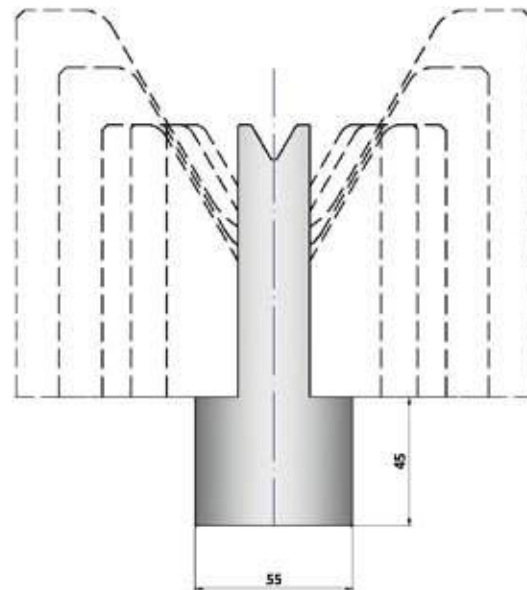

directly able to work on bending presses of:
EHT

material:

Westermann24 uses the many possibilities of the material engineering, to guarantee best quality.

used materials are:

- I: C45
- II: C45, tempered to 800-850N/mm²
- III: 42CrMo4, tempered to 950-1050N/mm²
- tools on request: 1.2312, tempered to 1000-1200N/mm²

design:

All radii are grinded and hardened

length of the tool:

The tool length are posted with the art-no.
Article- number without length- determination are available on request.

tool sets divided into sections:

Lower tool:
UW 1050mm sektioniert in : 45,50,55,60,65,70,75,80,85,90,175,100,100mm

loading capacity:

The loading capacity of the tools is specified by the article number.
Tools which will also be loaded more heavily, can be designed by agreement with the relevant application engineering. (see Page 161)

2.05.009

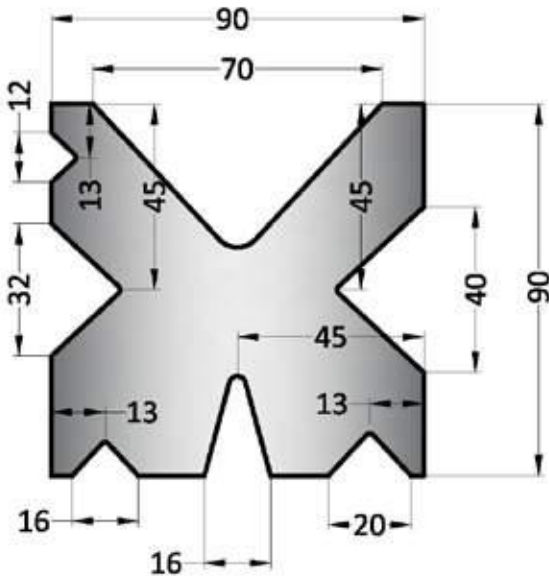

Nicht bemaßte Winkel = 30° / 86°

2.05.010

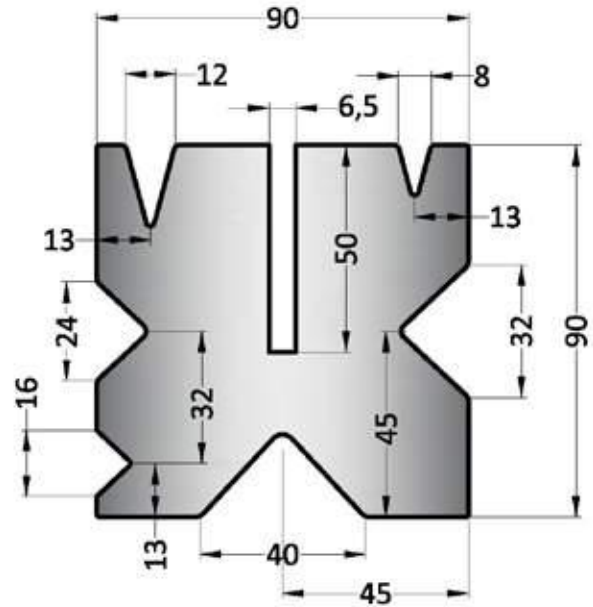

Nicht bemaßte Winkel = 30° / 86°

2.05.180

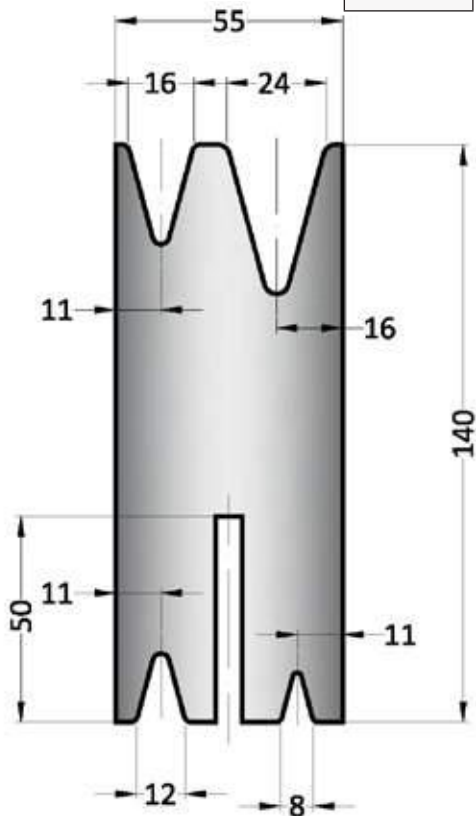

Nicht bemaßte Winkel = 30°

2.05.060

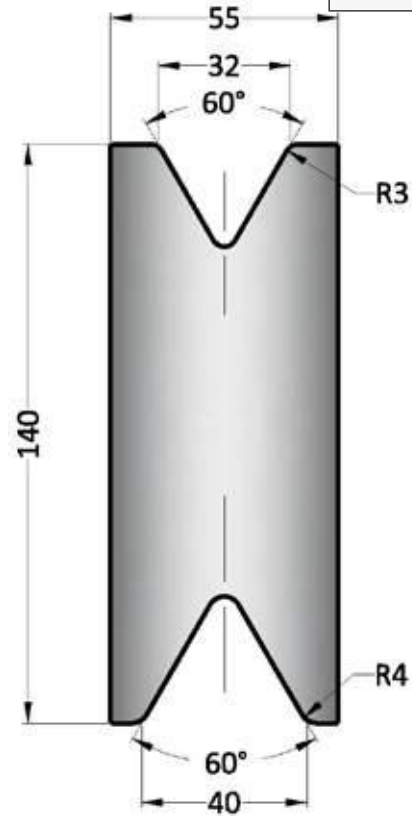

Red Line

2.05.090

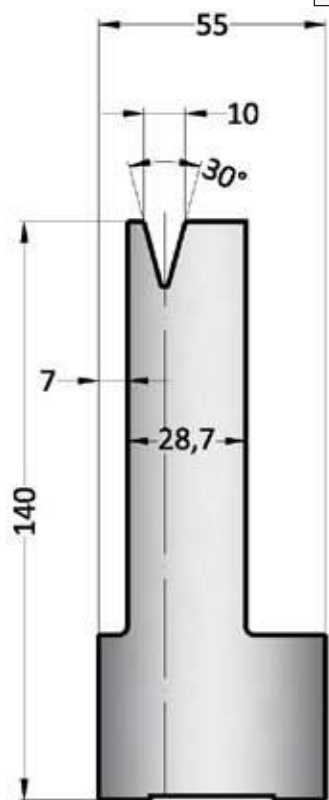

2.05.120

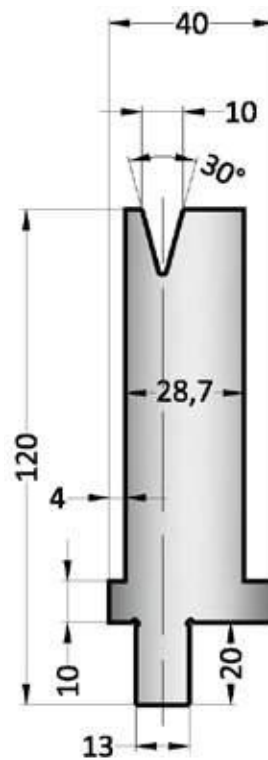

30°	V
2.05.201	30
2.05.202	35
2.05.203	40

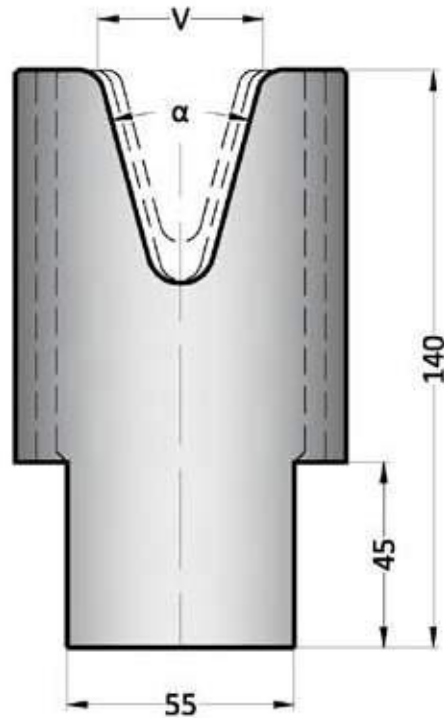

30°

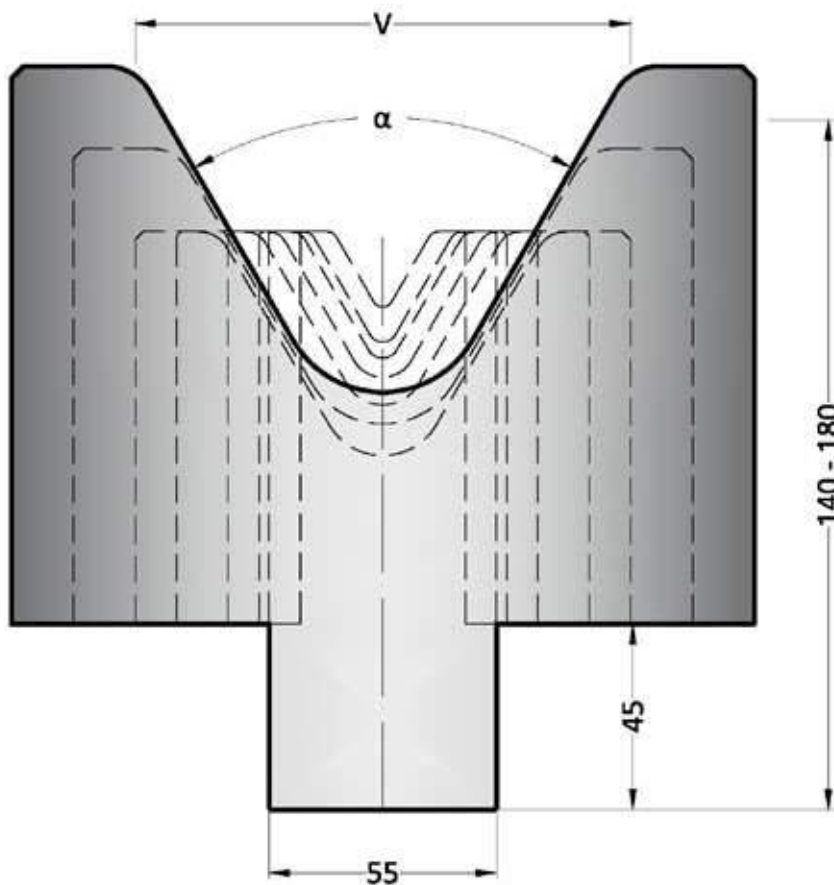

60°	V	H
2.05.204	16	140.00
2.05.205	20	140.00
2.05.206	24	140.00
2.05.207	30	140.00
2.05.208	35	140.00
2.05.209	40	140.00
2.05.210	50	140.00
2.05.211	60	140.00
2.05.212	80	140.00
2.05.213	100	150.00
2.05.214	120	180.00



60°

Red Line

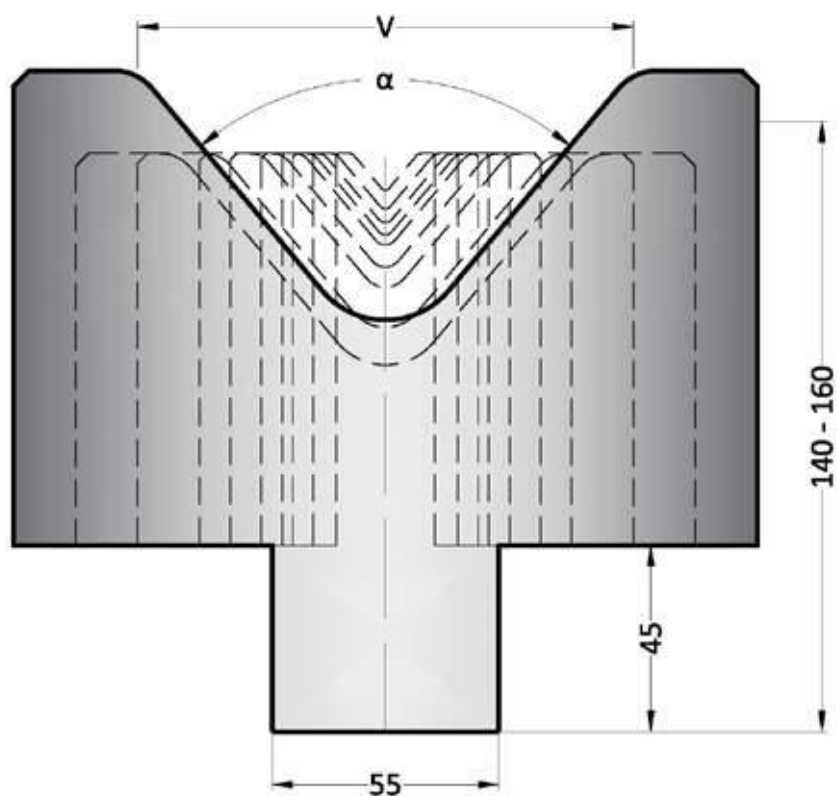

80°	V	H
2.05.215	16	140.00
2.05.216	24	140.00
2.05.217	30	140.00
2.05.218	35	140.00
2.05.219	40	140.00
2.05.220	50	140.00
2.05.221	60	140.00
2.05.222	80	140.00
2.05.223	100	140.00
2.05.224	120	160.00



80°

Red Line

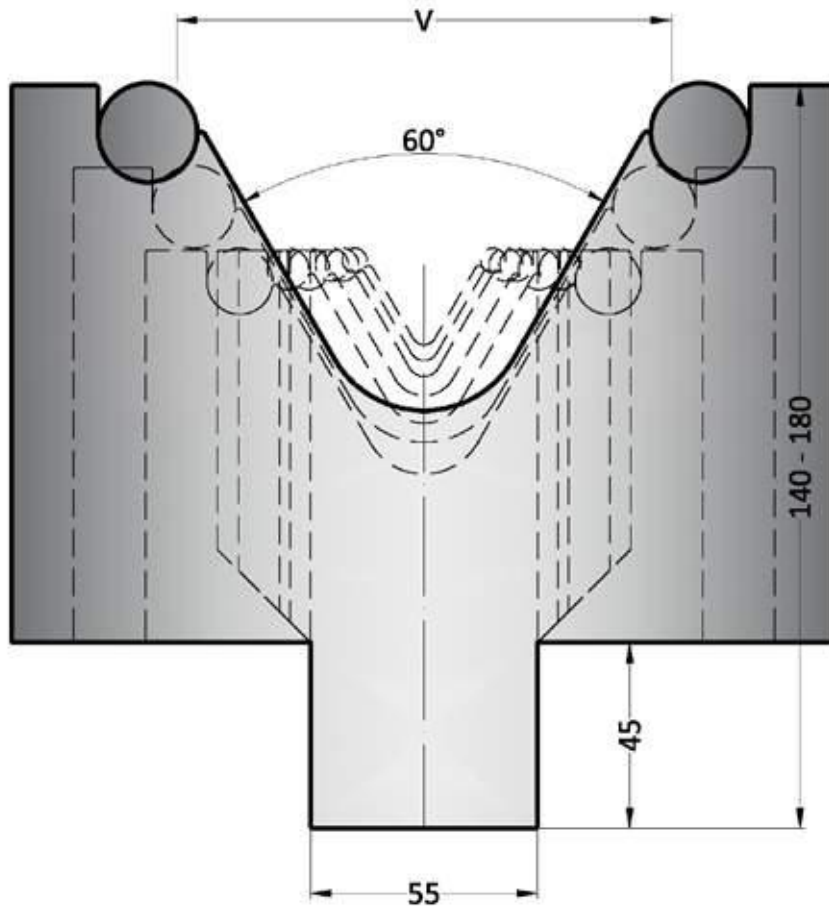

	V	α	H
2.25.011	30	60°	140.00
2.25.012	35	60°	140.00
2.25.013	40	60°	140.00
2.25.014	50	60°	140.00
2.25.015	60	60°	140.00
2.25.016	80	60°	140.00
2.25.017	100	60°	160.00
2.25.018	120	60°	180.00



Westermann-EHT - mit Einlaufwellen 60°

60°

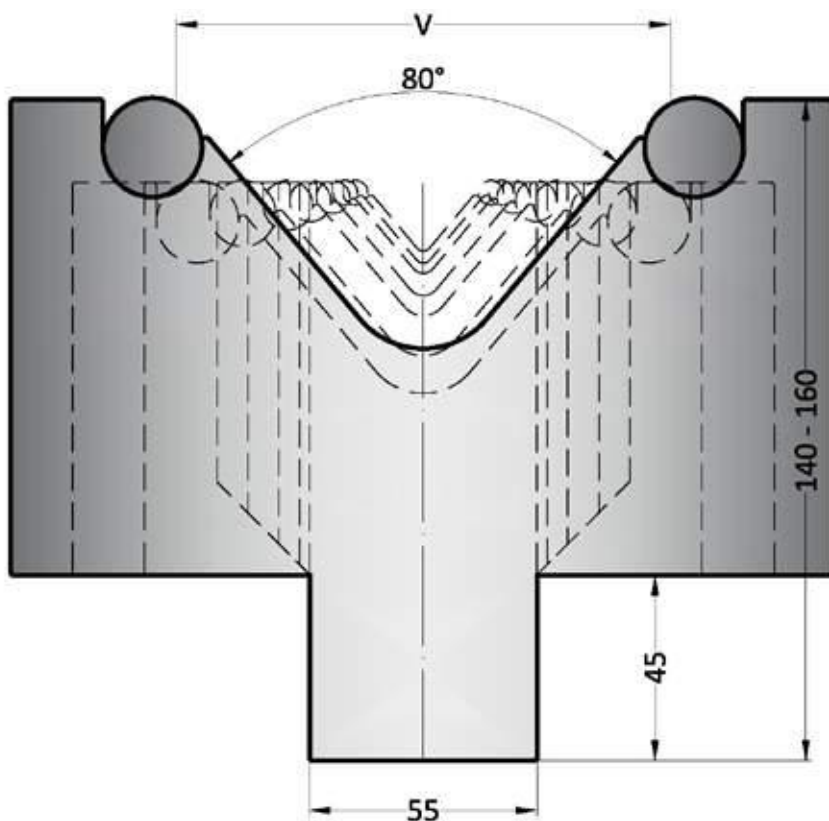

	V	α	H
2.25.019	30	80°	140.00
2.25.020	35	80°	140.00
2.25.021	40	80°	140.00
2.25.022	50	80°	140.00
2.25.023	60	80°	140.00
2.25.024	80	80°	140.00
2.25.025	100	80°	140.00
2.25.026	120	80°	160.00



Westermann 24 liefert
Ihnen Matrizen mit
Welleneinsatz.
(S. 162)

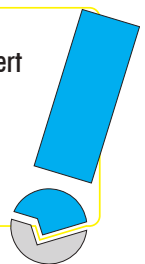

Westermann-EHT - mit Einlaufwellen 80°

80°

Red Line W

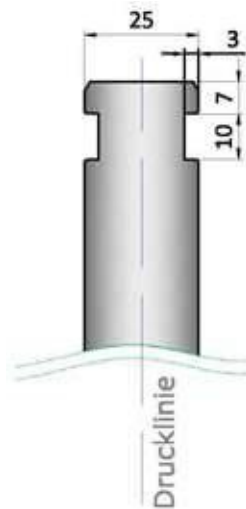

direkt einsetzbar auf Abkantpressen von:
Weinbrenner

Material:

Westermann24 nutzt die vielfältigen Möglichkeiten der Werkstoffkunde, um Ihnen bestmögliche Qualität zu garantieren.

Verwendete Werkstoffe sind:

- I: C45
- II: C45, vergütet auf 800-850N/mm²
- III: 42CrMo4, vergütet auf 950-1050N/mm²
- Werkzeuge auf Anfrage: 1.2312, vergütet auf 1000-1200N/mm²

Ausführung:

Alle Biegeradien sind geschliffen und gehärtet

Werkzeiglängen:

Die Werkzeiglängen sind bei den Artikelnummern angegeben.
Artikelnummern ohne Längenangabe sind auf Anfrage.

sektionierte Werkzeugsätze:

Oberwerkzeuge:
OW 1250mm sektioniert in : 40,45,50,55,60,65,70,75,80,100,100HornL,100HornR,300mm

Belastbarkeit:

Die Belastbarkeit der Werkzeuge ist bei den Artikelnummern angegeben.
Werkzeuge die höher belastet werden sollen, können auf Anfrage konstruiert werden.
(siehe Seite 161)

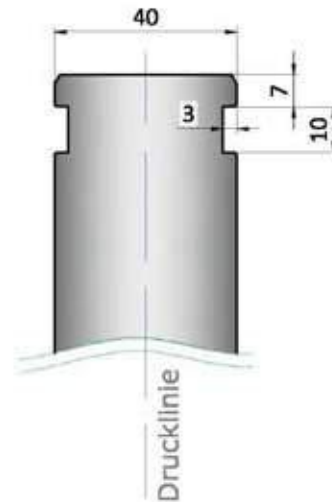

directly able to work on bending presses of:
Weinbrenner

material:

Westermann24 uses the many possibilities of the material engineering, to guarantee best quality.

used materials are:

- I: C45
- II: C45, tempered to 800-850N/mm²
- III: 42CrMo4, tempered to 950-1050N/mm²
- tools on request: 1.2312, tempered to 1000-1200N/mm²

design:

All radii are grinded and hardened

length of the tool:

The tool length are posted with the art-no.
Article- number without length- determination are available on request.

tool sets divided into sections:

Upper tool:
OW 1250mm sectioned in : 40,45,50,55,60,65,70,75,80,100,100HornL,100HornR,300mm

loading capacity:

The loading capacity of the tools is specified by the article number.
Tools which will also be loaded more heavily, can be designed by agreement with the relevant application engineering. (see Page 161)

1.03.175

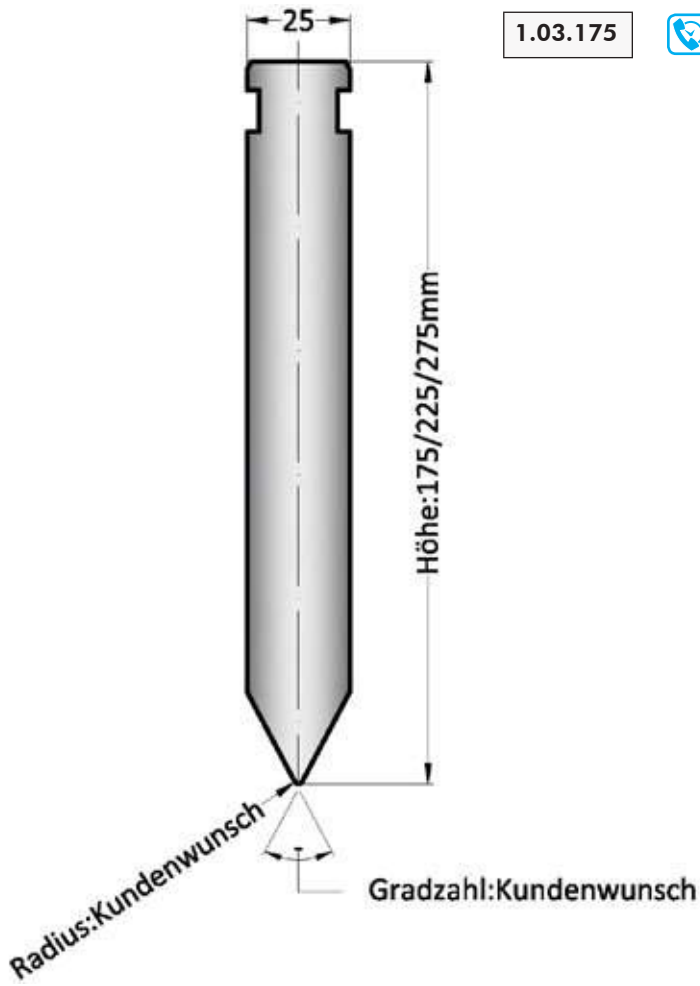

1.03.040

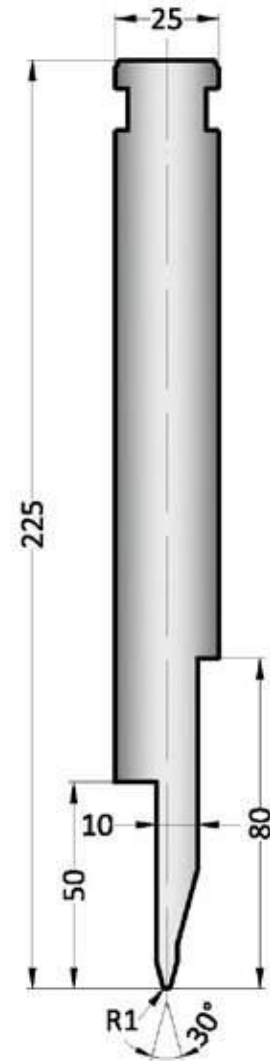

1.03.010

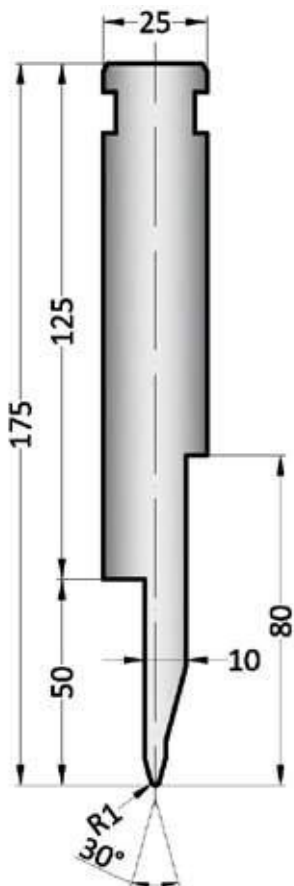

30°

30°

Red Line

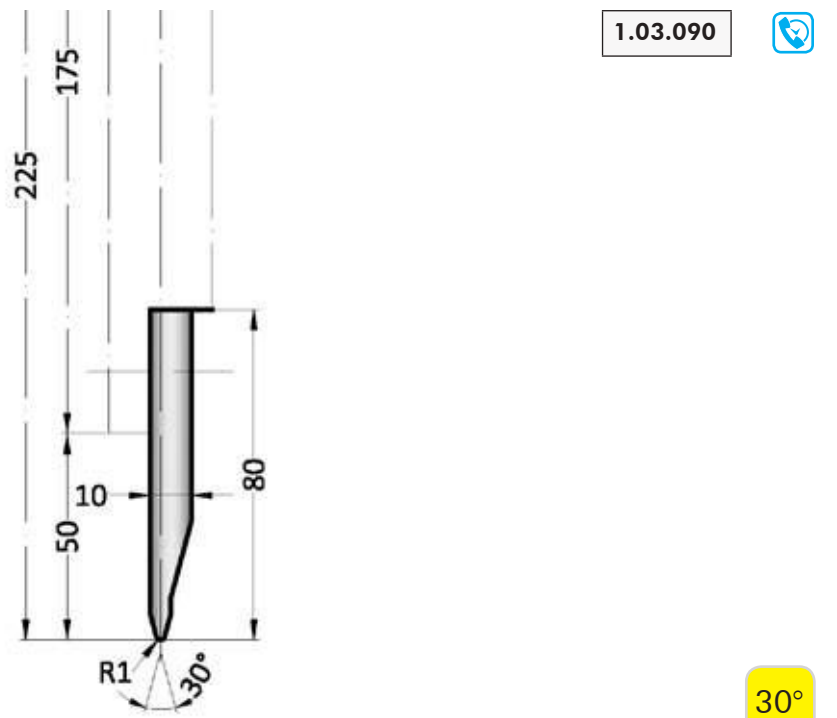
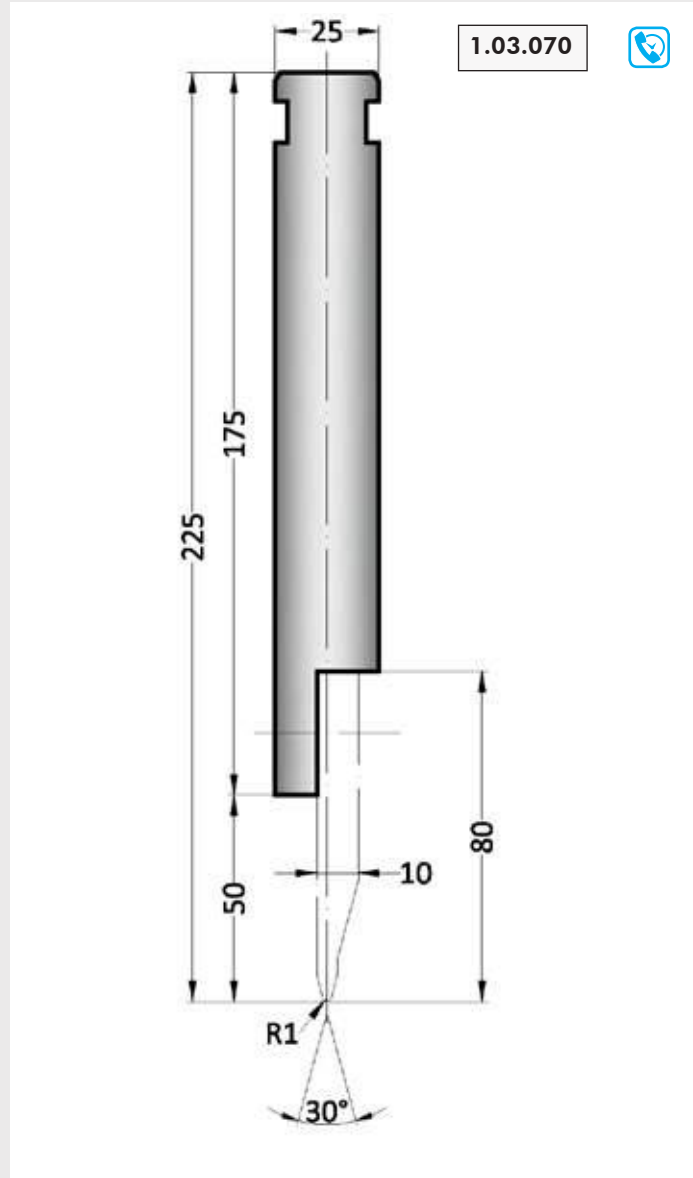
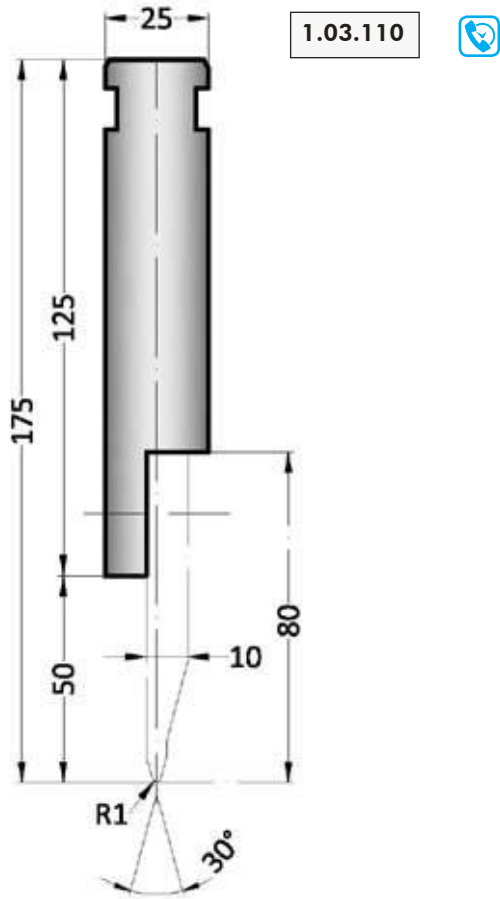

30°

1.03.154

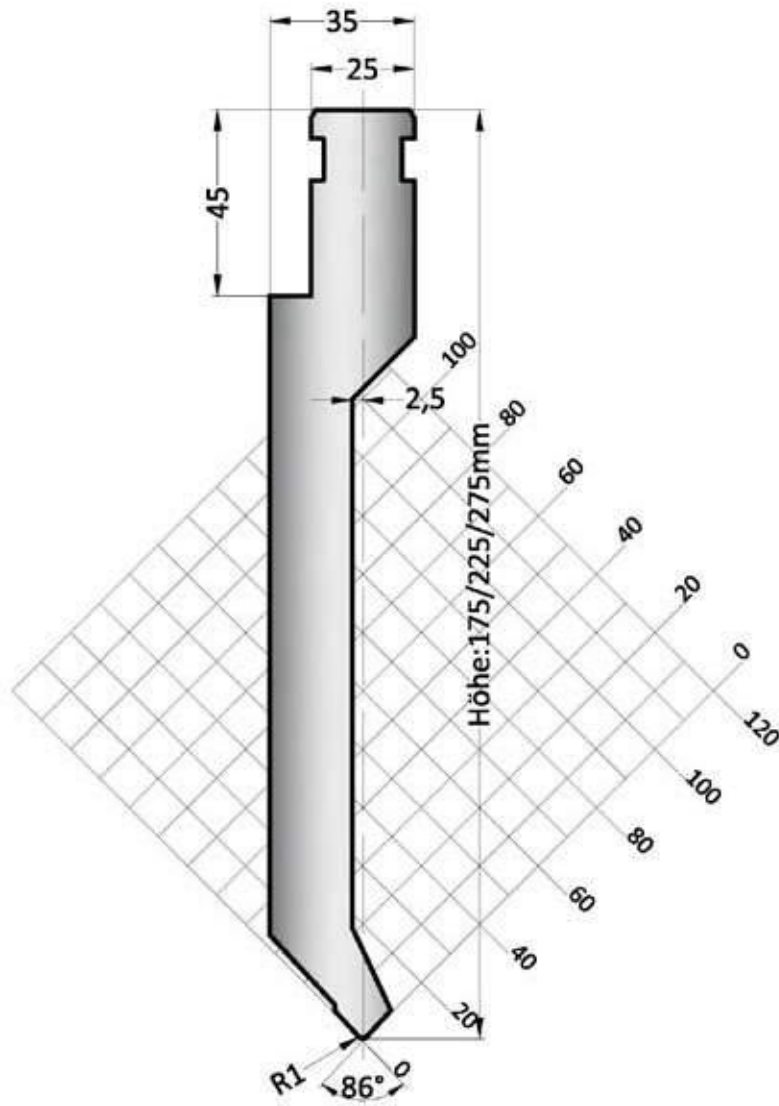

Red Line

86°

1.03.155



Red Line

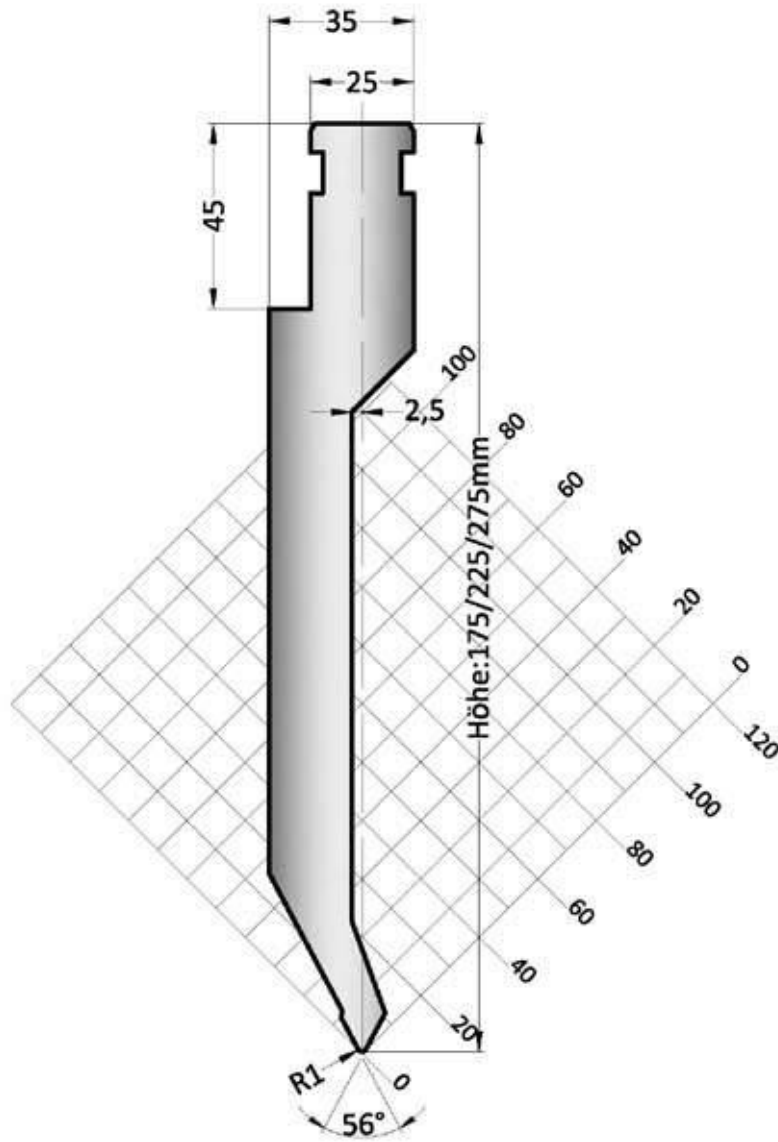

56°

1.03.156

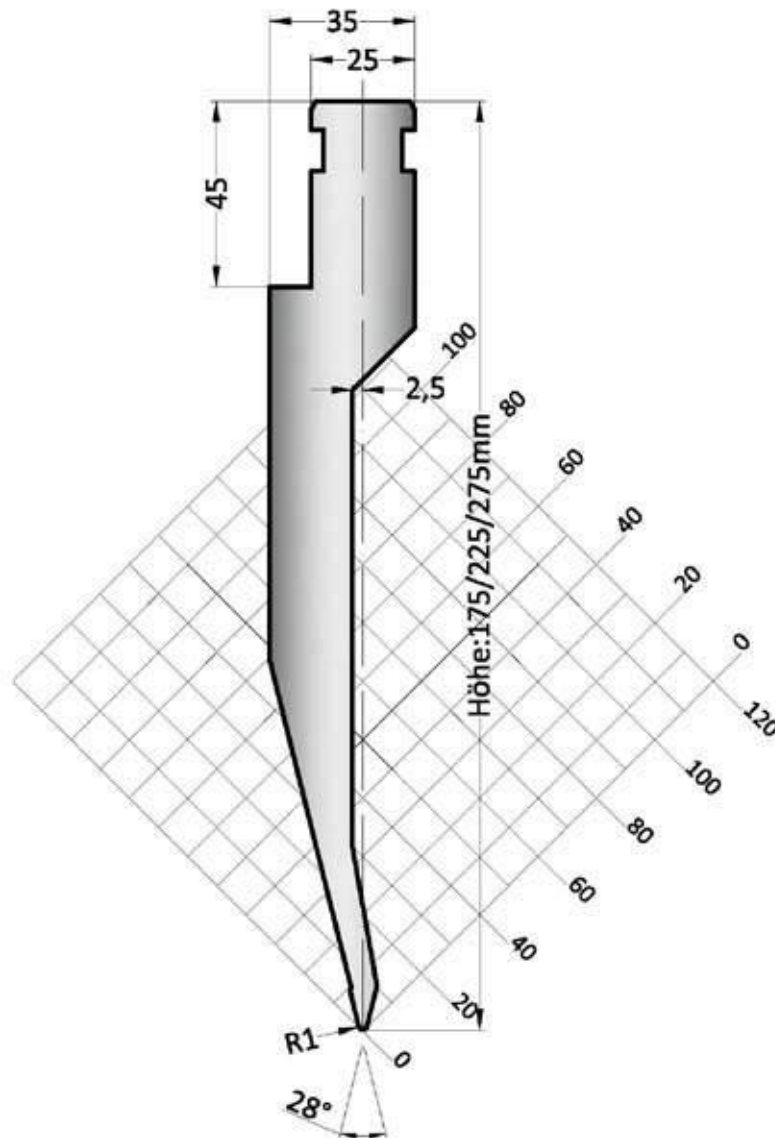

Westermann24 entwickelt für Sie die richtige Werkzeugform für Ihr Produkt. (S. 161)



28°

1.03.162



Red Line

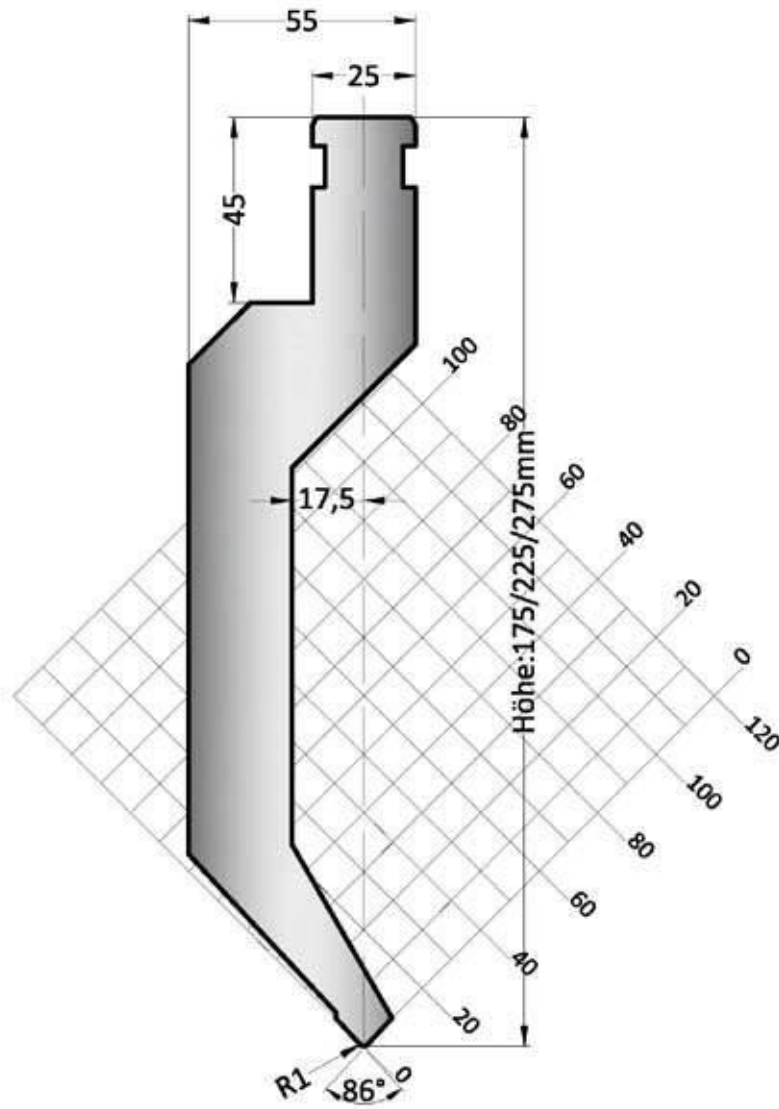

86°

1.03.163

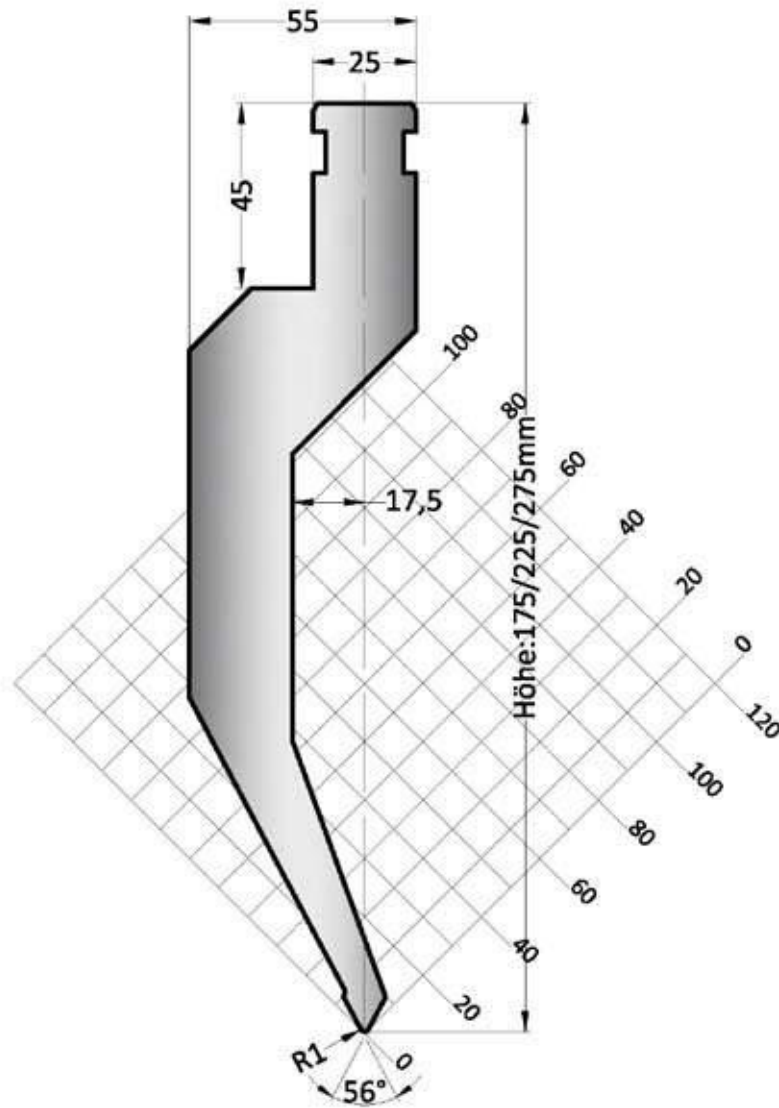

56°

1.03.168



Red Line

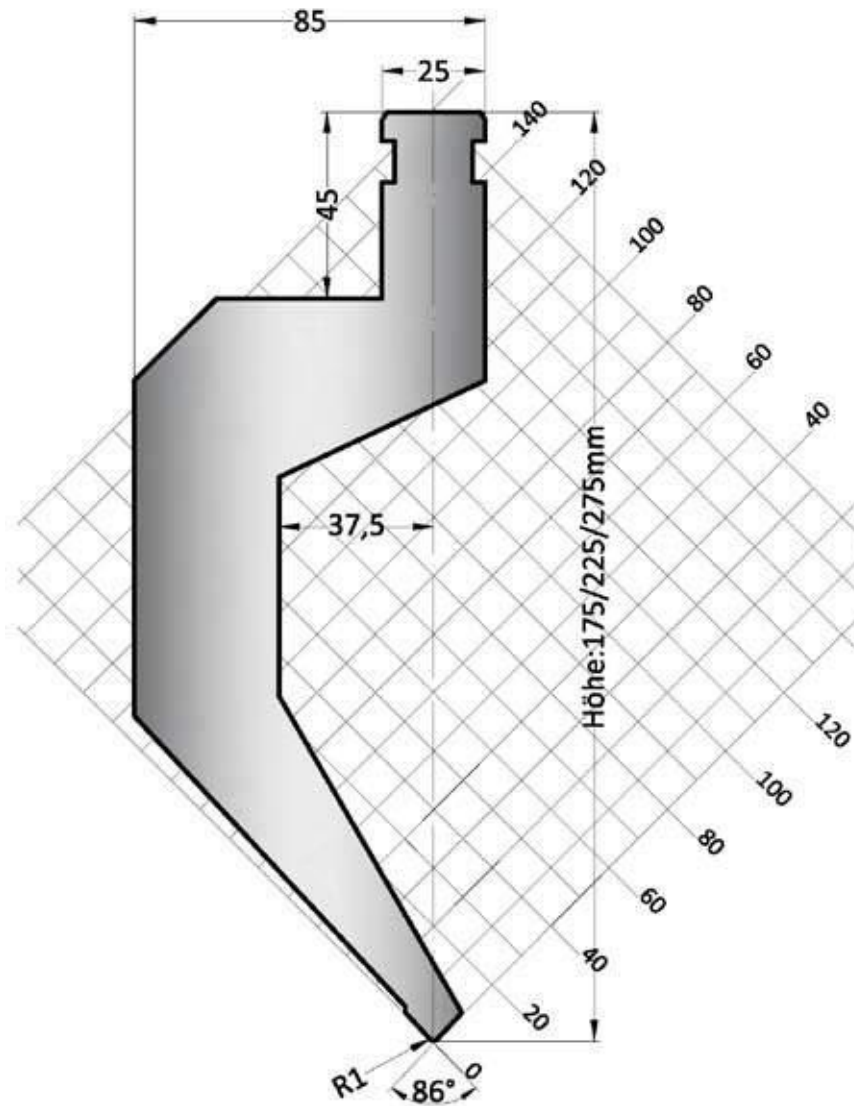

Westermann24 entwickelt für Sie die richtige Werkzeugform für Ihr Produkt. (S. 161)



86°

1.03.169

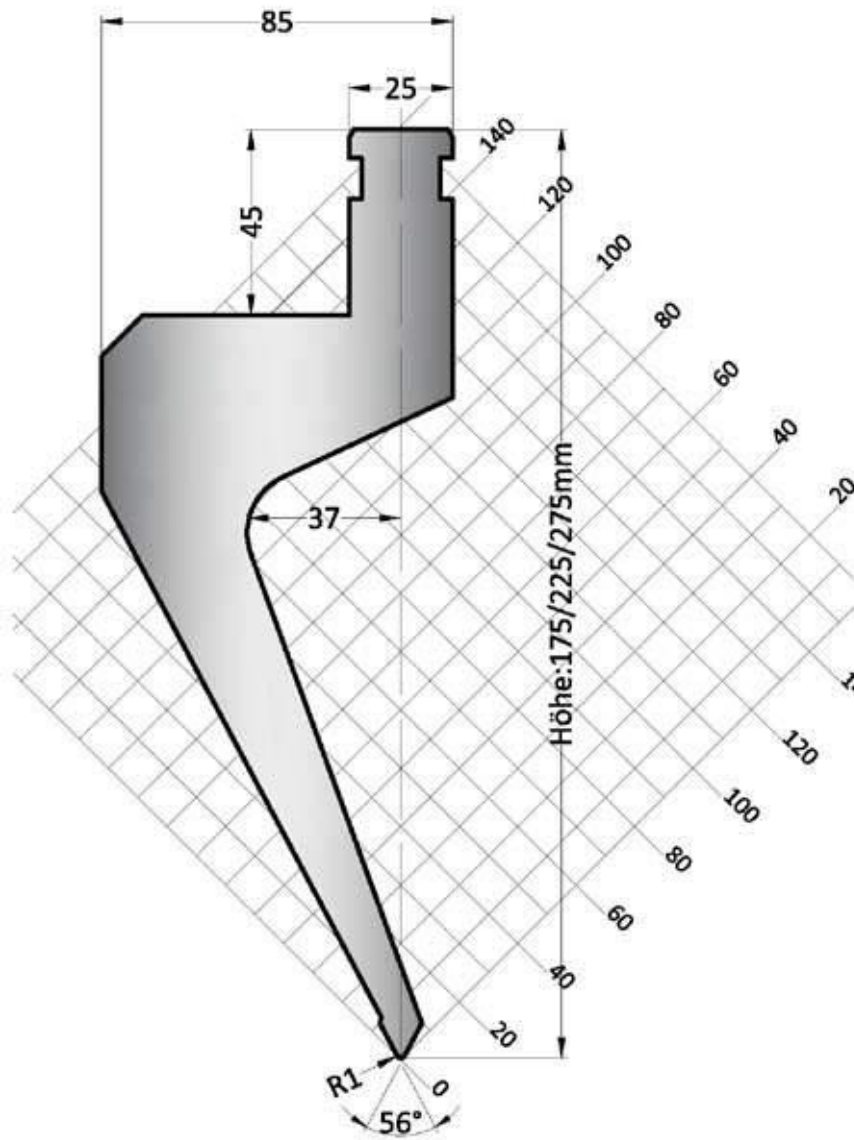

Red Line

56°

Montagebeispiel - Assembly Scheme

	H	Mt
17.570	90.00	I

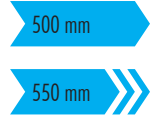

Halter
Holder

Klinge
Blade

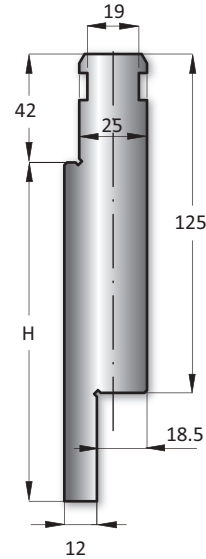
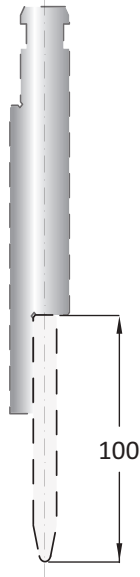

Red Line

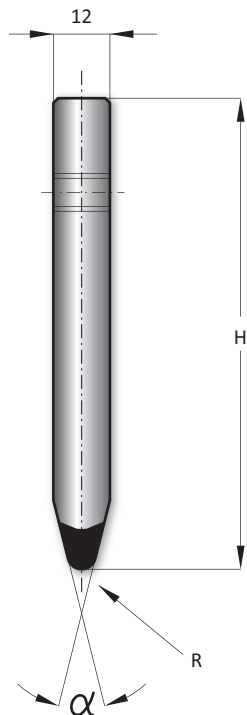
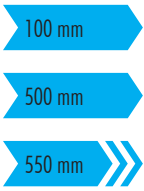

	α	R	H	T/mt	Mt
15.776	86°	1.00	100	100	III
15.774	84°	1.00	100	100	III
15.769	28°	6.00	100	100	III
15.768	28°	5.00	100	100	III
15.767	28°	4.00	100	100	III
15.766	28°	3.00	100	100	III
15.765	28°	2.00	100	100	III
15.763	28°	1.00	100	100	III
15.761	28°	0.50	100	100	III



	T/mt	Mt
17.550	100	I

415 mm

835 mm

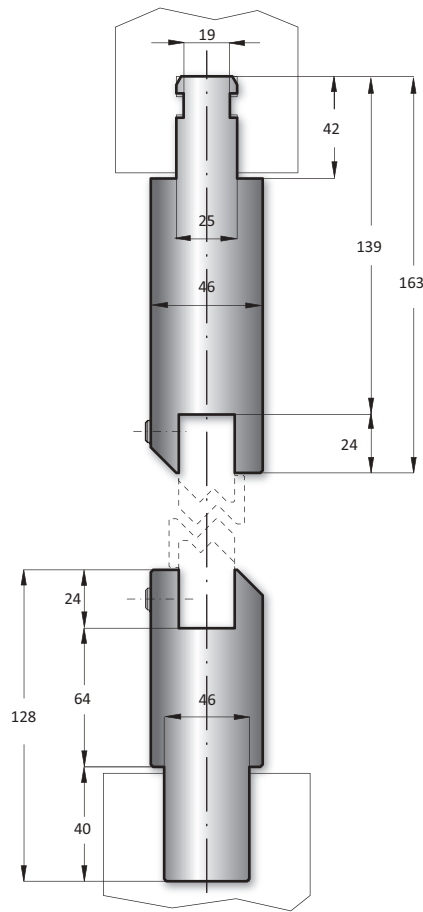

Montagebeispiel - Assembly Scheme

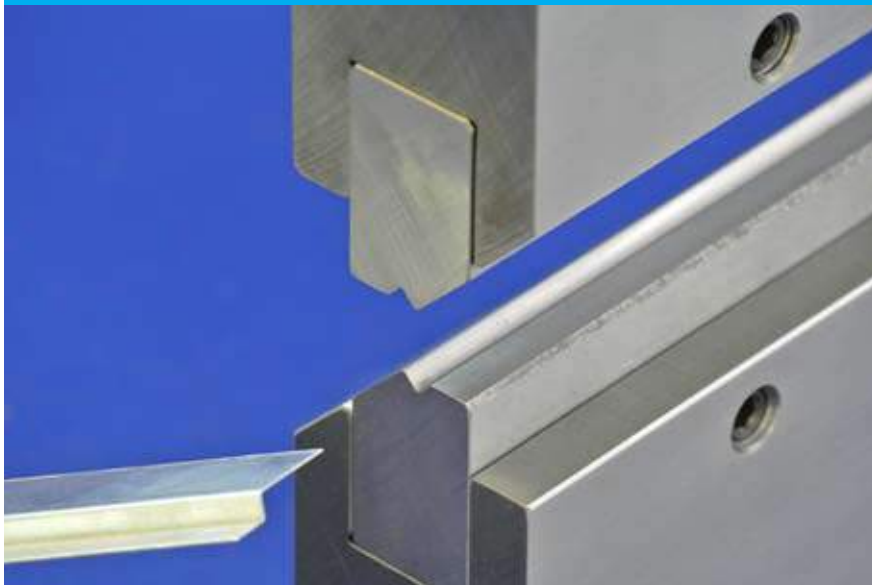

Red Line

Red Line

415 mm
835 mm

	Z	α	T/mt	Mt
40.510	1.00	160°	100	I
40.515	1.50	160°	100	I
40.520	2.00	150°	100	I
40.525	2.50	140°	100	I

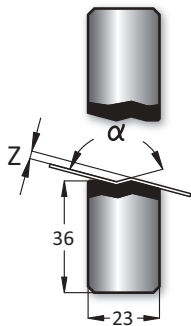

160°
150°
140°

415 mm
835 mm

	Z	α	T/mt	Mt
40.511	1.00	90°	100	I
40.516	1.50	90°	100	I
40.521	2.00	90°	100	I
40.526	2.50	90°	100	I
40.530	3.00	90°	100	I
40.535	3.50	90°	100	I
40.540	4.00	90°	100	I
40.545	4.50	90°	100	I
40.550	5.00	90°	100	I
40.555	5.50	90°	100	I
40.560	6.00	90°	100	I
40.565	6.50	90°	100	I
40.570	7.00	90°	100	I
40.575	7.50	90°	100	I
40.580	8.00	90°	100	I

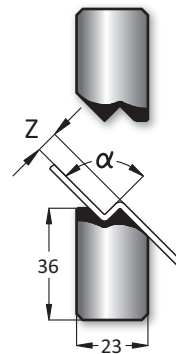

90°

415 mm
835 mm

	Z	α	T/mt	Mt
40.590	9.00	90°	100	I
40.610	10.00	90°	100	I
40.611	11.00	90°	100	I
40.612	12.00	90°	100	I

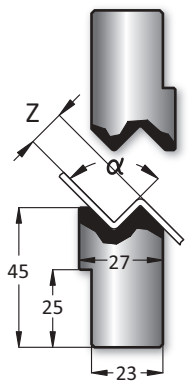

90°

415 mm
835 mm

	Z	α	T/mt	Mt
40.613	13.00	90°	100	I
40.614	14.00	90°	100	I
40.615	15.00	90°	100	I

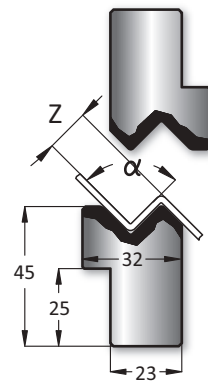

90°

415 mm
835 mm

	Z	α	T/mt	Mt
40.500				I

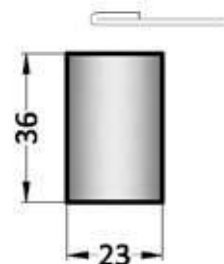

90°

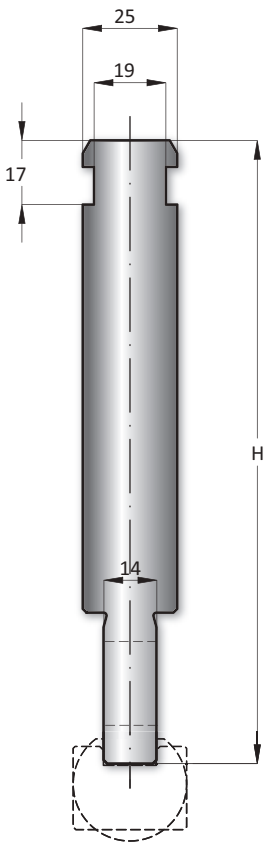

	H	T/mt	Mt
17.510	165.00	80	I

412 mm
830 mm

415 mm
835 mm

	R	A
10.300	7.00	11.50
10.301	7.50	11.50
10.302	8.00	13.00
10.303	9.00	16.00
10.304	10.00	16.00
10.305	11.00	16.00
10.306	11.50	19.00
10.307	12.00	20.00

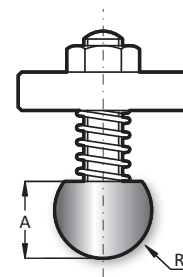

415 mm
835 mm

	R	A	B
10.308	12.50	16.00	21.00
10.309	13.00	17.00	23.00
10.310	14.00	19.00	25.00
10.311	15.00	20.00	27.00
10.312	16.00	21.00	28.00
10.313	17.00	21.50	31.50
10.314	17.50	22.00	32.00
10.315	19.00	25.00	32.00
10.316	20.00	24.00	34.00
10.317	22.50	25.00	33.00
10.318	25.00	29.00	39.00
10.319	27.50	34.00	44.00
10.320	30.00	34.00	44.00
10.321	35.00	45.00	55.00
10.322	40.00	45.00	55.00
10.323	45.00	50.00	60.00
10.324	50.00	54.00	64.00

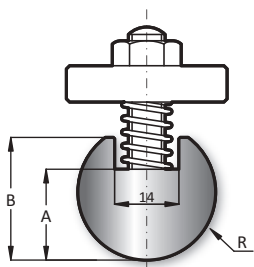

415 mm
835 mm

	A	B
10.325	17.00	22.00

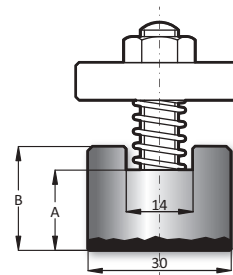

Westermann24 liefert
Ihnen Lösungen für
Halter mit Einsatz.
(S. 163)

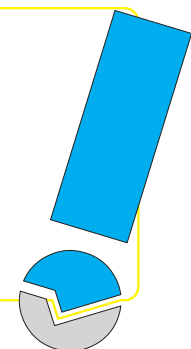

Red Line W

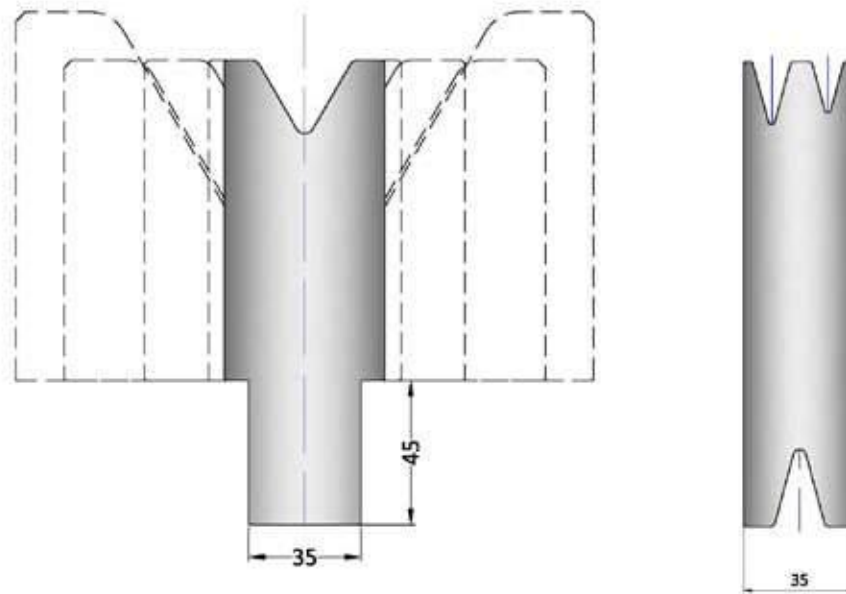

direkt einsetzbar auf Abkantpressen von:
Weinbrenner

directly able to work on bending presses of:
Weinbrenner

Material:

Westermann24 nutzt die vielfältigen Möglichkeiten der Werkstoffkunde, um Ihnen bestmögliche Qualität zu garantieren.

Verwendete Werkstoffe sind:

- I: C45
- II: C45, vergütet auf 800-850N/mm²
- III: 42CrMo4, vergütet auf 950-1050N/mm²
- Werkzeuge auf Anfrage: 1.2312, vergütet auf 1000-1200N/mm²
- Alternativ: 16MnCr5 Einsatzgehärtet

Ausführung:

Alle Biegeradien sind geschliffen und gehärtet

Werkzeuglängen:

Die Werkzeuglängen sind bei den Artikelnummern angegeben.
Artikelnummern ohne Längenangabe sind auf Anfrage.

sektionierte Werkzeugsätze:

Unterwerkzeuge:
UW 1250mm sektioniert in : 40,45,50,55,60,65,70,75,80,100,200,300mm

Belastbarkeit:

Die Belastbarkeit der Werkzeuge ist bei den Artikelnummern angegeben.
Werkzeuge die höher belastet werden sollen, können auf Anfrage konstruiert werden.
(siehe Seite 161)

material:

Westermann24 uses the many possibilities of the material engineering, to guarantee best quality.

used materials are:

- I: C45
- II: C45, tempered to 800-850N/mm²
- III: 42CrMo4, tempered to 950-1050N/mm²
- tools on request: 1.2312, tempered to 1000-1200N/mm²
- Alternatively: 16MnCr5, case hardened

design:

All radii are grinded and hardened

length of the tool:

The tool length are posted with the art-no.
Article- number without length- determination are available on request.

tool sets divided into sections:

Lower tool:
UW 1250mm sectioned in : 40,45,50,55,60,65,70,75,80,100,200,300mm

loading capacity:

The loading capacity of the tools is specified by the article number.
Tools which will also be loaded more heavily, can be designed by agreement with the relevant application engineering. (see Page 161)

	V	α	H
2.15.070	z.B. 8, 12, 20	30°	120.00
2.15.120	z.B. 8, 12, 20	60°	120.00
2.15.121	z.B. 8, 12, 20	86°	120.00

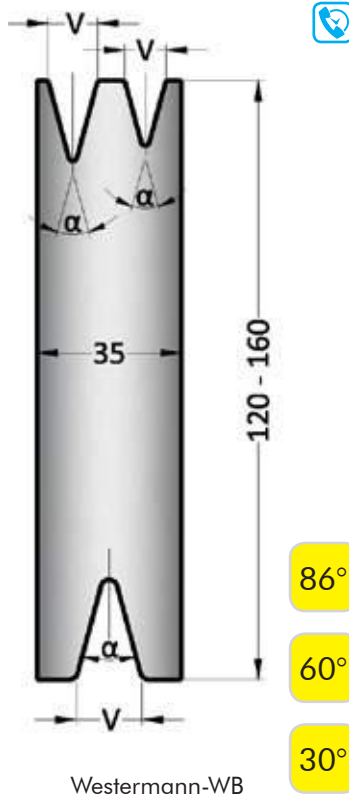

	V	α	H
2.16.125	z.B. 8, 12, 20	30°	145.00
2.16.126	z.B. 8, 12, 20	60°	145.00
2.16.127	z.B. 8, 12, 20	86°	145.00

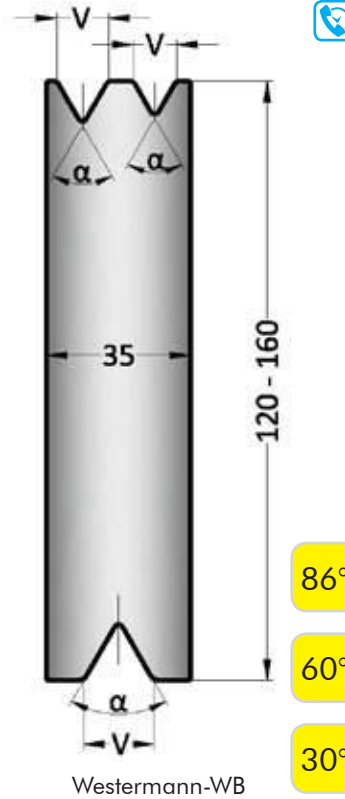

	V	α	H
2.17.035	z.B. 8, 12, 20	30°	160.00
2.17.036	z.B. 8, 12, 20	60°	160.00
2.17.034	z.B. 8, 12, 20	86°	160.00

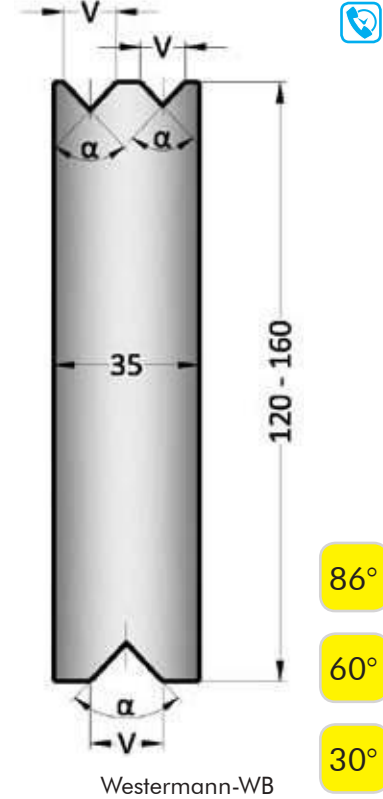

Red Line

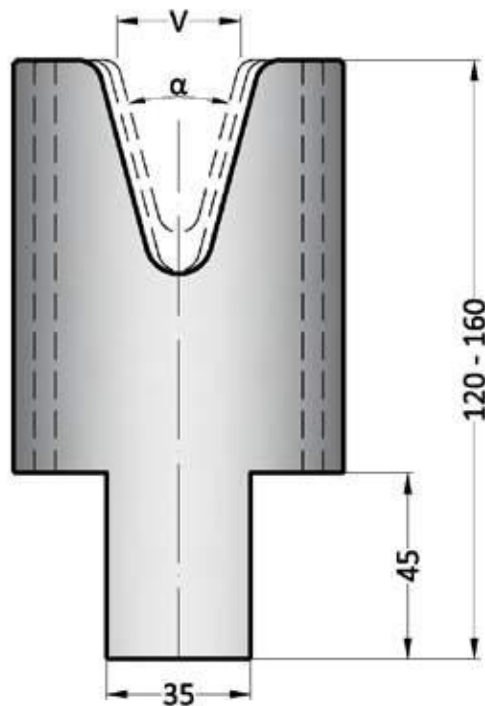

Westermann-WB

30°	V	H
2.15.100	30	120.00
2.15.101	35	120.00
2.15.102	40	120.00

30°	V	H
2.16.100	30	145.00
2.16.101	35	145.00
2.16.102	40	145.00

30°	V	H
2.17.010	30	160.00
2.17.011	35	160.00
2.17.012	40	160.00

30°

Red Line

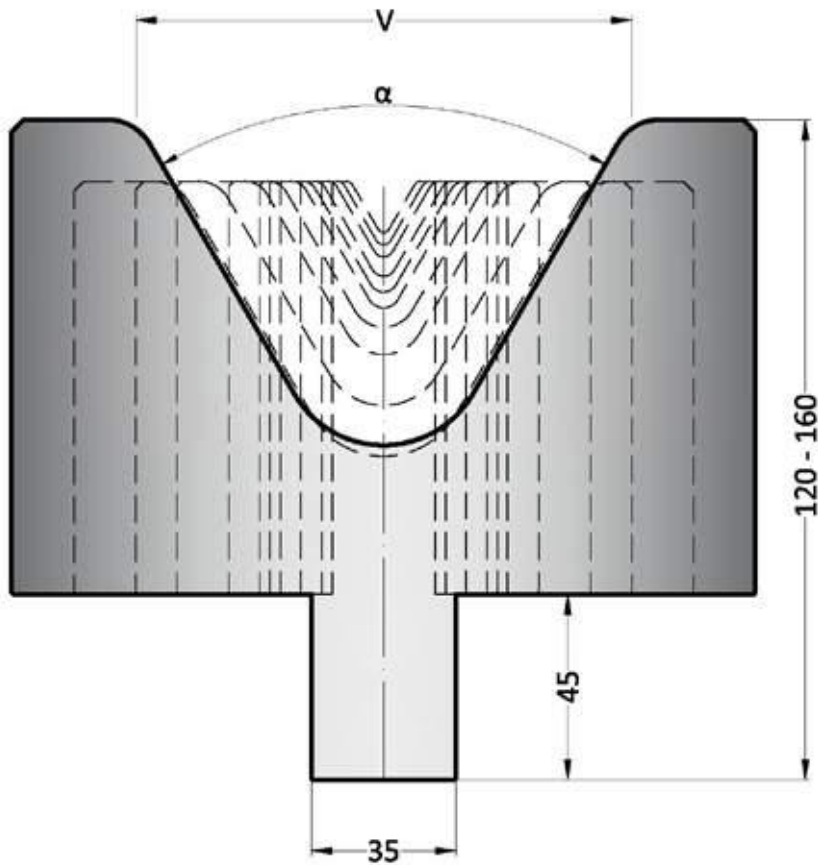

Westermann-WB

60°	V	H
2.15.105	24	120.00
2.15.106	30	120.00
2.15.107	35	120.00
2.15.108	4	120.00
2.15.109	50	120.00
2.15.110	60	120.00



60°	V	H
2.16.105	24	145.00
2.16.106	30	145.00
2.16.107	35	145.00
2.16.108	40	145.00
2.16.109	50	145.00
2.16.110	60	145.00
2.16.111	80	145.00
2.16.112	100	145.00



60°	V	H
2.17.015	24	160.00
2.17.016	30	160.00
2.17.017	35	160.00
2.17.018	40	160.00
2.17.019	50	160.00
2.17.020	60	160.00
2.17.021	80	160.00
2.17.022	100	160.00
2.17.023	120	160.00



60°

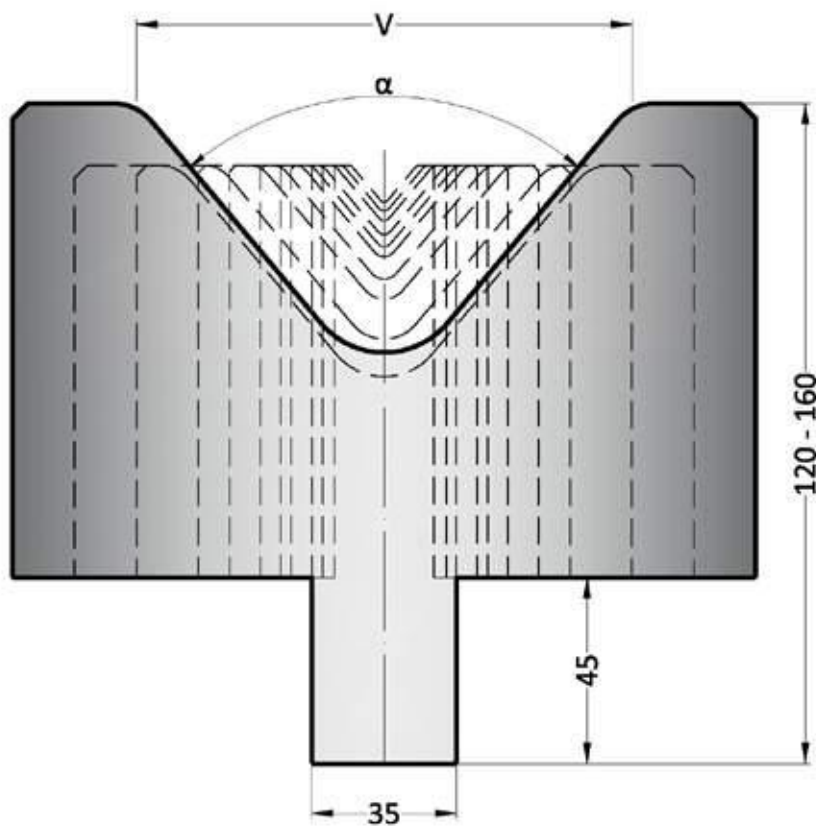

Westermann-WB

80°	V	H
2.15.114	30	120.00
2.15.115	35	120.00
2.15.116	40	120.00
2.15.117	50	120.00
2.15.118	60	120.00
2.15.119	80	120.00



80°	V	H
2.16.116	24	145.00
2.16.117	30	145.00
2.16.118	35	145.00
2.16.119	40	145.00
2.16.120	50	145.00
2.16.121	60	145.00
2.16.122	80	145.00
2.16.123	100	145.00



80°	V	H
2.17.026	24	160.00
2.17.027	30	160.00
2.17.028	35	160.00
2.17.029	40	160.00
2.17.030	50	160.00
2.17.031	60	160.00
2.17.032	80	160.00
2.17.033	100	160.00
2.17.034	120	160.00



Red Line

80°

	V	α	H
2.26.011	30	60°	145.00
2.26.012	35	60°	145.00
2.26.013	40	60°	145.00
2.26.014	50	60°	145.00
2.26.015	60	60°	145.00
2.26.016	80	60°	145.00
2.26.017	100	60°	160.00
2.26.018	120	60°	175.00

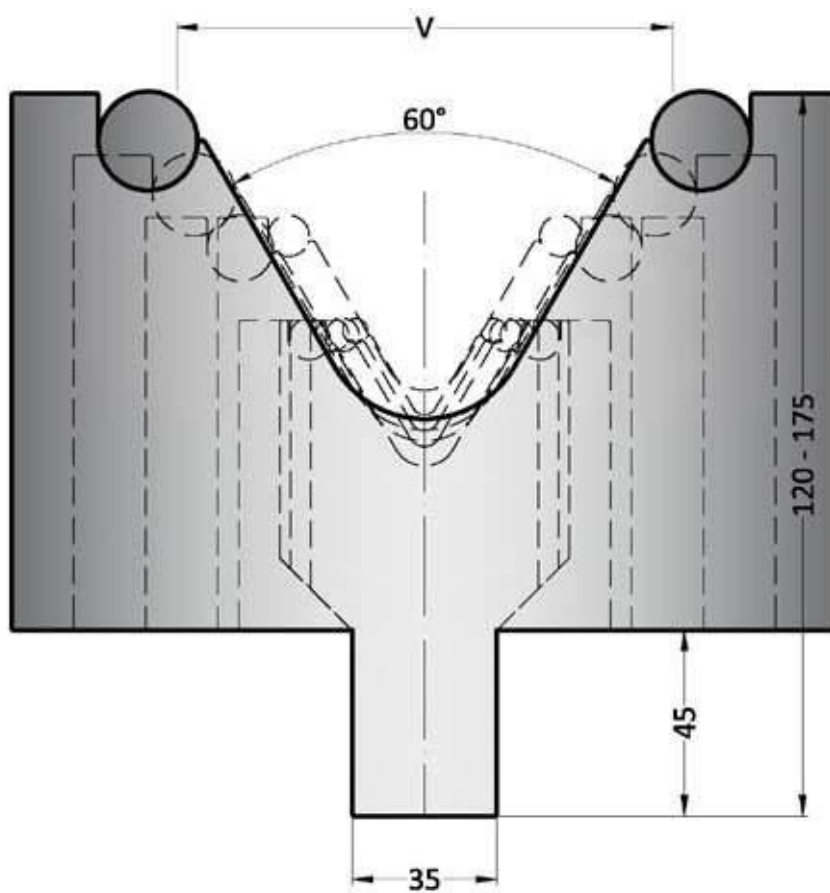

Westermann-WB - mit Einlaufwellen 60°

60°

Westermann 24 liefert
Ihnen Matrizen mit
Welleneinsatz.
(S. 162)

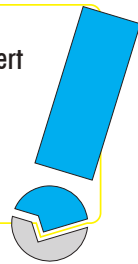

	V	α	H
2.26.019	30	80°	120.00
2.26.020	35	80°	120.00
2.26.021	40	80°	120.00
2.26.022	50	80°	120.00
2.26.023	60	80°	120.00
2.26.024	80	80°	145.00
2.26.025	100	80°	145.00
2.26.026	120	80°	160.00

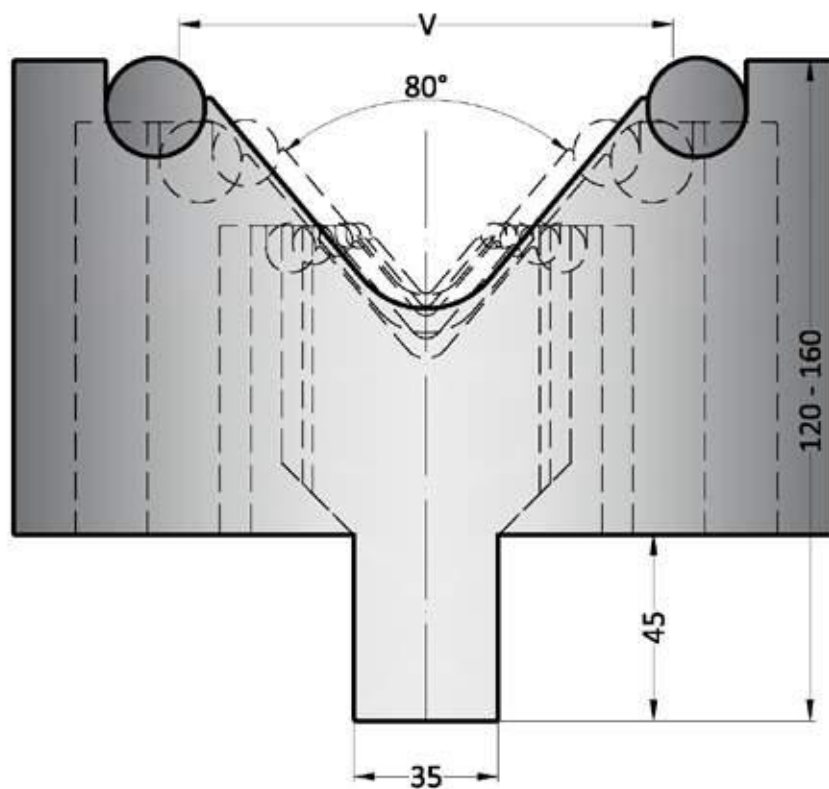

Westermann-WB - mit Einlaufwellen 80°

80°

Red Line H

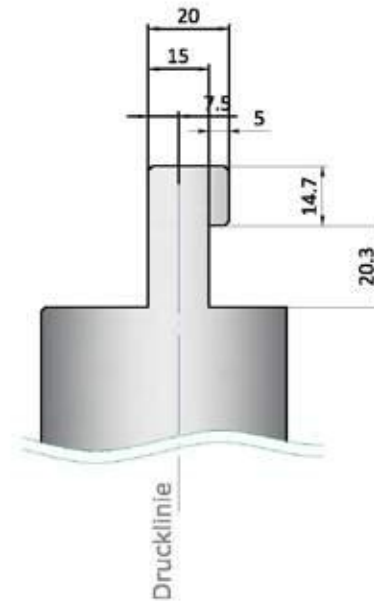
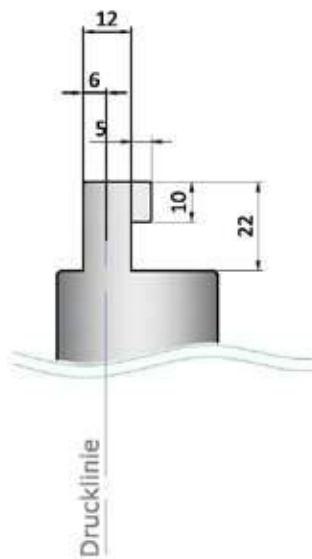

direkt einsetzbar auf Abkantpressen von:
Haco

directly able to work on bending presses of:
Haco

Material:

Westermann24 nutzt die vielfältigen Möglichkeiten der Werkstoffkunde, um Ihnen bestmögliche Qualität zu garantieren.

Verwendete Werkstoffe sind:

- I: C45
- II: C45, vergütet auf 800-850N/mm²
- III: 42CrMo4, vergütet auf 950-1050N/mm²
- Werkzeuge auf Anfrage: 1.2312, vergütet auf 1000-1200N/mm²

Ausführung:

Alle Biegeradien sind geschliffen und gehärtet

Werkzeuglängen:

Die Werkzeuglängen sind bei den Artikelnummern angegeben.
Artikelnummern ohne Längenangabe sind auf Anfrage.

sektionierte Werkzeugsätze:

Oberwerkzeuge:
OW 1050mm sektioniert in : 20,25,30,35,40,200,500,100HornL,100HornR

Belastbarkeit:

Die Belastbarkeit der Werkzeuge ist bei den Artikelnummern angegeben.
Werkzeuge die höher belastet werden sollen, können auf Anfrage konstruiert werden.
(siehe Seite 161)

material:

Westermann24 uses the many possibilities of the material engineering, to guarantee best quality.

used materials are:

- I: C45
- II: C45, tempered to 800-850N/mm²
- III: 42CrMo4, tempered to 950-1050N/mm²
- tools on request: 1.2312, tempered to 1000-1200N/mm²

design:

All radii are grinded and hardened

length of the tool:

The tool length are posted with the art-no.
Article- number without length- determination are available on request.

tool sets divided into sections:

Upper tool:
OW 1050mm sectioned in : 20,25,30,35,40,200,500,100HornL,100HornR

loading capacity:

The loading capacity of the tools is specified by the article number.
Tools which will also be loaded more heavily, can be designed by agreement with the relevant application engineering. (see Page 161)

1.07.010

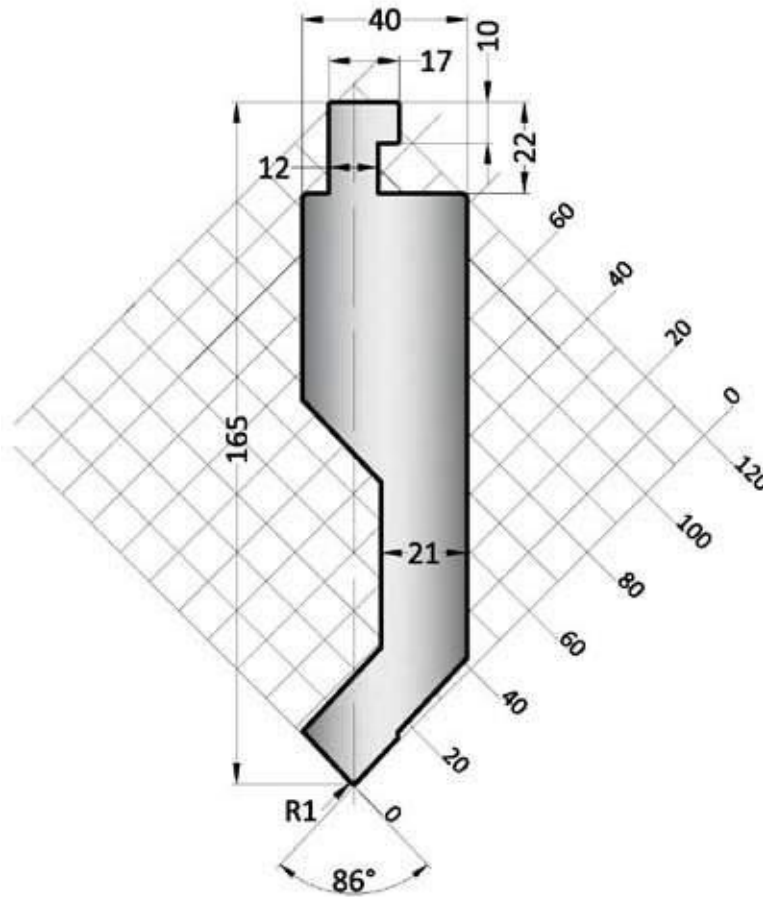

1.07.040

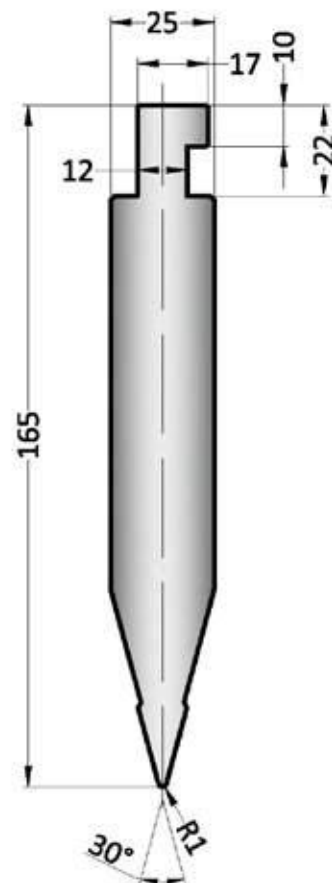

Red Line

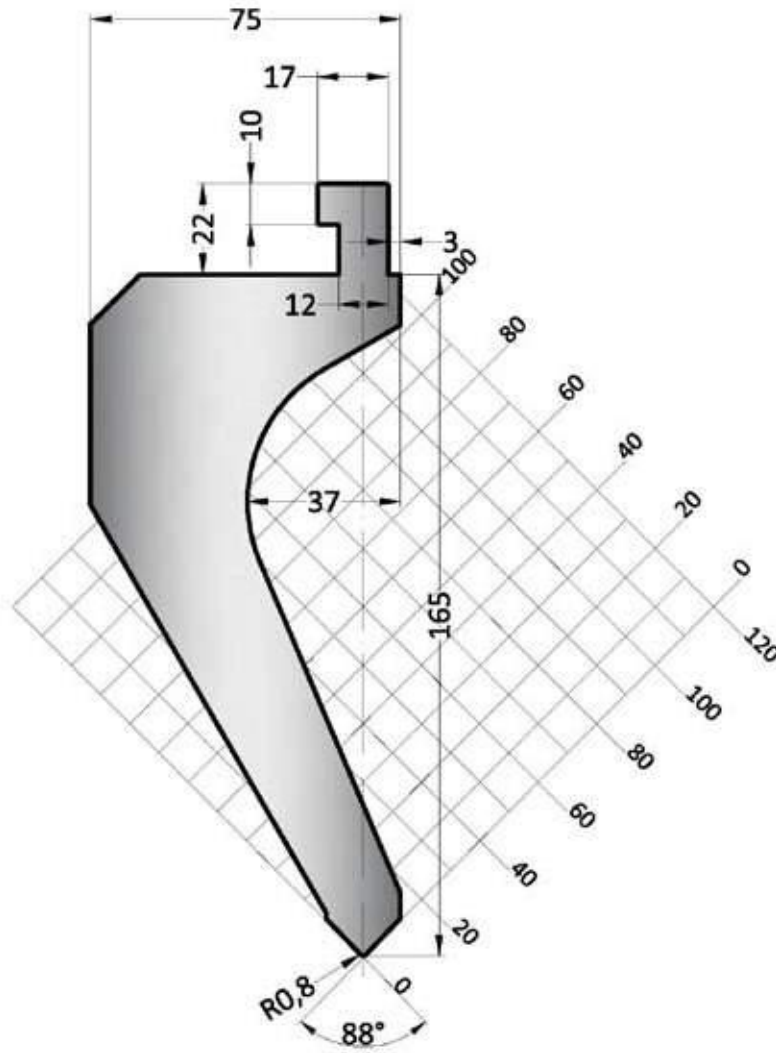

1.07.061



88°

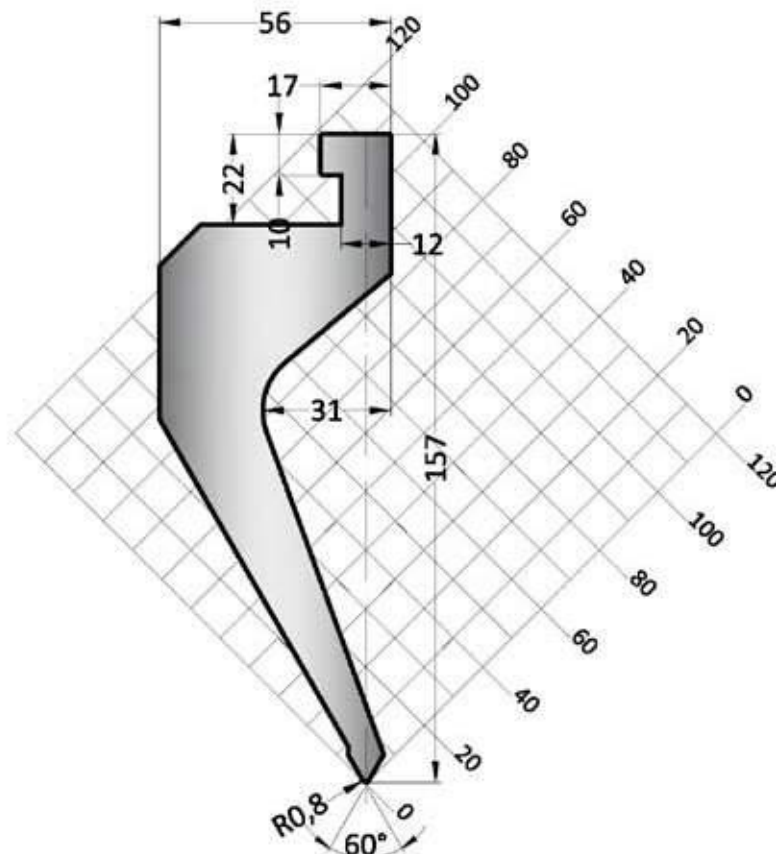

1.07.062



60°

1.07.070

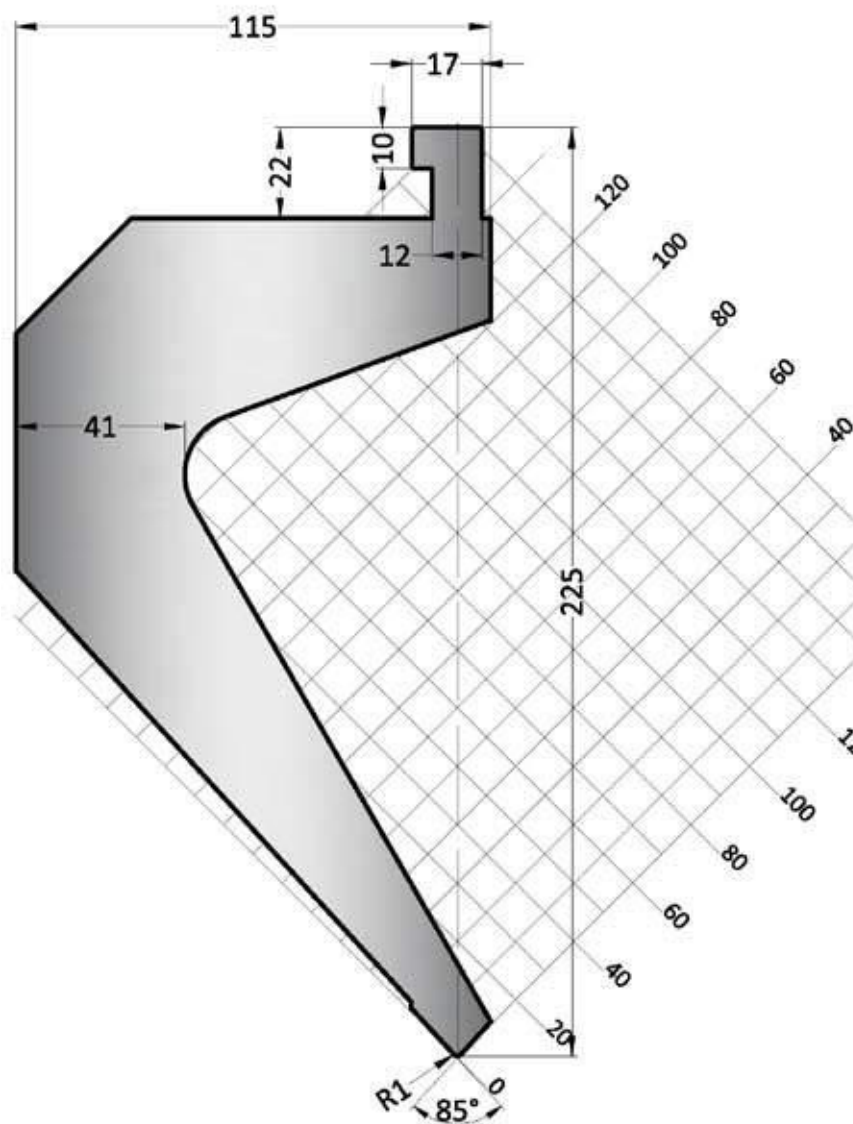

Red Line

85°

1.07.071



Red Line

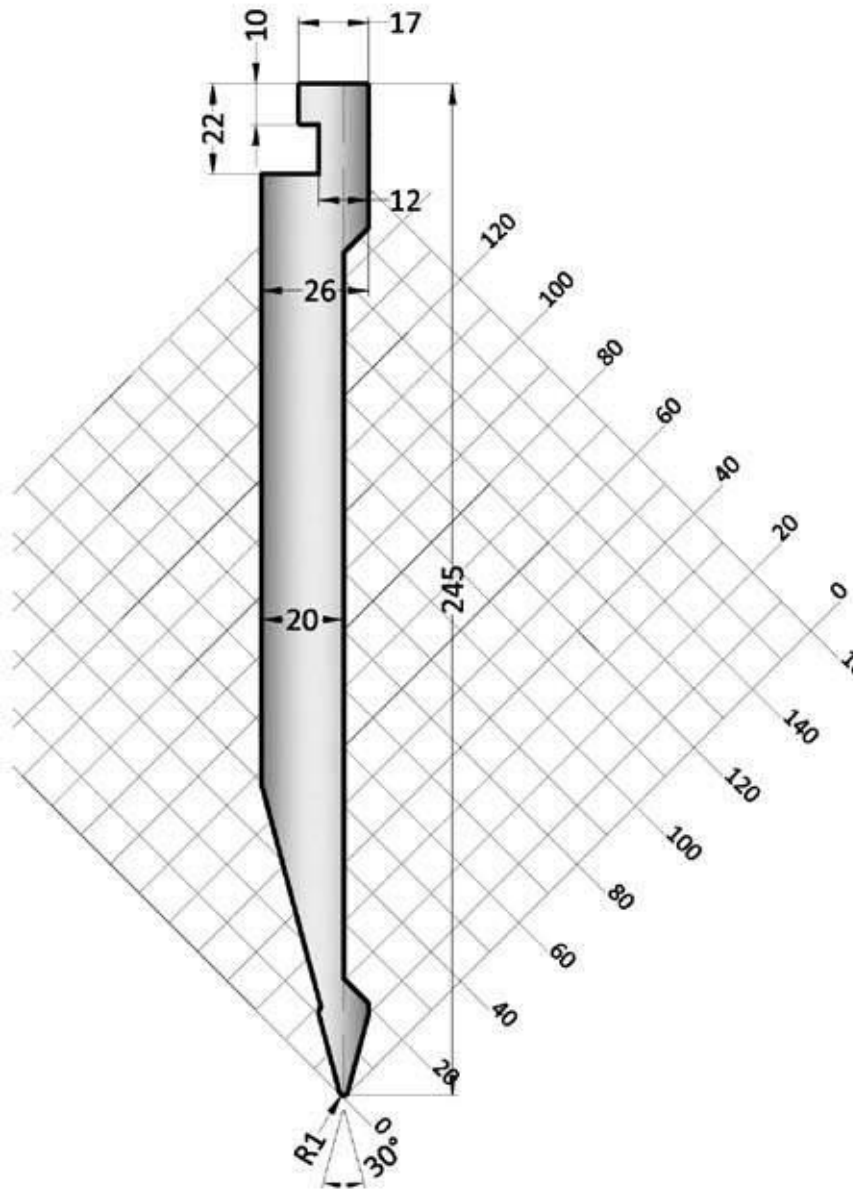

30°

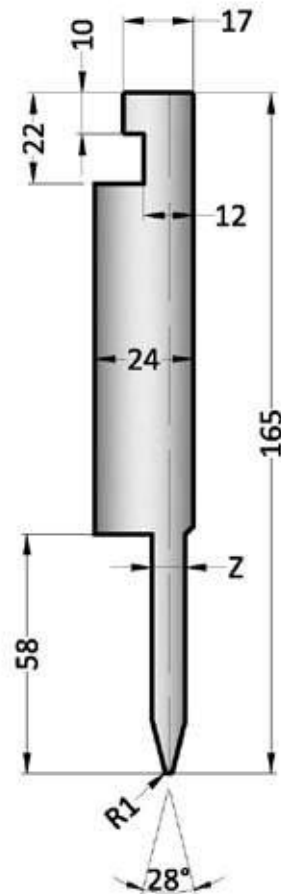

	α	R	H	Z
1.07.063	28°	1.00	165.00	8
1.07.064	28°	1.00	165.00	10
1.07.065	28°	1.00	165.00	12



28°

Red Line

	R	H	Z	T/mt	Mt
20.550	1.00	80.00	8,2	50	II
20.554	1.00	80.00	10,2	50	II
20.560	1.00	80.00	12,2	50	II

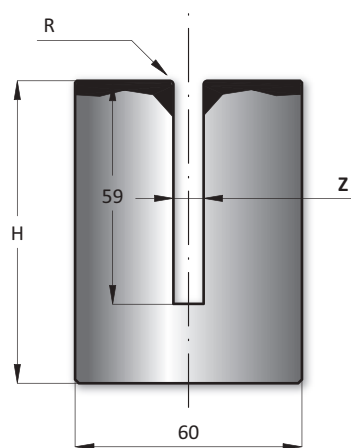

- 415 mm
- 835 mm
- 835 mm



Red Line

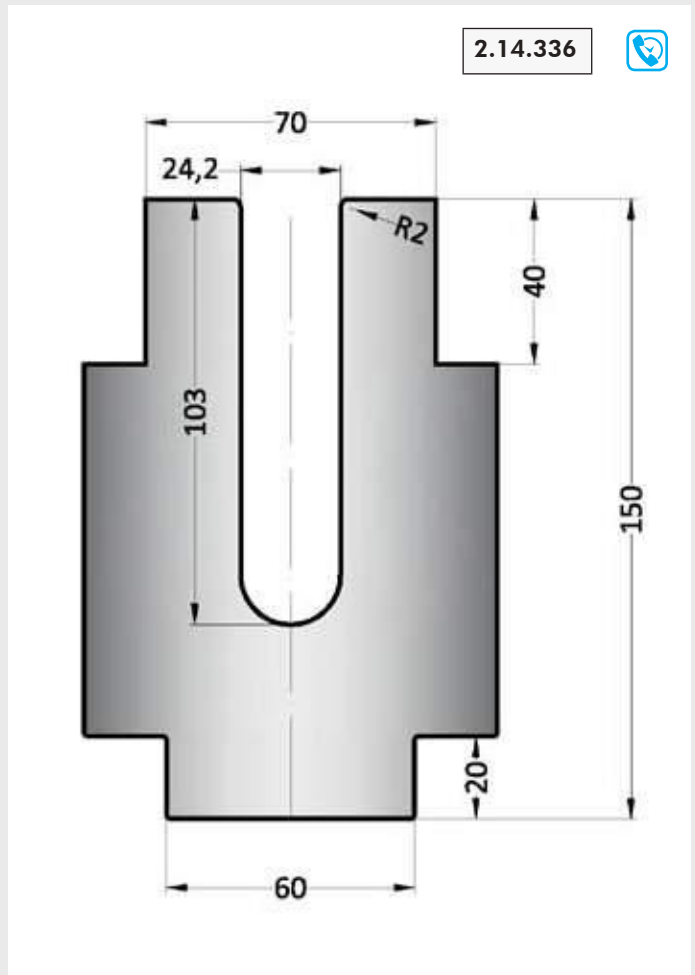
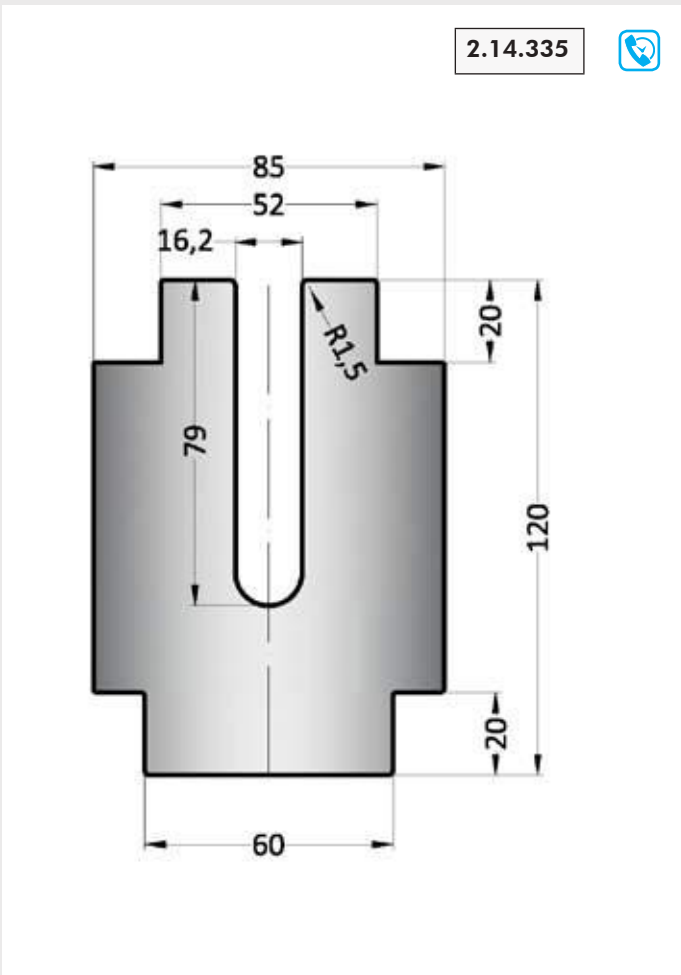
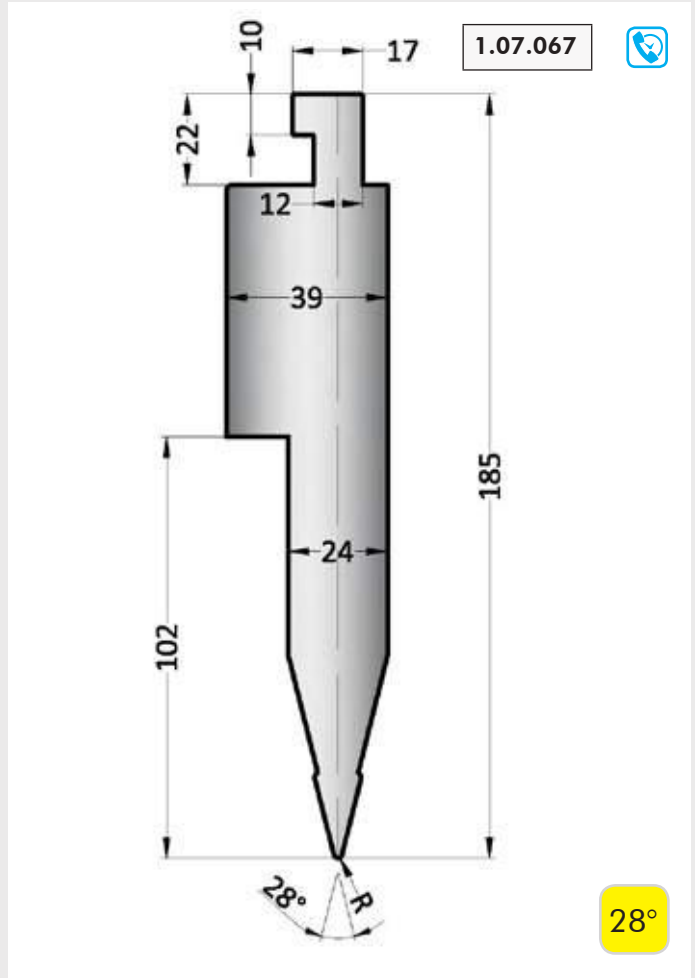
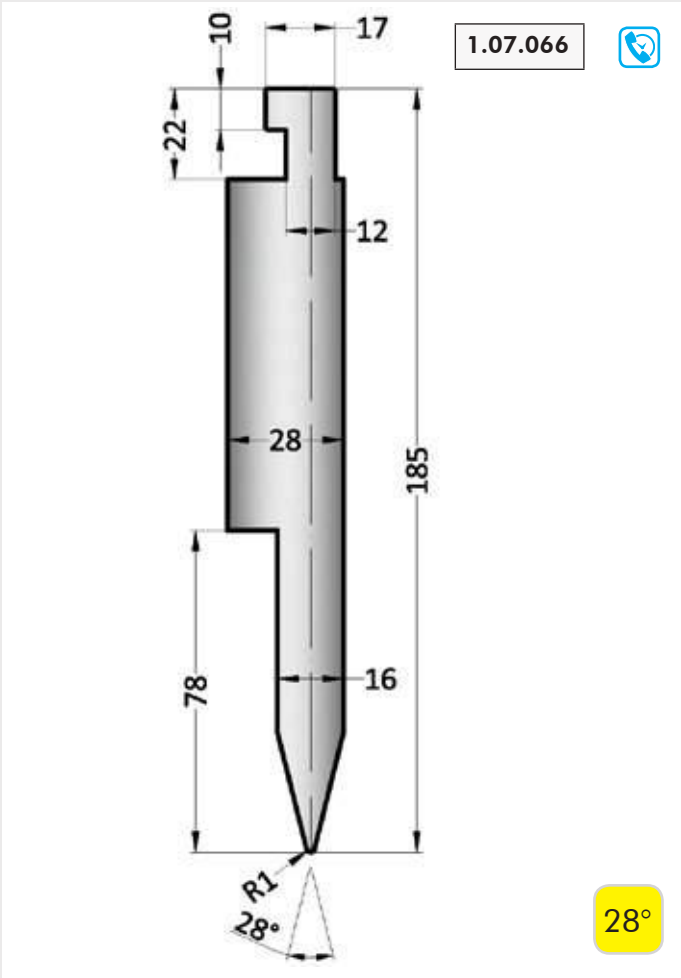

Sonderwerkzeuge / Special tools

Blue Line

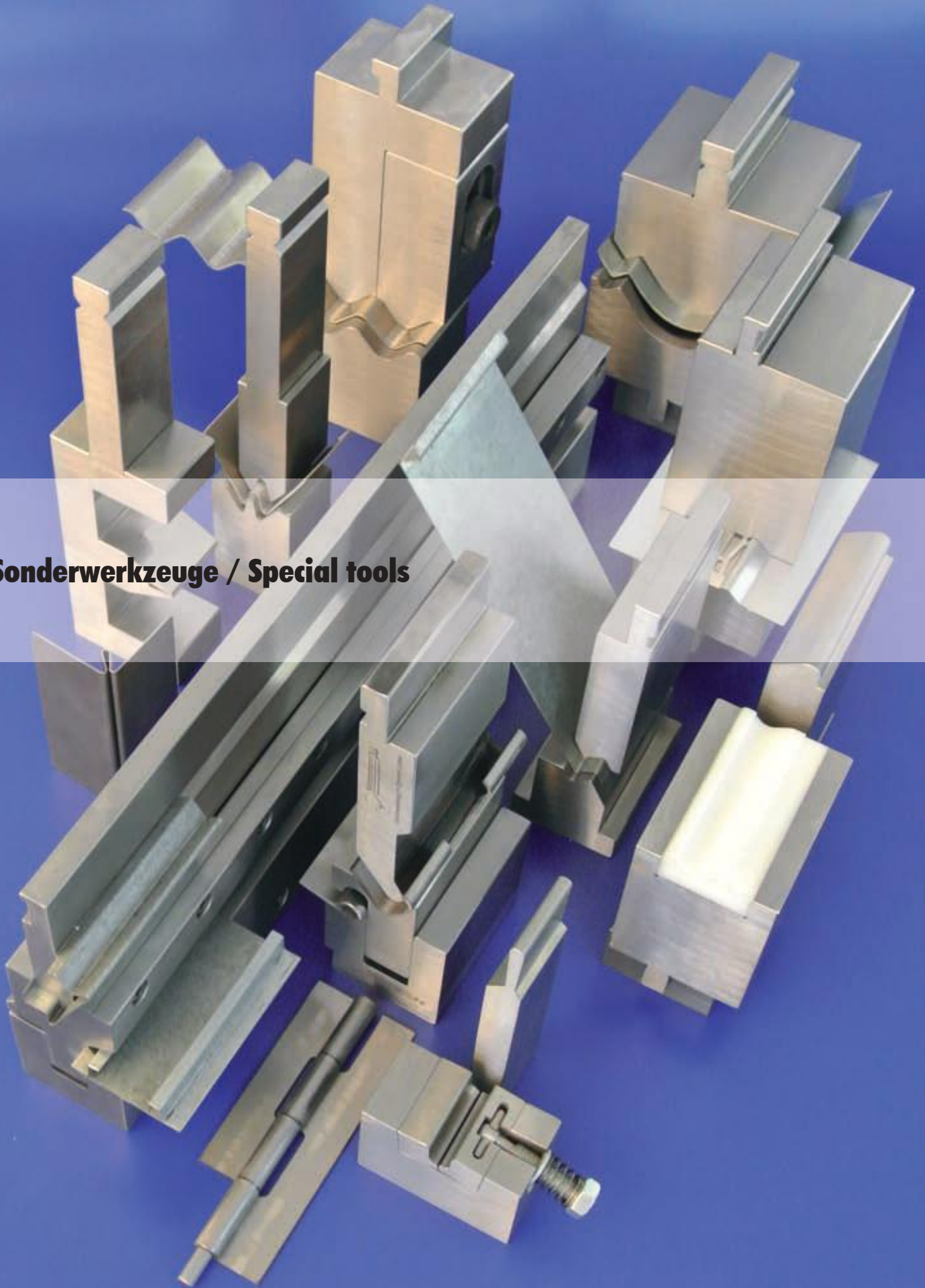

Aufnahme nicht gefunden?

holder not found?

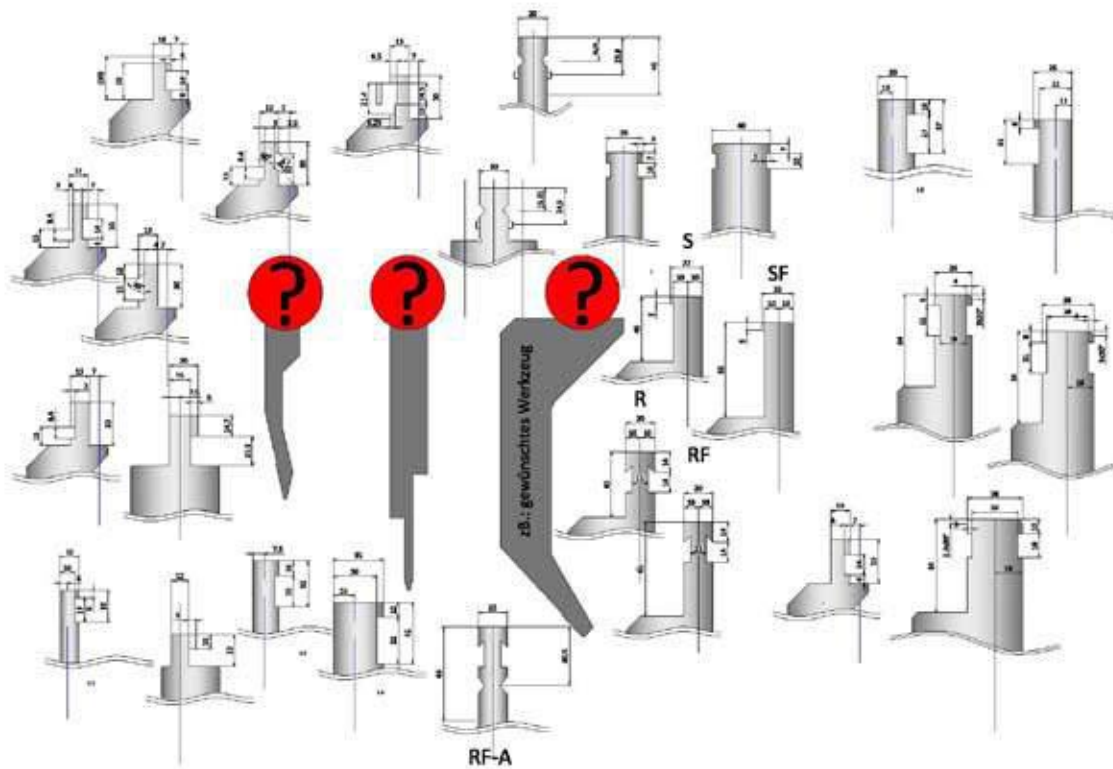

 Sie haben Ihr Werkzeug gefunden, aber nicht mit der richtigen Aufnahme?

 Sie haben nicht das richtige Werkzeug gefunden?

Lösung:
Westermann24 liefert Ihnen das gewünschte Werkzeug für Ihre Maschine.

 You have found your tool, but the right holder is missed?

 You haven't found the right tool?

Solution:
Westermann24 delivers the desired tool for your machine.

Entwicklung

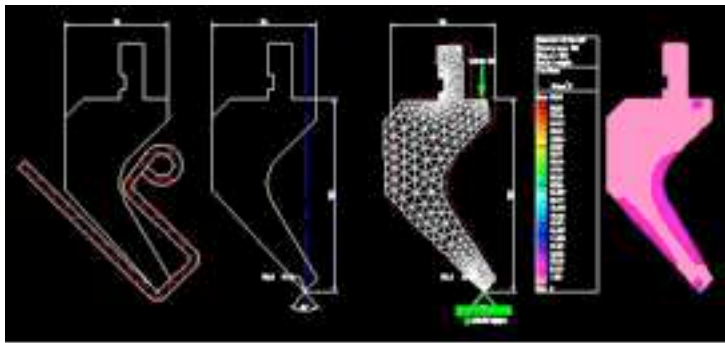

Westermann24 erstellt für jedes Werkzeug eine Presskraftberechnung. / Westermann24 prepares for every tool a calculation of the pressing force.

Westermann24 liefert Ihnen die richtige Werkzeugform für Ihr Produkt. Entscheidend dafür ist die Belastbarkeit.

Westermann24 bietet höchste Qualität durch die Auswahl unterschiedlicher Werkstoffeigenschaften in Kombination mit verschiedenen Härteverfahren.

Vorteil:

- Standzeitverlängerung durch hochwertigere Werkstoffe und Härteverfahren

Development

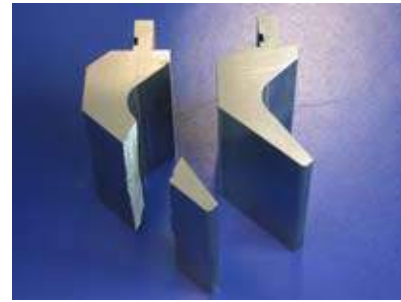

Vergleich zu anderen Werkstoffen / compared to other materials

Westermann24 delivers the right form of the tool for your product. Decisive is the mechanical loadability.

Westermann24 provides highest quality by the selection different properties of the material in combination with different hardening processes.

Advantage:

- Extended lifetime because of high-quality material and processes of hardening

Test Sonderwerkzeuge



Westermann 24 liefert dem Kunden ein bereits erprobtes Werkzeug. Die Werkzeugform ist bereits korrigiert. Vor Auslieferung hat der Kunde bereits erste Musterbleche zur Begutachtung erhalten.

Test Special tools

Westermann 24 delivers a well proved tool to the customer. The shape of the tool is ready adjusted. Before the delivery stands the assessment from the sample panels from the customer.

Matrizen mit Einlaufwellen

Dies with shafts of inlet



Problem:

Herkömmliche Matrizen unterliegen oft trotz Härtung einem hohen Verschleiß. Besonders dickere Blechstärken hinterlassen ihre Spuren. Ungenaue Kantungen und Kantabdrücke sind vorprogrammiert.

Lösung :

Westermann 24 liefert Ihnen Matrizen mit Welleneinsatz. Das eigentliche Werkzeug wird mittels gehärtet geschliffener Welleneinsätze zum Werkzeugträger. Die Werkzeugsegmentierung kann wahlweise durch den Einsatz eines einteiligen Welleneinsatzes auch stoßfrei eingesetzt werden. Der Kunde kann die Einlaufwellen einfach und kostengünstig vor Ort wechseln. Die Welleneinsätze können zusätzlich mit einer Wellenbefestigung geliefert werden. Es können auch Einsätze in verschiedenen Materialien eingesetzt werden. (z.B. Ampco gegen ferritische Abriebe)

Vorteile:

- geringer Verschleiß durch Einlaufwellen
- gehärtet geschliffene Einlaufwellen CF53/60HRC
- niedrige Werkzeugkosten bei Ersatz
- Einlaufwellen einfach und schnell, selbst auswechselbar
- Reduzierung der Presskraft
- Reduzierung von Kantabdrücken

Problem:

normal dies have usual a high abrasion despite of tempering. Especially steel sheets of mor thickness leave their traces. Imprecise folding and folding prints are pre-programmed.

Solution:

Westermann 24 delivers Dies with shafts of inlet. The ordinary tool with grinded and hardened shafts of inlet is going to be a carrier of tools. The segmentation of the tool is possible with the deployment of a one part shaft. The customer can change the shafts of inlet at place without high costs of system. The shaft inserts can be delivered additionally with a shaft fixing. In the case of the inserts is the deployment of different materials possible (for example Ampco against ferritistik abraision)

Advantages:

- less wear with shafts of inlet
- hardened, grounded Shafts of inlet CF53/60HRC
- less cost of tools by deployment
- Shafts of inlet changeable easy and quick by yourself
- Reducing the power of pressing
- Reducing the presses of edges

Halter und Einsätze



verschiedene Aufnahmen für OE-Einsätze / different admission for upper tool inserts



Welleneinsatz mit Nut / Shaft inserts with groove

Westermann24 liefert Ihnen Lösungen für Halter mit Einsatz.

Vorteile:

- Einsätze in gehärteter Ausführung sind möglich.
- Einsätze für höhere Presskräfte sind möglich.

Holder and inserts



Welleneinsatz rund in Prismenaufnahme / Shaft inserts round in prism take-ups



Welleneinsatz gehärtet geschliffen Cf53/HRC60 / Shaft inserts hardened and grinded Cf53/HRC60

Westermann24 delivers solutions for holder and inserts.

Advantages:

- Hardened inserts are possible.
- Inserts for higher press capacity are possible.

Brückenwerkzeug für geschlossene Profile

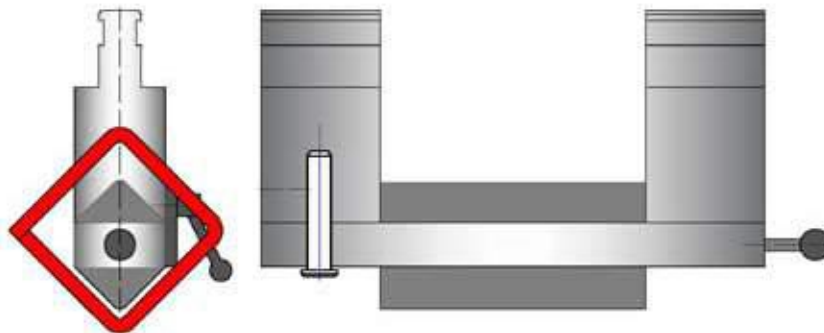

Unsere Lösung:

Westermann24 entwickelt für Sie ein Brückenwerkzeug, mit dem das gekantete geschlossene Profil durch den schwenkbaren Werkzeugeinsatz nach vorne entnommen werden.

Besonderheit:

Biegelänge 400mm für Kerneinsatz $t=10\text{mm}$ VA(700Nmm²)

Bridge-tool for closed profiles

Our solution:

Westermann24 develops a bridge- tool for you, which determine the possibility for a frontal removal of the profil because of the rotating tool.

Special feature:

bending length 400mm for core insert $t=10\text{mm}$ VA(700Nmm²)



3. Kantung / 3rd bending



Profil geschlossen / profile closed



Profil kann entnommen werden / profile can be collected

Sonderwerkzeug : zur Herstellung von Regal- böden

Special tools: to produce shelves



höchst Verschleißfestigkeit / high degree of wear resistance



Werkzeug mit durchgehärteten (HRC60) und polierten Einsätzen / tools with sufficiently hardness (HRC60) and polished issues

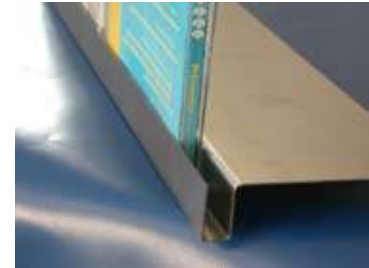

Profiltiefe / profile depth U=28x8mm

Problem:

- Das Profil ist in Einzelkantungen zu aufwendig herzustellen
- Der Regalboden darf aus fertigungstechnischen Gründen nur horizontal zugeführt werden .
- **Die Abschlusskante (3x90°) soll in einem Hub erfolgen .**
- Das Werkzeug soll für höchste Verschleißfestigkeit und hohe Stückzahlen konstruiert sein (durchgehärtete Einsätze).

Lösung:

- Westermann24 liefert seinem Kunden die komplette Lösung.
- Termin vor Ort (Problemerkennung) , Konstruktion , Angebot,
- Abnahme durch Probekantung oder Abnahme durch Einrichten vor Ort .

Problem:

- The production of the profile is too timeconsuming in one fold.
- Out of reasons of production technology, the shelves can be feed horizontal only.
- **The closing edge (3x90°) shall be done in one stroke.**
- The tool is constructed for a high degree of wear resistance and a high number of pieces (sufficiently issues).

Solution:

- Westermann24 delivers completely solutions to his customers .
- identification of the problem , construction , offer
- acceptance with samples of bending .

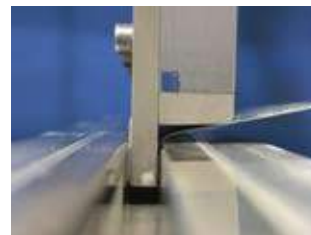
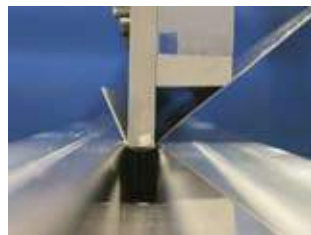
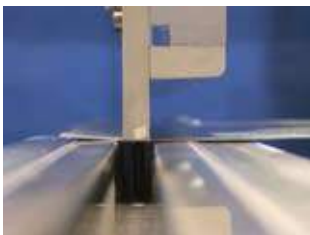

Rohrschellenwerkzeug

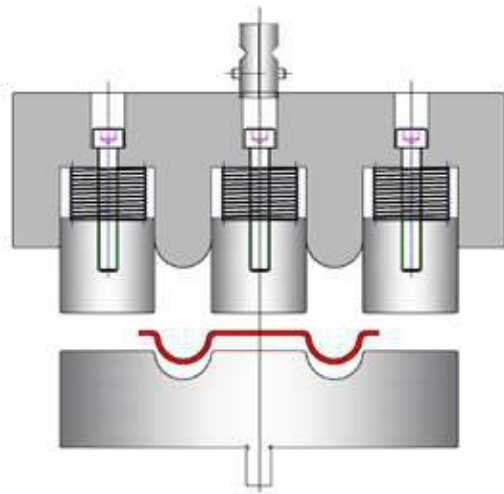

Unsere Lösung:

Westermann24 entwickelt ein Prägewerkzeug zur Herstellung der Rohrschelle in einem Hub..

Besonderheit:

Die Positionierung des Blechteils erfolgt über die Einzugschwinde im Blech. Dadurch kann das Blech gleichförmig und passgenau ausgeprägt werden.

Vorteil:

Westermann 24 liefert dem Kunden ein bereits erprobtes Werkzeug.

Die Werkzeugform ist bereits korrigiert.

Vor Auslieferung hat der Kunde bereits erste Musterbleche zu Begutachtung erhalten.

Tube clamps tool



Our solution:

Westermann24 develops an embossing-tool to enable the production of tube clamps in one stroke.

Special feature:

The positioning of the plate is working about the pulling-winch in the plate. Therefore it is possible to embossing the plate uniform and tailor-made.

Advantage:

Westermann 24 delivers a well proved tool to the customer.

The shape of the tool is ready adjusted.

Before the delivery stands the assesment from the sample panels from the customer.



...bewegliche Hörner ?

...moveable horns ?



geöffnetes Horn / horn kept open



geschlossenes Horn / closed horn



geschlossenes Blechprofil / closed plate profil

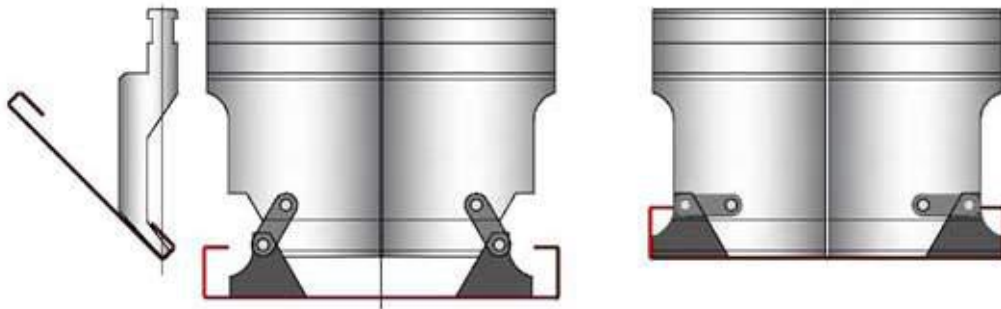

Lösung:

Westermann 24 liefert Ihnen Oberwerkzeuge mit beweglichen Hörnern.
Entweder fertig ab Lager, oder individuell für Sie gefertigt.

Besonderheit:

Die Hörner werden dabei so hergestellt, dass die Entnahme von allseitig gekante-
ten Blechen keine Probleme mehr bereitet.

Solution:

Westermann 24 delivers a upper tool with moveable horns.
Either ready from stock, or produced individual for you.

Special feature:

The horns will be produced in the way, that the removal of allside edging plates
is no problem



Versteifung Doppelfalz

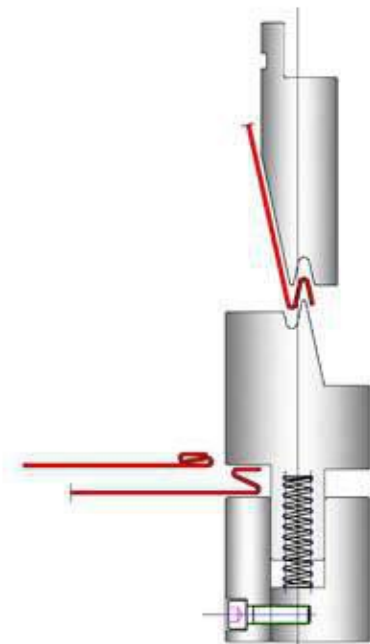

Unsere Lösung:

Westermann24 entwickelt ein Prägwerkzeug zur Herstellung des Profils in zwei Hüben.

Besonderheit:

Durch die Prägung im oberen Teil des Werkzeuges kann der gewünschte Doppelfalz nach Kundenwunsch hergestellt werden.

Vorteile:

Westermann 24 liefert dem Kunden ein bereits erprobtes Werkzeug. Die Werkzeugform ist bereits korrigiert. Vor Auslieferung hat der Kunde bereits erste Musterbleche zu Begutachtung erhalten.

Stiffening double seam



Our solution:

Westermann24 develops a embossing-tool for the production of the profile in two strokes.

Special feature:

Because of the embossing in the upper part of the tool the double seam can be produced, according to the wishes of the customers.

Advantage:

Westermann 24 delivers a well proved tool to the customer. The shape of the tool is redy adjusted. Before the delivery stands the assesment from the sample panels from the customer.



Schachtelwerkzeug

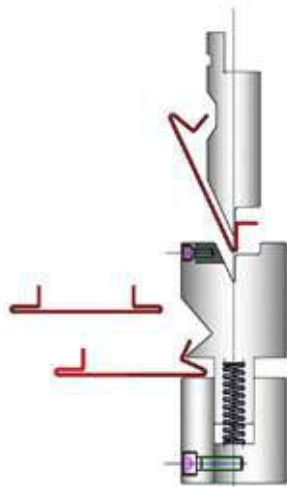

Unsere Lösung:

Westermann24 entwickelt ein Prägewerkzeug zur Herstellung des Profils in zwei Hieben.

Besonderheit: Das fertige Profil konnte anstelle von 6 Hieben durch Einsatz des Prägewerkzeuges im oberen Teil mit 4 Hieben hergestellt werden.

Vorteil:

Westermann 24 liefert dem Kunden ein bereits erprobtes Werkzeug.

Die Werkzeugform ist bereits korrigiert.

Vor Auslieferung hat der Kunde bereits erste Musterbleche zu Begutachtung erhalten.

Box tool



Our solution:

Westermann24 develops a embossing tool to produce profiles in two strokes.

Special feature:

The ready profile can be produced instead of 6 strokes, in 4 strokes by using the embossing tool in the upper part.

Advantage:

Westermann 24 delivers the customer a well proved tool.

The shape of the tool is ready adjusted.

Before the delivery stands the assesment of the sample panels of the customer



Wellblech , Prägwerkzeug mit Niederhalter

corrugated iron, embossing- tool and blank holder

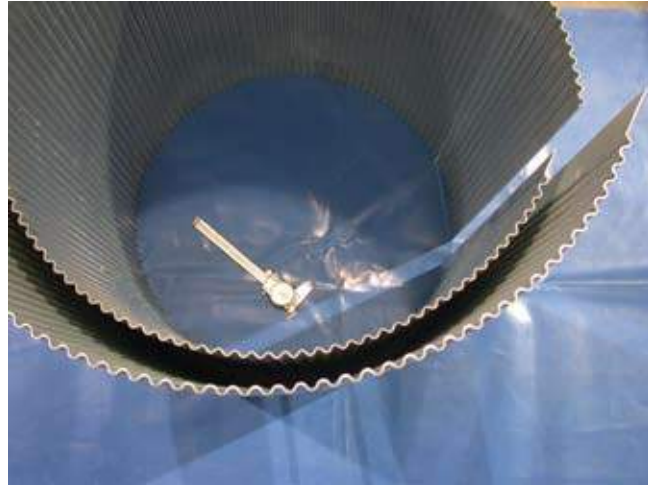
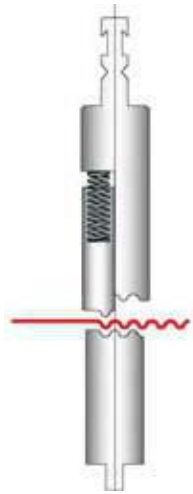

Unsere Lösung:

Westermann24 entwickelt ein Prägwerkzeug mit Niederhalter. Dabei wird das im ersten Hub geprägte Wellenprofil durch den Niederhalter im Werkzeug fixiert. Es wird dabei kein Anschlag mehr benötigt. Das nachfolgende Wellenprofil kann nun parallel zum vorherigen Profil geprägt werden.

Besonderheit:

Es entsteht ein gleichförmiges und maßhaltiges Wellblechprofil.

Vorteil:

Westermann 24 liefert dem Kunden ein bereits erprobtes Werkzeug. Die Werkzeugform ist bereits korrigiert. Vor Auslieferung hat der Kunde bereits erste Musterbleche zu Begutachtung erhalten.

Our solution:

Westermann24 develops an embossing- tool with blank holder. The embossed corrugated profil in the first hub is fixed by the blank holder in the tool. In this case a retractable is no more necessary. The following corrugated iron can be produced as like as the profile before.

Special feature:

It arises an uniform and proper dimensioned corrugated iron profile.

Advantage:

Westermann 24 delivers a well proved tool to the customer. The shape of the tool is ready adjusted. Before the delivery stands the assesment from the sample panels for the customer.



Einlegen der vorherigen Kantung /
inserting of the previous bending



Prägen des nachfolgenden Wellenprofils /
embossing of the following profil



Fertiges Wellenprofil / ready embossed
corrugated profil



Prägen des nachfolgenden Wellenprofils /
embossing of the following profil

Einrollwerkzeug

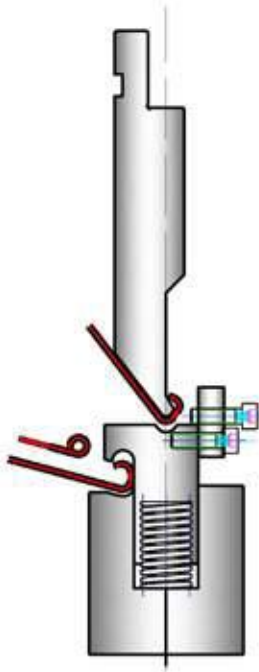

Die Herstellung des Profils erfolgt in drei Schritten:
 1.+2. Schritt: das Vorkanten der Abwicklungslänge
 3. Schritt: das Einrollen des Radius

Unsere Lösung:

Westermann24 liefert Ihnen Einrollwerkzeuge zur Herstellung von Scharnieren oder runder Kanten wie Sitzbänken oder Rinnen . Die Werkzeuge werden für verschiedene Radien, Blechstärken und Materialien hergestellt. Dabei wird die Blechstärke und das zu kantende Material bezüglich der Rückfederung berücksichtigt.



Scharnier mit Innendurchmesser 8mm / hinges with inner diameter 8mm

Roll-in tool



The production of the profile is based in three steps:
 1.+2. steps: the preliminary edging of the roll out length
 3. step: the rolling in of the radius

Our solution:

Westermann24 delivers a roll in tool for the production of hinges or round edges as like benches or channels. The tools are produced for different radii, plate thickness and materials. The plate thickness is important because it has to be considered according the rebound.

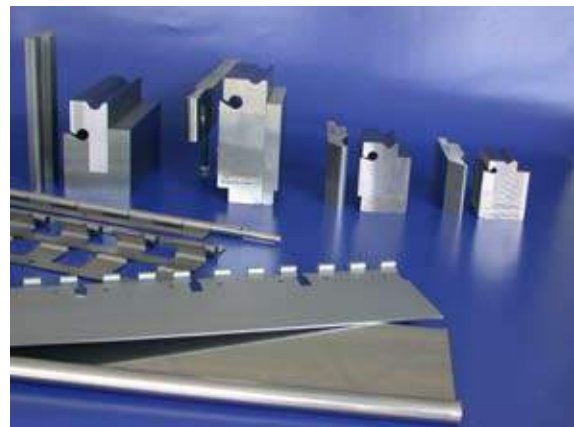

Einrollwerkzeuge in verschiedenen Größen / Roll in tools in different sizes

Schwenbakenwerkzeug mit Positionierung und Formschluss

Panning jaws tool with exact positioning and form locking

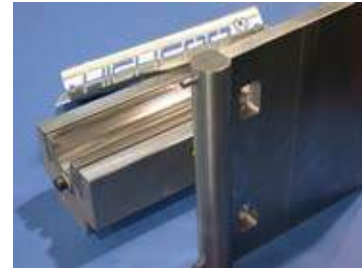
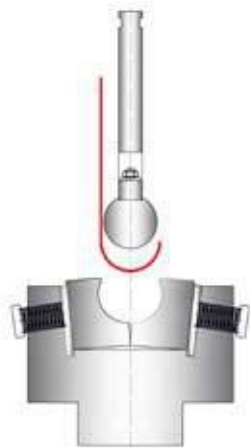

Unsere Lösung:

Westermann 24 entwickelt ein Schwenbakenwerkzeug mit Formschluss, welches in einem Hub das gewünschte Profil erzeugt. Das Blech wird über einen Positionierstift beim Kantvorgang gehalten. Beim Überbiegen des Blechprofils wird gleichzeitig ein Formschluss geprägt, der ausgeknickte Buchstaben zum gewünschten Radius angleicht.

Besonderheit:

Das Profil soll in einem Hub hergestellt werden. Der vorher eingebrachte Schriftzug befindet sich auf der Biegelinie. Teilbereiche einiger Buchstaben würden bei einer „freien Biegung“ aus dem gebogenen Radius herausstehen. Zusätzlich soll der Schriftzug beim Biegevorgang nicht verrutschen.

Vorteil:

Westermann24 liefert Ihnen ein bereits erprobtes Werkzeug. Das Werkzeug ist bereits korrigiert. Vor Auslieferung der Werkzeuge hat der Kunde erste Musterbleche zur Bemusterung erhalten.

Solution:

Westermann 24 develops a panning jaws tool with form locking, which is producing the required profile in one stroke. The metallic sheet is moved over the positioning pin while the edging process. While the overbending of the metallic sheet simultaneously it is stroking a form locking, which is adapt the beeing buckled out letter to the desired radius.

Special feature:

The profil should be produced in one stroke. The writing which has been introduced before is now on the bendline. In the case of a free bending individuell sections of some letters will be look out of the bended radius. Additionally while the bending process the writing shall be at the same place.

Advantage:

Westermann24 delivers a well proved toll to the customer. The shape of the tool is ready adjusted. Before the delivery stands the assesment from the sample panels from the customer.



Stationswerkzeug:

1. Hub = Schwenkbackenwerkzeug
2. Hub = Absetzwerkzeug

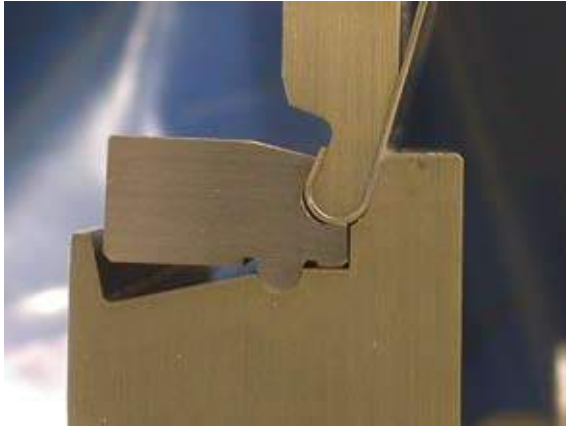

überbiegen des Radius in einem Arbeitsgang / overbending of the radius in one step

Problem:

Die Herstellung eines Blechprofils, welches sonst in 4 Hieben hergestellt wurde, soll verbessert werden. Zusätzlich besteht das Problem, dass die Abwicklungslänge beim Biegen des 180° Radius an der Oberwange anschlägt.

Lösung:

Westermann 24 entwickelt ein Schwenkbackenwerkzeug, welches in einem Hub den Radius inklusive Überbiegung herstellt, ohne dass die Anwicklungslänge des Bleches am Oberwerkzeug anschlägt, und dadurch verbogen wird. Im 2. Arbeitsgang wird durch ein Absetzwerkzeug die Z-Stufe in einem Arbeitsgang geprägt.

Beide Werkzeuge werden als Stationswerkzeug in der Höhe aufeinander abgestimmt. Somit lässt sich das Blechprofil in einem Arbeitsgang herstellen, ohne dass es zwischenzeitlich aus der Hand gelegt werden muss.

Vorteile:

Durch den Einsatz von Westermann - Werkzeugen, konnte die Herstellungszeit für das Blechprofil um mehr als 50% reduziert werden. Eine weitere Zeiteinsparung wurde durch den Aufbau als Stationswerkzeug erzielt.

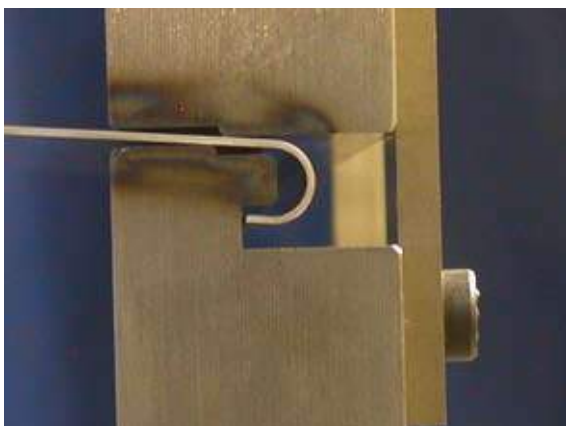

Station tool:

1. stroke = Swivel-clip- tool
2. stroke = set down-tool

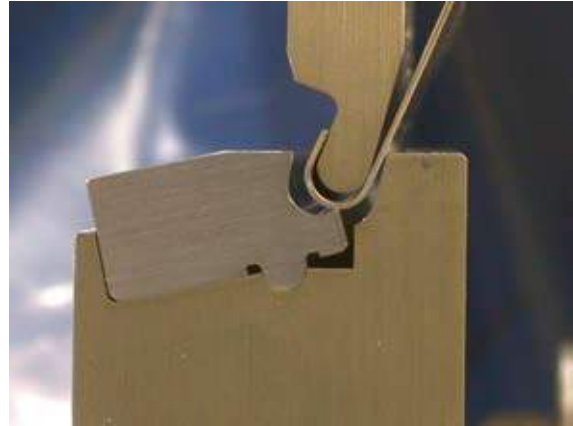

das Blechprofil schlägt dabei nicht am Oberwerkzeug an / the steel sheet don't contact the upper tool

Problem:

The production of a profile out of a metallic sheet, which has been produced in 4 strokes, should be improved. Additionally there is the problem: The length of the material gets contact with the upper tool by the bending process till 180° radius

Solution:

Westermann 24 develops a Schwenkbacken-tool, which creates in one stroke the radius inclusive overbending, without contacting with the length of the sheet the upper tool and without not desired bendings. In the second process will be made the embossing process of the Z-step by a set down-tool.

Both tools will be as station- tools in the highness coordinated. So the profile will be produced in one working step, without disruption.

Advantage:

Because of the deployment of Westermann - tools, the time for production has been reduced for the profile by 50%. A further time saving is possible within the building up of the station-tool.

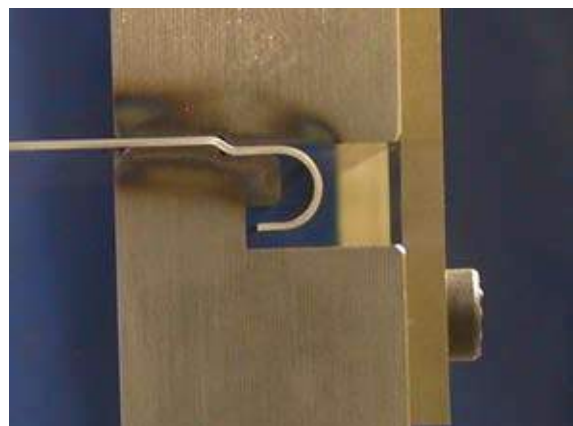

Prägwerkzeug für Reflektorblech

Stamping tool for reflector sheets



Problem:

Der Radienverlauf des Blechprofils ist eine schräg gestellte Ellipse, die unter einem bestimmten Winkel und Abstandsmaß reflektieren soll. Alle Maße im Bezug zu den Positionsbohrungen im Reflektorblech. Die Spiegelfläche muss fließendes Licht projizieren und darf keinerlei Abdruck aufweisen.

Lösung:

Westermann24 setzt ein säulengeführtes Werkzeug mit Kunststoffeinsatz ein. Das Prägeprofil wird durch eine vollprofilierte Schleifscheibe maßgenau bezüglich der Rückfederung erzeugt.

Ergebnis: 1xHub = 1Teil

Problem:

The art of the radii of the profile of steel is a slanting placed ellipse, which shall be reflecting in a determined angle and distance dimension. All distances according to the positioning holes in the area of the reflector sheet. The reflector surface have to produce fluid light and there cannot be any print on it.

Solution:

Westermann24 uses a column-guides tool with plastic-inserts. The embossing profile is going to be produced by a profiled grinding wheel accuracy according of the spring back.

Result: 1xHub = 1Teil

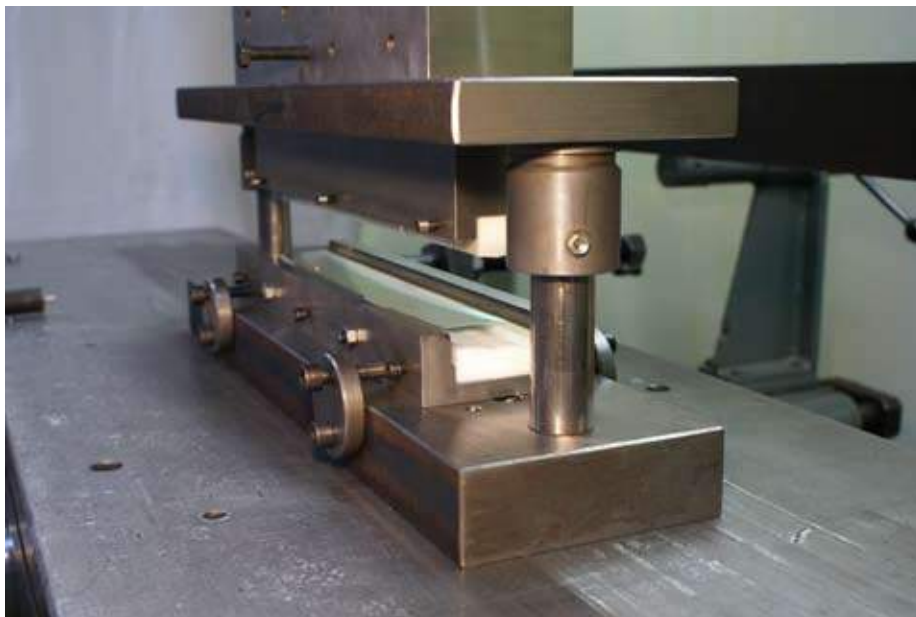

Werkzeuiglösung für verkröpftes Z-Profil



Frei tragender Niederhalter / cantilever blankholder

A tool-solution for a cranked Z- profil

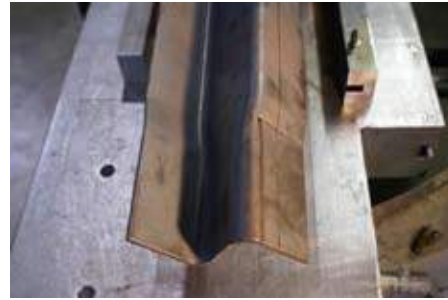

Verkröpftes Z-Profil / cranked Z-profil

Unsere Lösung:

Ein Doppelhubwerkzeug hält zwischen zwei frei tragenden Niederhaltern das Z-Profil gegen Verdrehung fest. Im Ausprägen werden die beiden Profilenden in einem Hub zum bestehenden Z-Profil abgesetzt bzw. verkröpft. Durch verschiedene Prägeeinsätze werden unterschiedliche Profilendstücke erzeugt.

Our solution:

A double-stroke tool is fixing a Z- profile between two cantilever blankholder against distortion. Both profil endings are deposed especially cranked in one stroke to the existing Z- profile. With differrent embossed inserts will be produced differrent endpieces of profiles.



Nachschleifen / Neufertigung / Scherenmesser

Nachschleifservice und Neufertigung bis 6500mm/einteilig

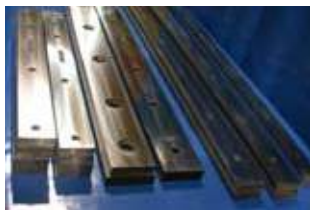

Neufertigung / New production

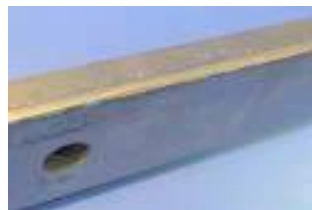

Scherenmesser zum Nachschleifen/ shearingknives for regrinding



schleifen bis 6500mm / grinding till 6500mm

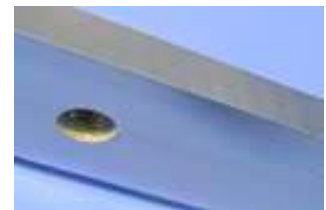

Scherenmesser nachgeschliffen / shearingknives regrinded

Regrinding / New production / Shearingknives

Regrinding service and new production till 6500mm/ one piece made

Nachschleifen-Lieferzeit :

zum vereinbarten Termin sofort (z.B.: 6 Uhr Anlieferung , 12 Uhr Abholung)

Neufertigung:

Westermann24 fertigt für Sie Scherenmesser mit kontinuierlich hoher Qualität . Dabei berücksichtigen wir Ihre besonderen Wünsche (zu schneidendes Material , Härte, Standfestigkeit...) oder auch Sonderwünsche .

Delivery-period for regrinding:

immediately to the agreed date (as usual: 6 o' clock on delivery , 12 o' clock pick up)

New production:

Westermann24 produces shearingknives with a high quality result every day for you. Further your individual wishes should be considered (Material to be cut , hardness , resistance...) or special requests too.

Komplett-Sonderlösung von / Custom Solutions individualy by Westermann24:



Blue Line

Werkzeuiglösung für Falz mit 90°



A tool solution for folding with 90°

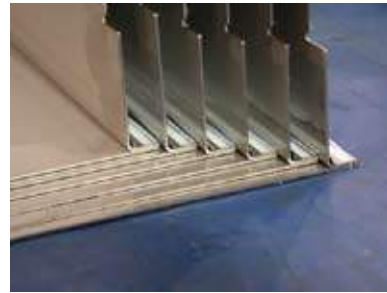

Unsere Lösung:

Ein Falzwerkzeug mit Ausprägung der angrenzenden 90° Kantung.

Besonderheit:

Der Falz wird mit dem gleichen Werkzeug zgedrückt.
2x Hub..., fertig.

Our solution:

A folding tool with tangential expression of the 90° bending.

Special feature:

The fold can be shut with the same tool.
2 x stroke..., ready.

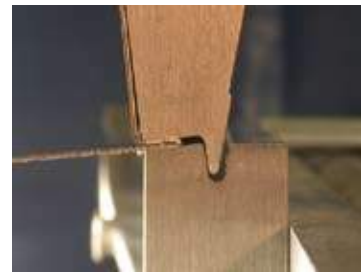
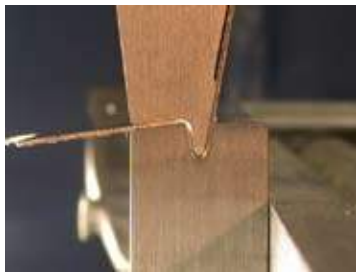

Schwenkbackenwerkzeug

Panning -jaws-tool

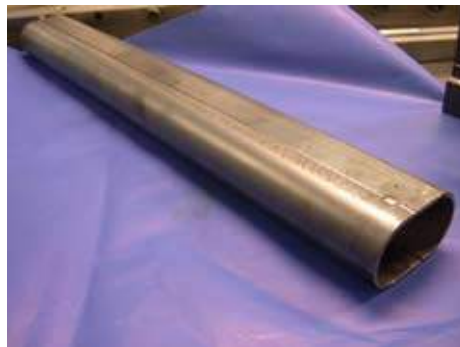

Flachrohr 100x65/Blechstärke 6mm / flat-tube 100x65/
metal-thickness 6mm

Unsere Lösung:

Für das Flachrohrprofil wurde ein Schwenkbackenwerkzeug eingesetzt.
Die Biegewinkel müssen parallel sein, um als Halbschale verschweißt werden zu können.

Our solution:

For the production of the flat-tube-profile was used a panning-jaws-tool.
The bending angle have to be paralel to enable the welding as a half shell.



Eiskartenhalter geschlossenes Profil

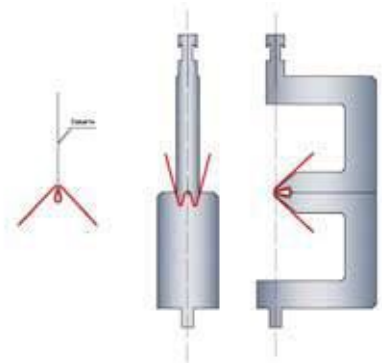

Unsere Lösung:

Westermann24 entwickelt ein Stationswerkzeug zur Herstellung des Profils in zwei Hieben.
Die Werkzeuge sind höhengleich abgestimmt und nebeneinander auf der Abkantpresse aufgebaut.
Der Kartenhalter kann somit in einem Durchgang hergestellt werden.

Besonderheit:

Es handelt sich um ein geschlossenes Profil.

Vorteil:

Westermann 24 liefert dem Kunden ein bereits erprobtes Werkzeug.
Die Werkzeugform ist bereits korrigiert.
Vor Auslieferung hat der Kunde bereits erste Musterbleche zu Begutachtung erhalten.

Mapholder closed profile

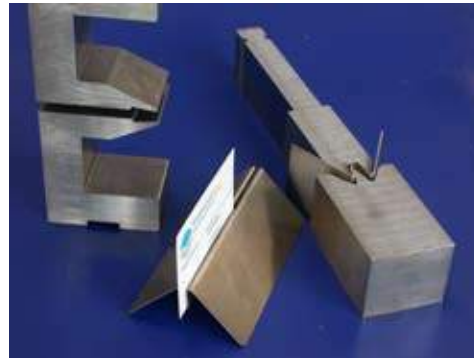

Our solution:

Westermann24 has been developed a Stationswerkzeug for producing the profiles with two strokes.
The tools are at the same level coordinated and are build up stowed side by side at the press brake.
So it is possible to produce the mapholder in one session.

Special feature:

It is an closed profile.

Advantage:

Westermann 24 delivers a well proved tool for the customer.
The shape of the tool is ready adjusted.
Before the delivery stands the assessment from the sample panels of the customer.



Fertigung: 5 Stück Kartenhalter pro Hub / 5 pieces mapholder per stroke



Prägwerkzeug: Vorkanten / stampingtool: Preliminary edging



Zudrücken des geschlossenen Profil / pressing the closed profile

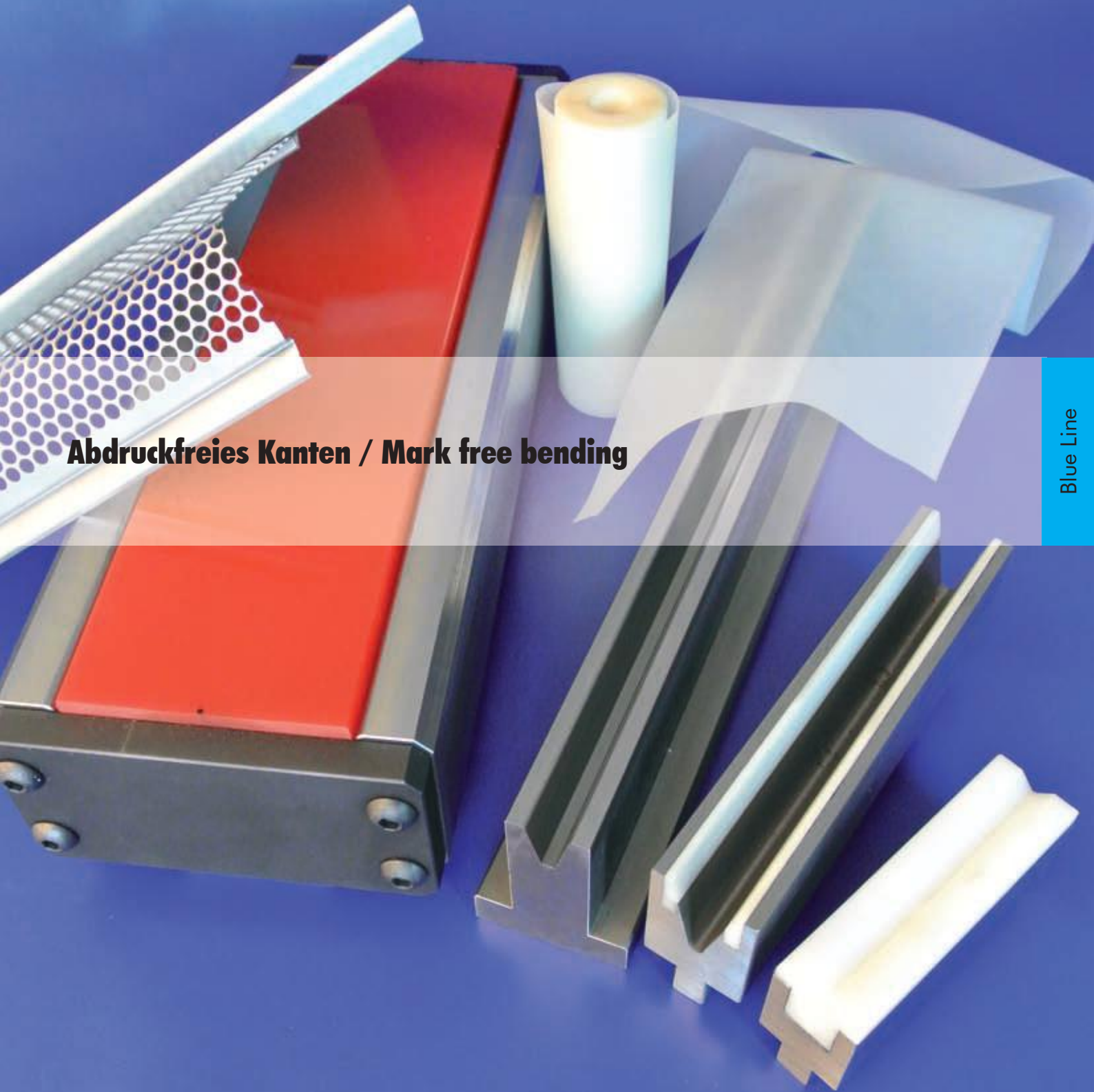

Abdruckfreies Kanten / Mark free bending

Blue Line

415 mm

835 mm

20.271

PU-Aufnahme - Urethane holder

415 mm

835 mm

	Shore
34.180	80A
34.190	90A
34.195	95A

PU-Polster - Urethane

415 mm

835 mm

	Shore
35.180	80A
35.190	90A
35.195	95A

PU-Polster mit Kernloch - Urethane with hole

415 mm

835 mm

20.272

PU-Aufnahme - Urethane holder

415 mm

835 mm

	Shore
34.280	80A
34.290	90A
34.295	95A

PU-Polster - Urethane

415 mm

835 mm

	Shore
35.280	80A
35.290	90A
35.295	95A

PU-Polster mit Kernloch - Urethane with hole

415 mm

835 mm

20.273

PU-Aufnahme - Urethane holder

415 mm

835 mm

	Shore
34.380	80A
34.390	90A
34.395	95A

PU-Polster - Urethane

415 mm

835 mm

	Shore
35.380	80A
35.390	90A
35.395	95A

PU-Polster mit Kernloch - Urethane with hole

415 mm

835 mm

20.274

PU-Aufnahme - Urethane holder

415 mm

835 mm

	Shore
34.480	80A
34.490	90A
34.495	95A

PU-Polster - Urethane

415 mm

835 mm

	Shore
35.480	80A
35.490	90A
35.495	95A

PU-Polster mit Kernloch - Urethane with hole

Modifikation PU-Aufnahme

Modification of urethane holder

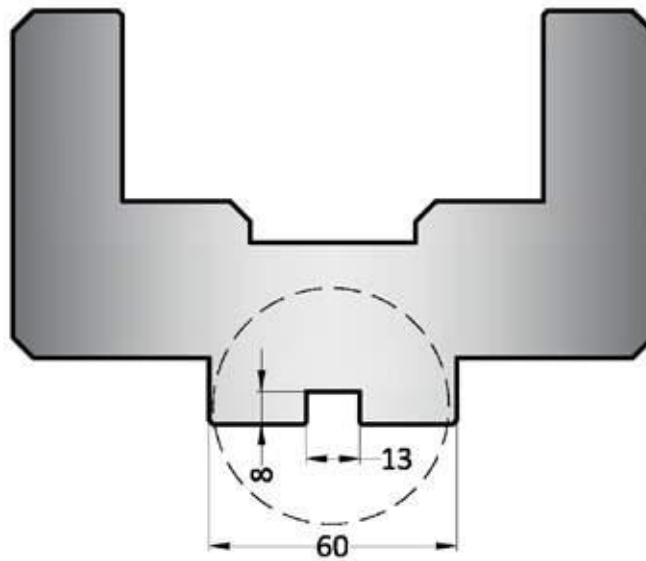

Modifikation der Aufnahme (Artikel 20.271, 20.272, 20.273 und 20.274) mittels Adaptern einsetzbar auf allen Abkantpressen.

Adapter siehe Seite 195

Modification of the urethane holder (Article 20.271, 20.272, 20.273 and 20.274) with the use of an adapter suitable for all types of press brakes.

Adapter see page 195

Abkantfolie

A metal foil for bending



Artikelnr. (A x B)	Länge
VU 0,4 x 102	30m
VU 0,4 x 152	30m
VU 0,55 x 100	30m
VU 0,55 x 200	30m
VU 0,8 x 102	30m
VU 0,8 x 152	30m
VU 2,0 x 150	50m

Kunststoffeinsätze

Westermann24 bietet Ihnen einen besonderen Kunststoff, der sich durch Härte und besondere Gleitfähigkeit auszeichnet.

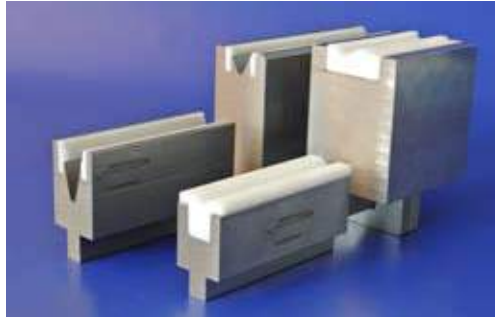

Das Ergebnis:

- Einwandfreie Funktion ohne Kantabdruck
- Hervorragende Winkelgenauigkeit durch eingepressten Kunststoff



Einwandfreie Funktion ohne Kantabdruck. / faultless function without edge pressings.

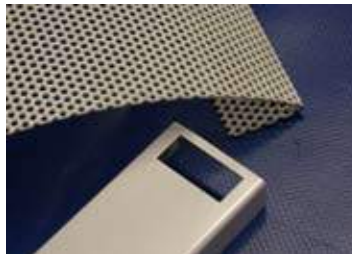

Kunststoffeinsätze

Westermann24 offers you an extraordinary plastic material, which is distinguished of hardness and a special sliding ability.

The result:

- Ensuring faultless functioning without edge pressings
- Excellent angle precision by pressed in plastic



Auch bei Prägewerkzeugen ohne Abdruck / with embossing tools, too

Matrize aus Ampco verhindert ferritischen Abrieb

The die out of Ampco prevents ferritic abrasion

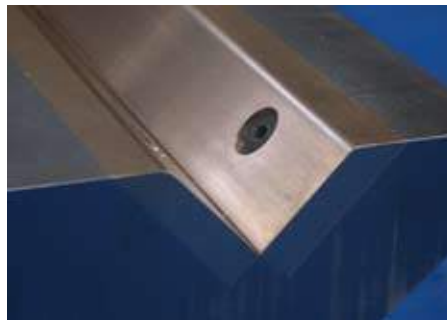

Zugfestigkeit bis 630 N/qmm.
Hohe Härte bei geringer Bruchdehnung. Sehr hohe Druckfestigkeit und mechanische Verschleißbeständigkeit.

Tensile force till 630 N/qmm . High hardness with less elongation of break. Very high compressive strength and mechanical abrasion resisting quality.

Merkmale:

- Abkantwerkzeuge aus Ampco verhindern den ferritischen Abrieb auf Edelstahlblechen die für die Lebensmittelindustrie benötigt werden .
- Dadurch entfällt kostenaufwendige Nachbearbeitung an den Blechen .

Characteristics:

- press brake tooling out of Ampco prevent the ferritic abrasion on sheets of stainless steel for the industry of food.
- Therefore disappears expensive refinishing at the sheets.

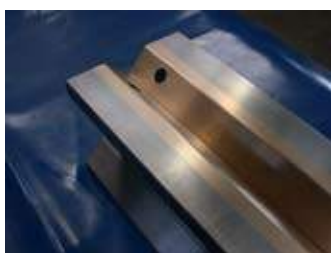

Ampco - Einsätze für Blockmatrizen oder auch für Steckmatrizen / Ampco - Deployment for block dies or plug-in dies too

Adapter / Adapters (S. 182-193)
Matrizen mit Einlaufwellen / Roller dies (S. 194-195)
Schwenkbiegewerkzeuge / Folding tools (S. 196-206)
Blockmatrizen / Block dies (S. 207-210)
Verstellbare Matrizen / Adjustable dies (S. 211-218)
Flexo (S. 219-222)
VARIO (S. 223-224)

	L	T/mt	Mt
60.680	2100	100	I
60.681	2600	100	I
60.682	3100	100	I
60.683	4100	100	I

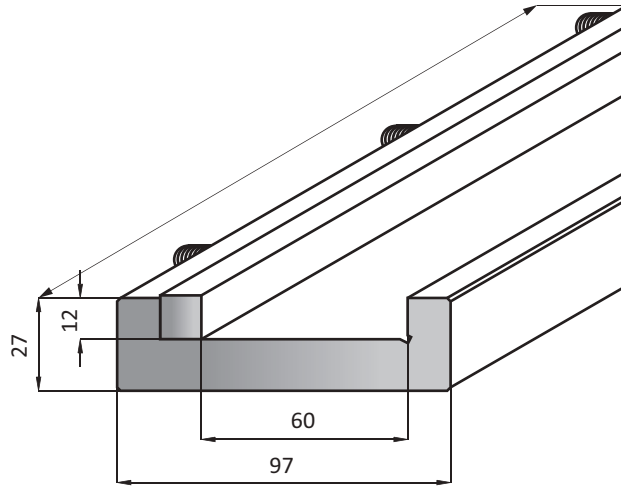

Halter -Holder

	L	H	T/mt	Mt
50.430	150	67.00	100	I

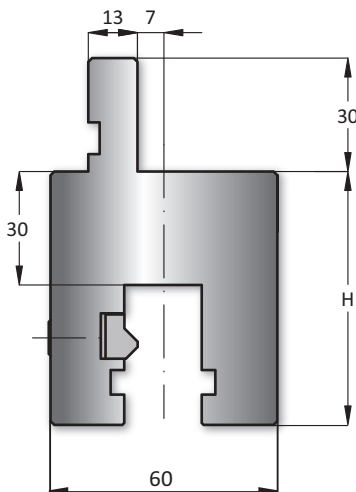
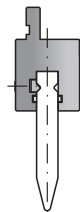

Amada/Wila Adapter

	L	H	T/mt	Mt
50.980	150	67.00	100	I

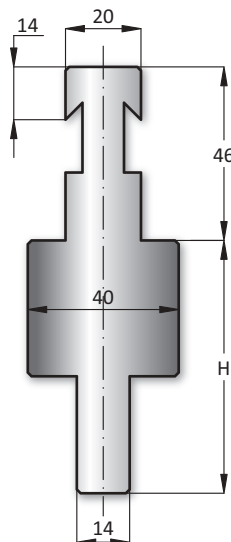
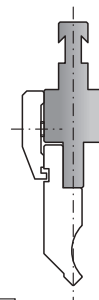

Beyeler-R Adapter

	L	H	T/mt	Mt
50.981	150	67.00	100	I

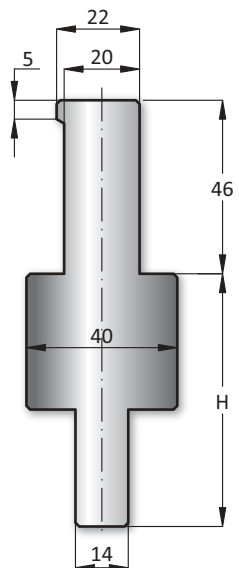

Beyeler-S Adapter

	L	H	T/mt	Mt
50.983	150	100.00	100	I

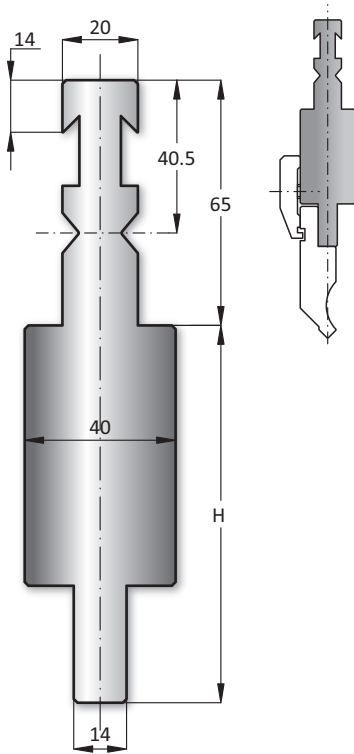

Beyeler RFA Adapter

	L	H	T/mt	Mt
50.970	150	80.00	100	I

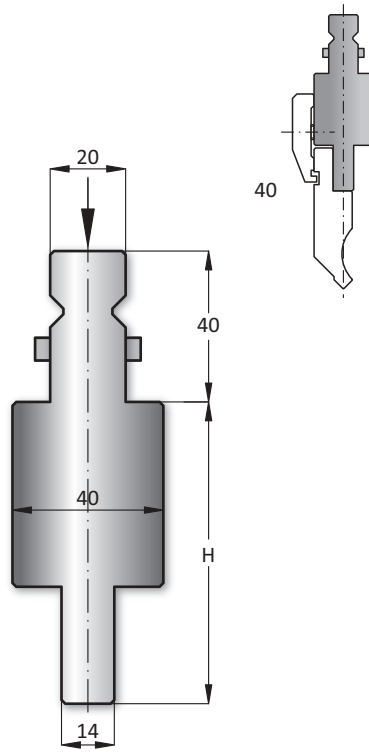

Wila/Trumpf Adapter

	L	H	T/mt	Mt
50.990	150	80.00	100	I

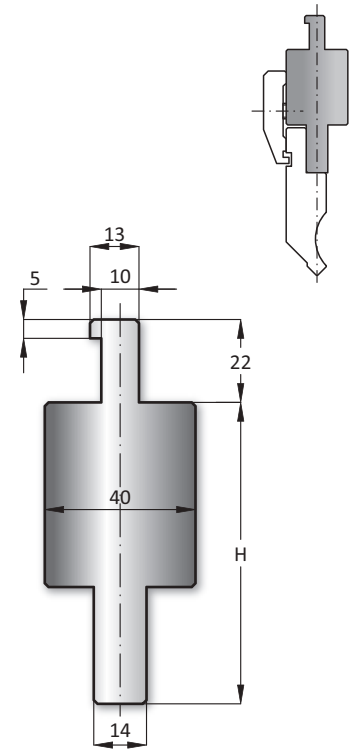

LVD Adapter

	L	H	T/mt	Mt
50.470	150	65.00	100	I

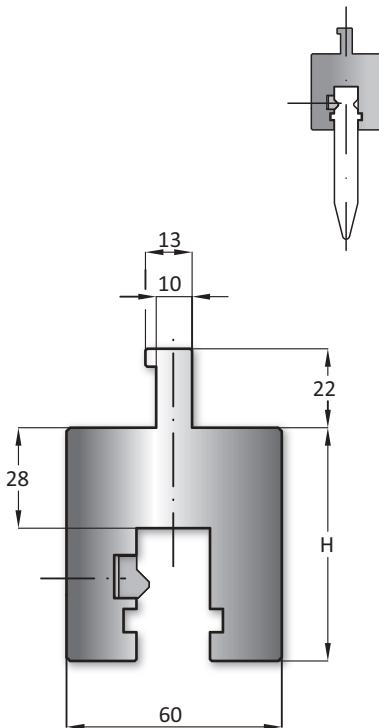

LVD/Wila-Trumpf Adapter

	L	H	T/mt	Mt
50.991	150	100.00	100	I

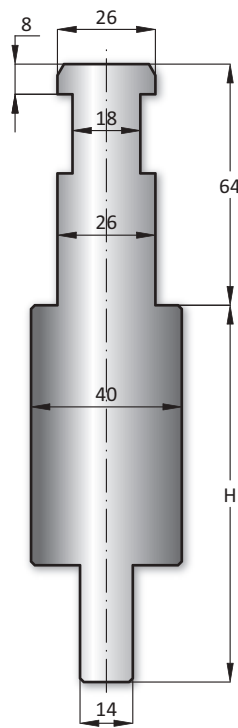

EHT Adapter

	L	H	T/mt	Mt
50.450	150	63.00	100	I

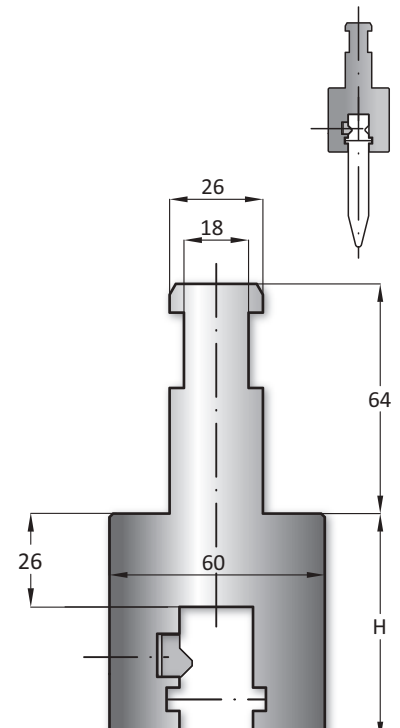

EHT/Wila-Trumpf Adapter

	L	H	T/mt	Mt
50.993	150	100.00	100	I

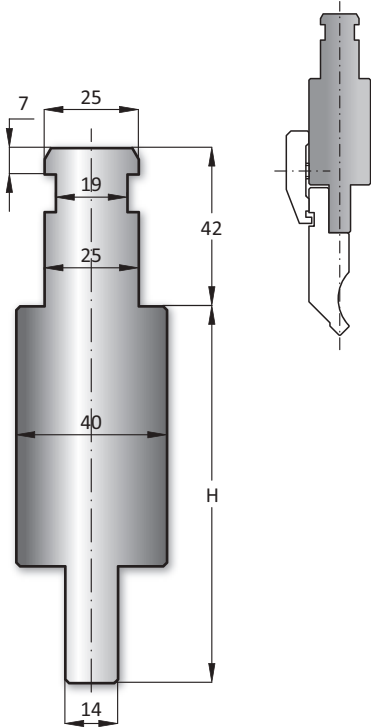

Weinbrenner Adapter

	L	H	T/mt	Mt
50.490	150	65.00	100	I

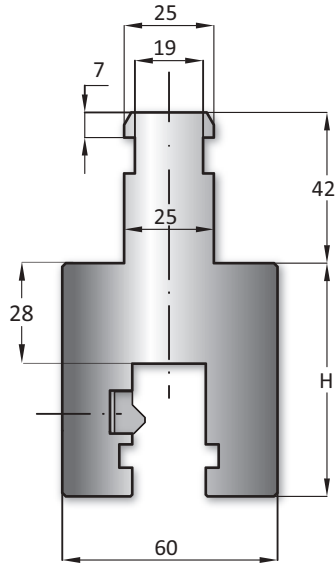

Weinbrenner/Wila-Trumpf Adapter

	L	H	T/mt	Mt
50.992	150	67.00	100	I

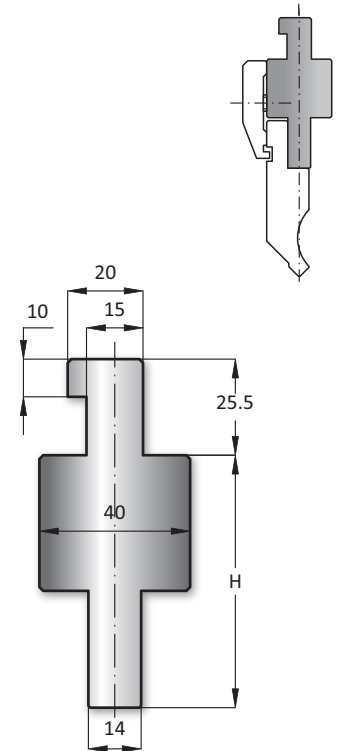

Durmazlar Adapter

	L	H	T/mt	Mt
50.996	150	89.00	100	I

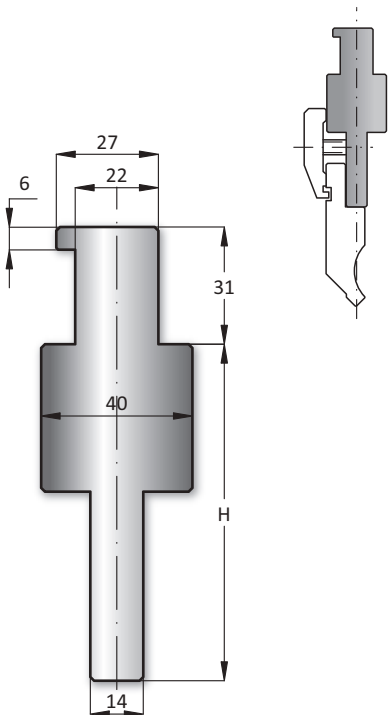

Baykal Adapter

	L	H	T/mt	Mt
50.998	150	67.00	100	I

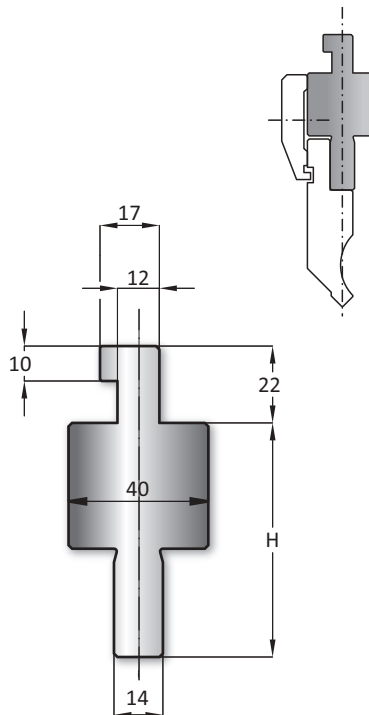

Haco Adapter

	L	H	T/mt	Mt
50.997	150	67.00	100	I

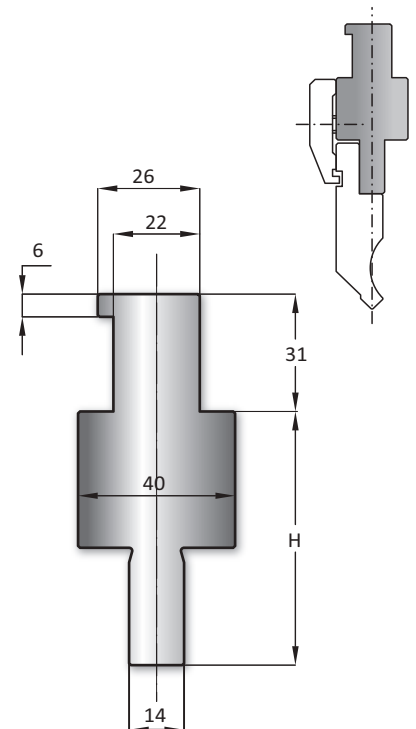

Darley Adapter

Black Line

	L	H	T/mt	Mt
50.994	150	100.00	100	I

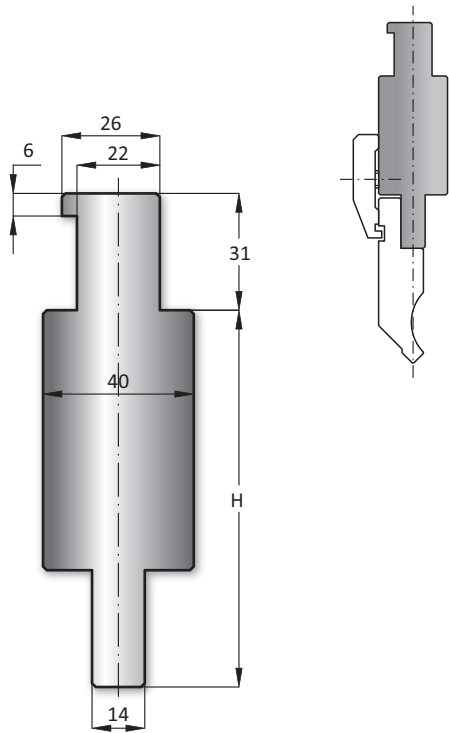

Darley Adapter

	L	H	T/mt	Mt
50.671	150	100.00	100	I

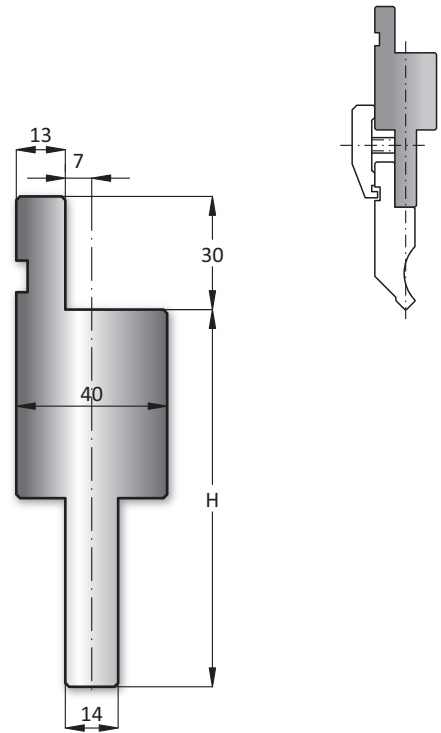

Verlängerung - Extension

	L	H	T/mt	Mt
50.959	150	60.00	100	I

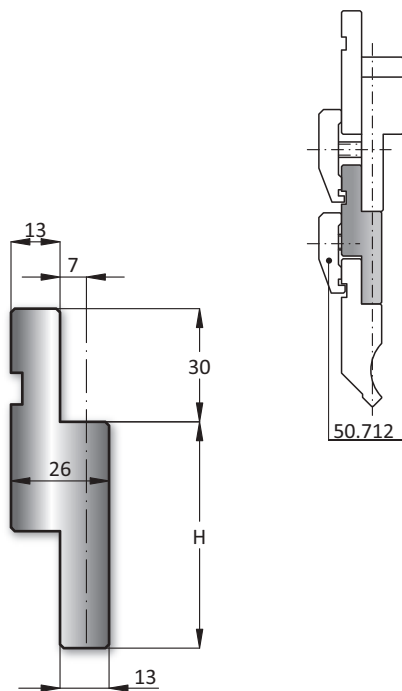

Verlängerung - Extension

	L	H	T/mt	Mt
50.985	150	100.00	100	I

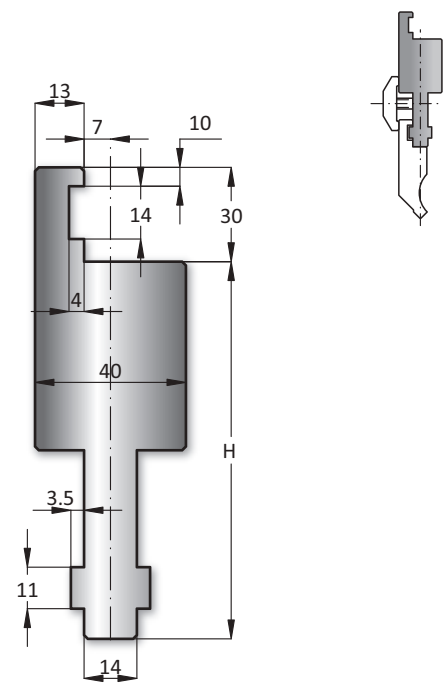

Verlängerung Beyeler - Extension Beyeler

	L	H	T/mt	Mt
50.982	150	101.00	100	I

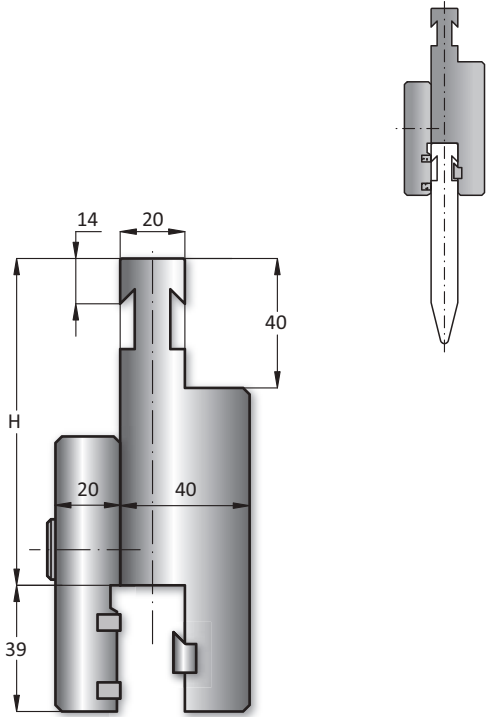

Verlängerung Beyeler-R - Extension Beyeler-R

	L	H	T/mt	Mt
50.400	150	100.00	100	I

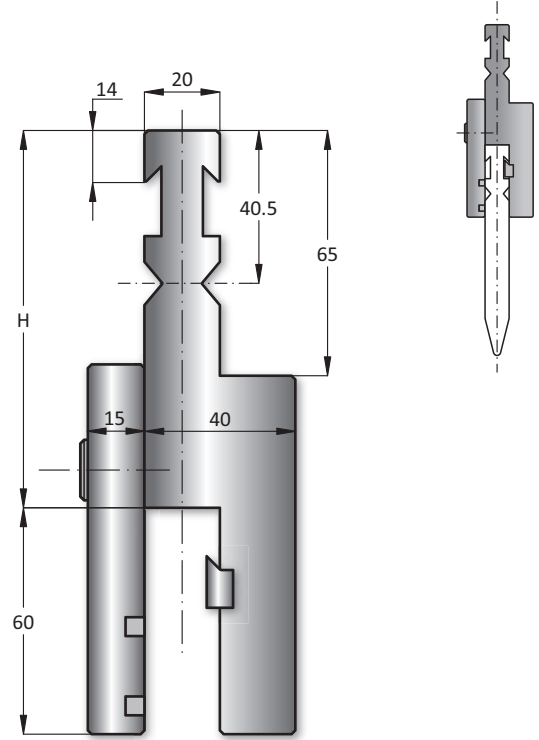

Verlängerung Beyeler RFA - Extension Beyeler RFA

	L	H	T/mt	Mt
50.410	150	100.00	100	I

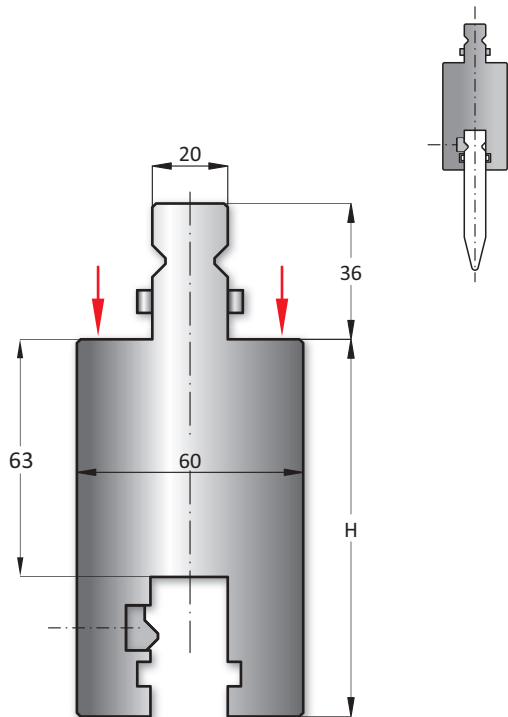

Verlängerung Wila-Trumpf - Extension Wila-Trumpf

	L	H	T/mt	Mt
50.415	50	100.00	100	I

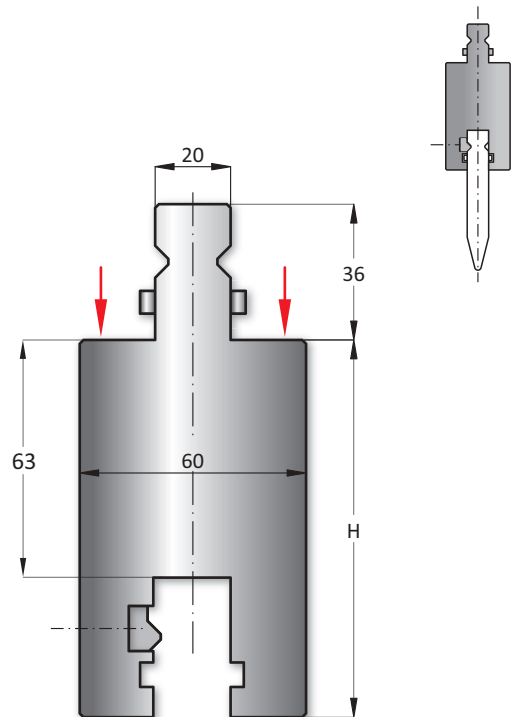

Verlängerung Wila-Trumpf - Extension Wila-Trumpf

	L	H	T/mt	Mt
50.445	50	150.00	100	I

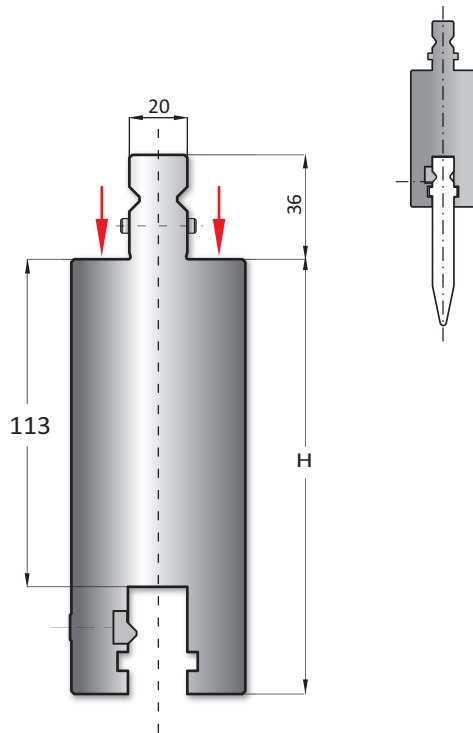

Verlängerung Wila-Trumpf - Extension Wila-Trumpf

	L	H	T/mt	Mt
50.440	150	150.00	100	I

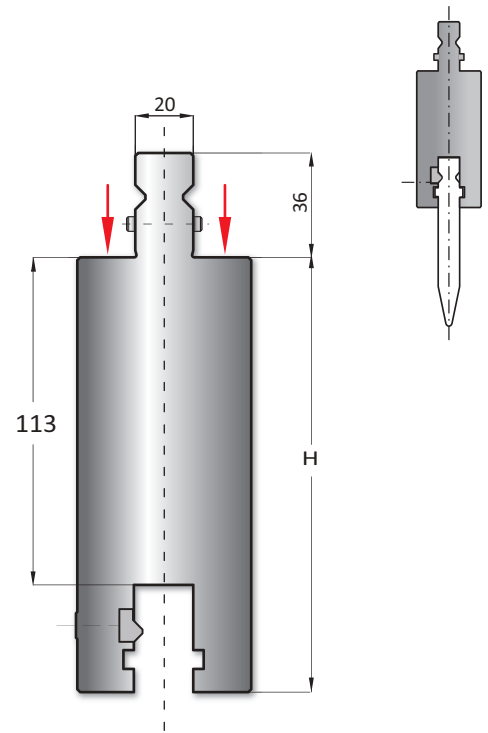

Verlängerung Wila-Trumpf - Extension Wila-Trumpf

	L	H	T/mt	Mt
50.500	200	220.00	90	I

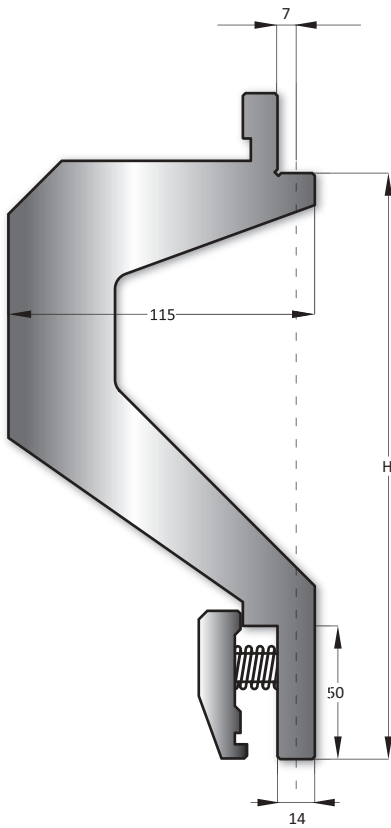
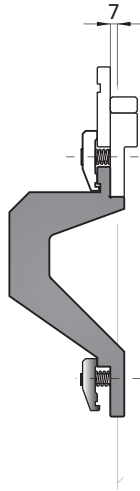

Verlängerung Amada - Extension Amada

	L	H	T/mt	Mt
50.501	200	220.00	90	I

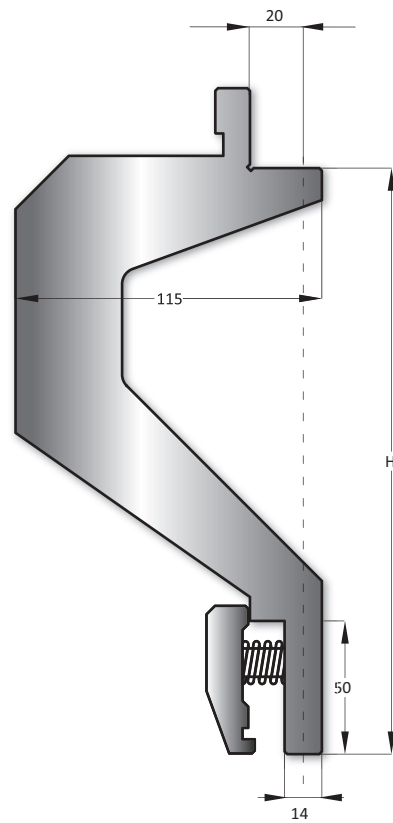
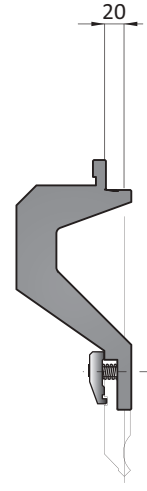

Verlängerung Amada - Extension Amada

Black Line

	L	H	T/mt	Mt
50.502	200	220	90	1

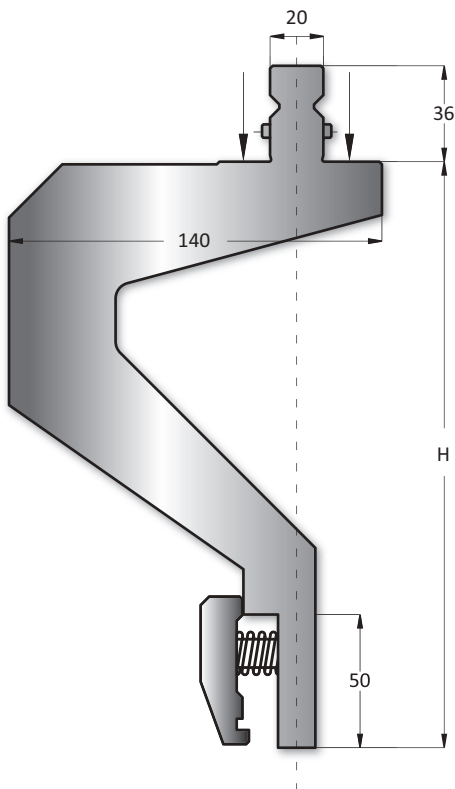
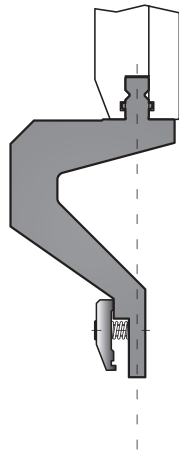

Wila-Trumpf Adapter

	L	H	T/mt	Mt
50.503	200	220.00	90	1

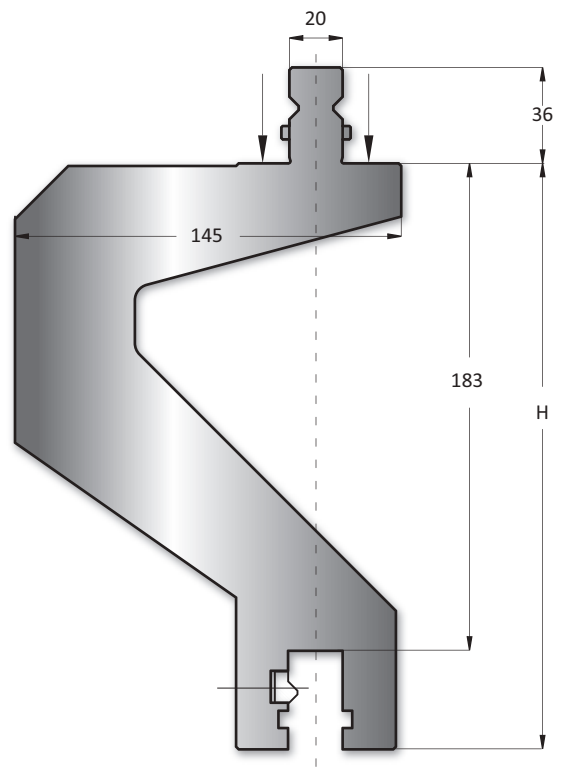
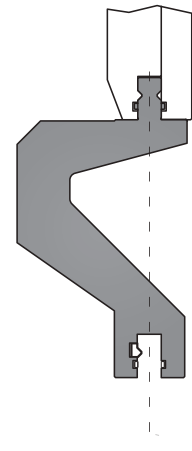

Wila-Trumpf Adapter

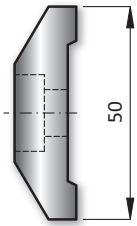

50.529

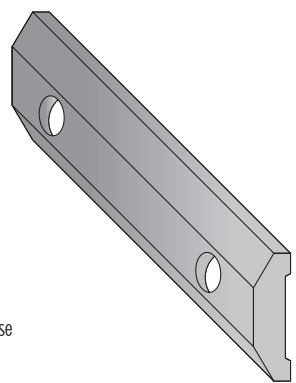

Spannvorrichtung ohne Sicherheitsnase
Clamp plate

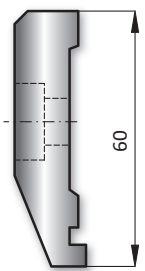

50.571

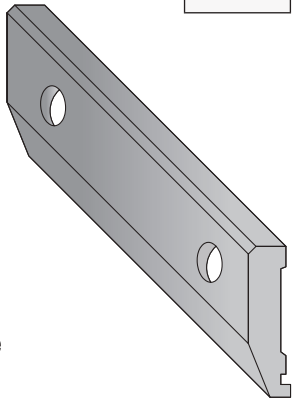

Spannvorrichtung mit Sicherheitsnase
Safety clamp plate

50.910

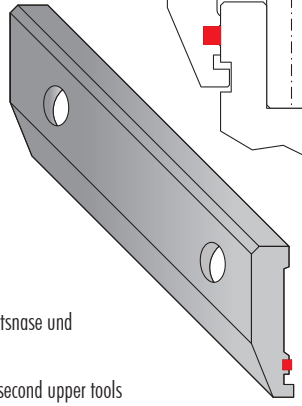
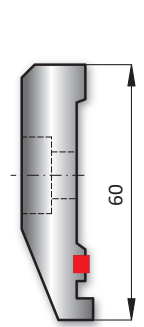

Spannvorrichtung mit Sicherheitsnase und Kunststoffandruckleiste
Safety clamp plate with pu for second upper tools

Mechanische Schnellspannvorrichtung mit Sicherheitsnase
Quick safety clamp plate

50.551

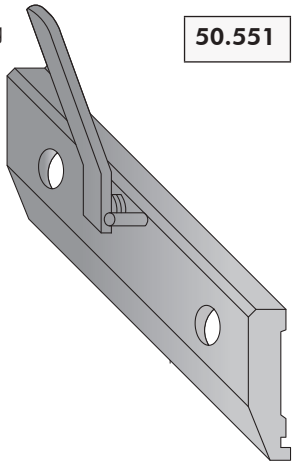
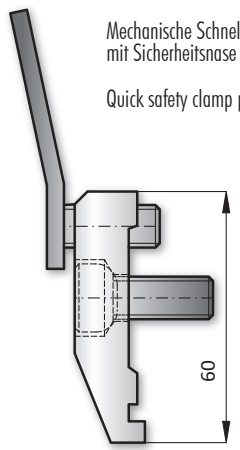

50.905

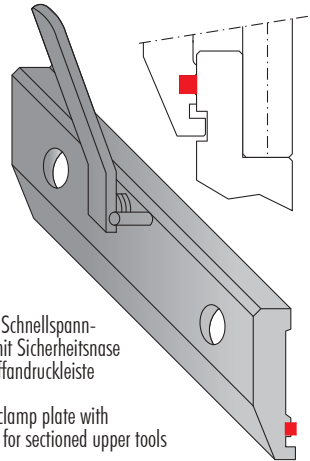
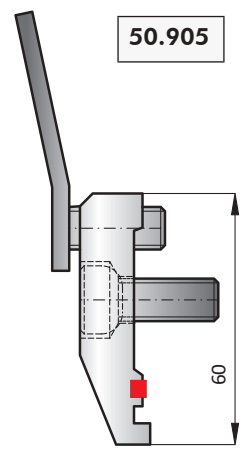

Mechanische Schnellspannvorrichtung mit Sicherheitsnase und Kunststoffandruckleiste
Quick safety clamp plate with polyurethane for sectioned upper tools

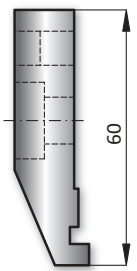

50.900

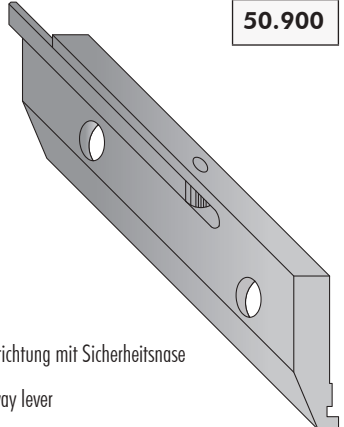

Mechanische Schnellspannvorrichtung mit Sicherheitsnase
Quick clamp plate with foldaway lever

50.903

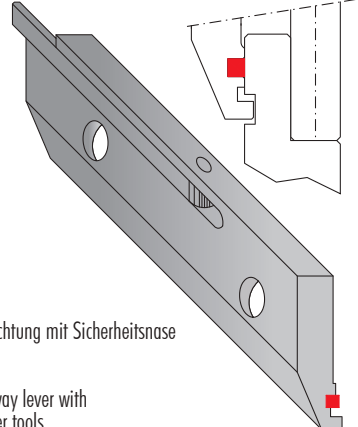
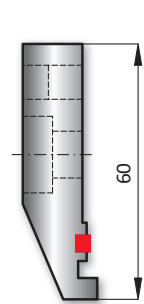

Mechanische Schnellspannvorrichtung mit Sicherheitsnase und Kunststoffandruckleiste
Quick safety clamp plate foldaway lever with polyurethane for sectioned upper tools

Black Line

	L	H	T/mt	Mt
50.666	150	100.00	100	I
50.668	150	120.00	100	I
50.512	150	150.00	100	I

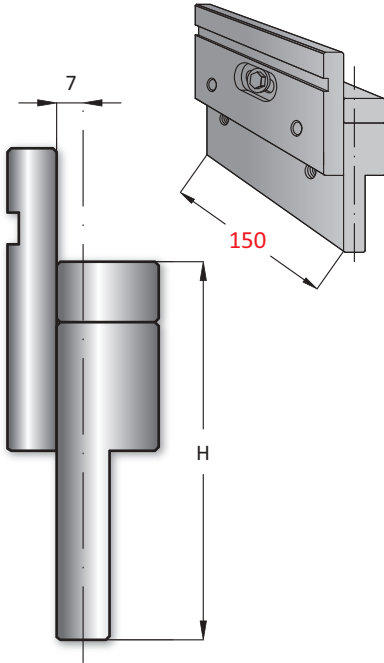

Spannvorrichtung nicht enthalten
Clamp not included

	L	H	T/mt	Mt
50.674	150	120.00	100	I

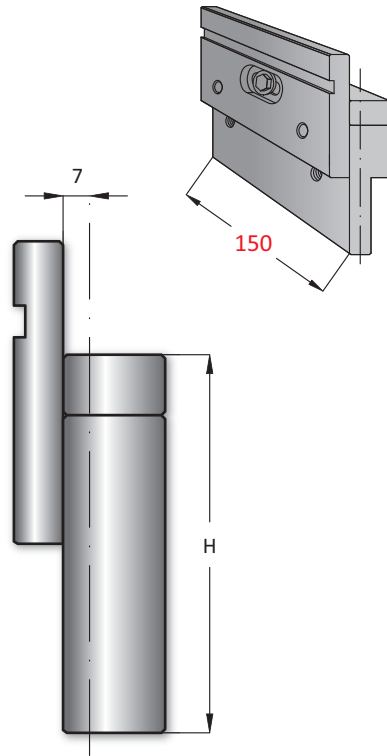

Spannvorrichtung nicht enthalten
Clamp not included

	L	H	T/mt	Mt
50.705	70	100.00	100	I
50.706	70	120.00	100	I
50.708	70	150.00	100	I

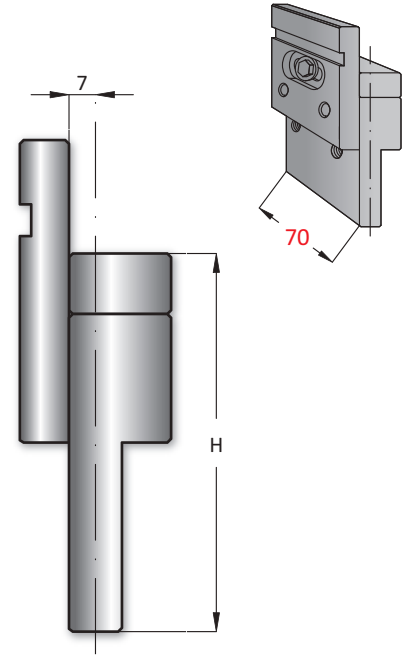

Spannvorrichtung nicht enthalten
Clamp not included

	L	H	T/mt	Mt
50.667	150	120.00	100	I
50.669	150	150.00	100	I

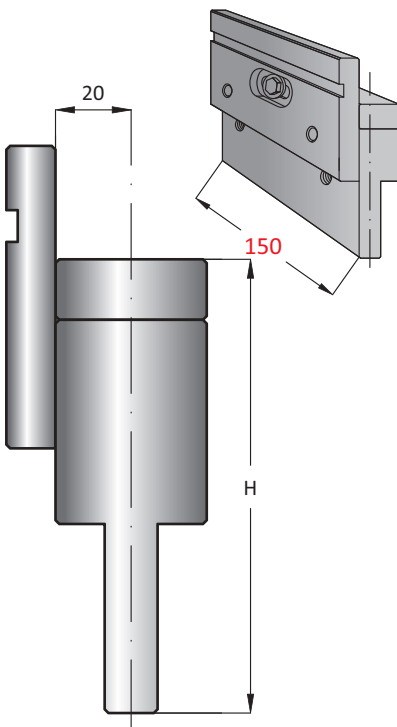

Spannvorrichtung nicht enthalten
Clamp not included

	L	H	T/mt	Mt
50.673	150	120.00	100	I

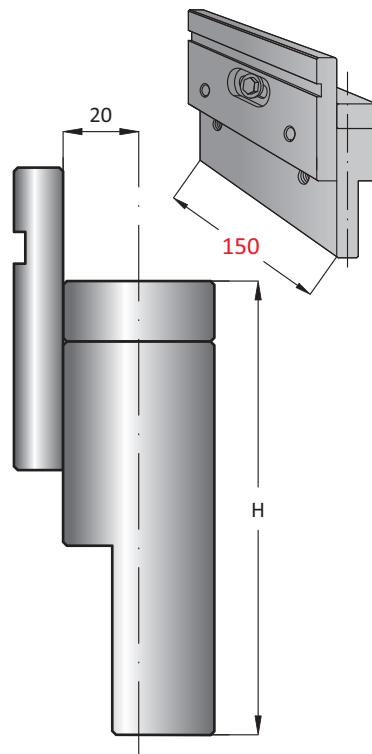

Spannvorrichtung nicht enthalten
Clamp not included

	L	H	T/mt	Mt
50.707	70	120.00	100	I
50.710	70	15.00	100	I

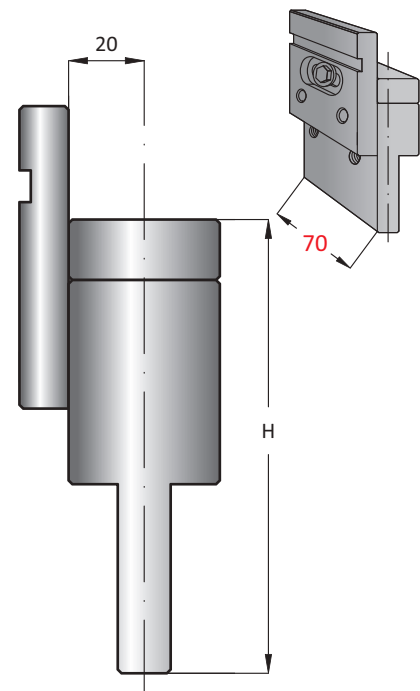

Spannvorrichtung nicht enthalten
Clamp not included

	L	H	T/mt	Mt
60.910	1000	30.00	100	I

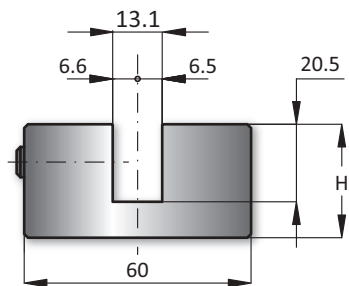
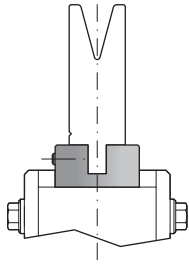

Beyeler-Trumpf Adapter

	L	H	T/mt	Mt
60.919	835	55.00	100	I

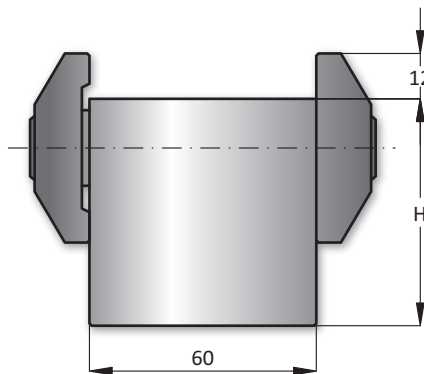
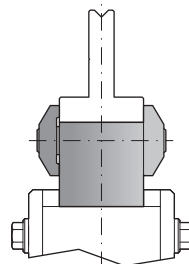

Amada Adapter

	L	H	T/mt	Mt
60.920	1000	60.00	100	I

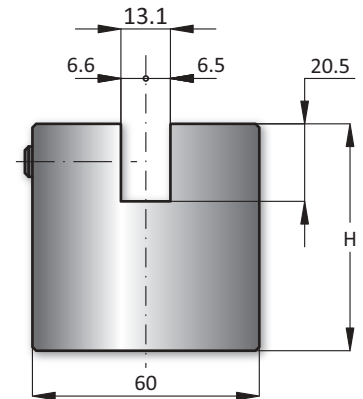
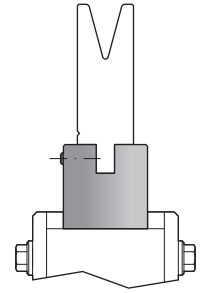

Amada-Beyeler/Trumpf Adapter

	L	H	T/mt	Mt
60.925	835	40.00	100	I

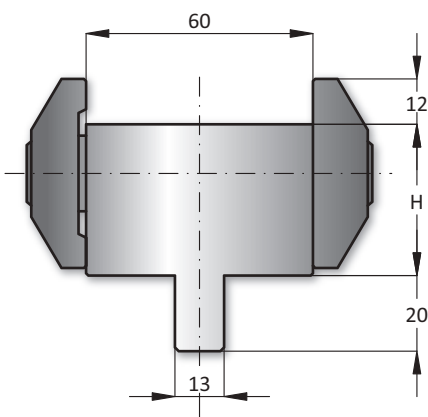
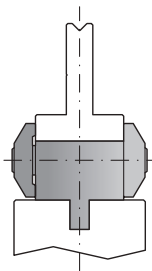

Beyeler/Trumpf Adapter

	L	H	T/mt	Mt
60.930	835	40.00	100	I

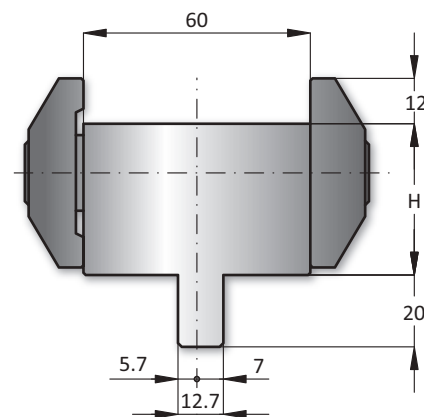
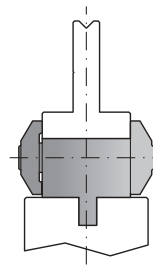

LVD-Amada Adapter

	L	H	T/mt	Mt
60.935	1000	30.00	100	I

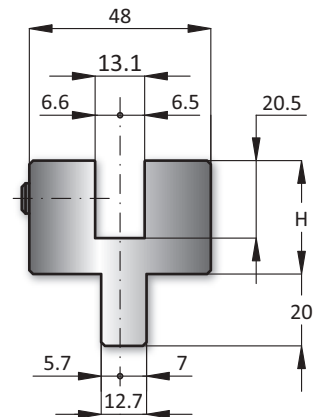
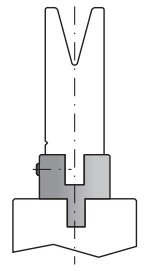

LVD-Beyeler/Trumpf Adapter

Black Line

	L	H	T/mt	Mt
60.940	500	40.00	100	I

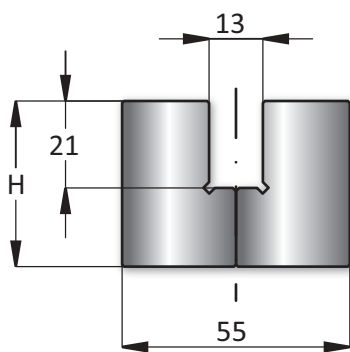
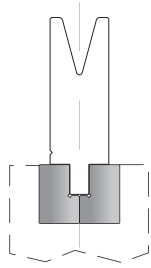

Wila-EHT Adapter

	L	H	T/mt	Mt
60.945	835	60.00	100	I

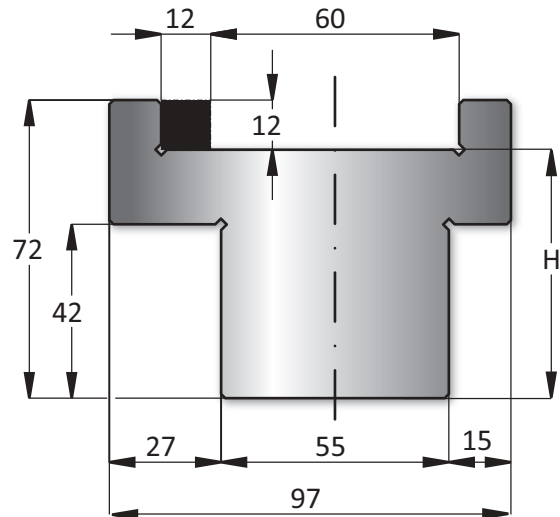
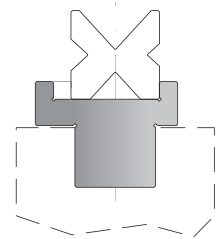

Amada-EHT Adapter

	L	H	T/mt	Mt
60.950	500	45.00	100	I

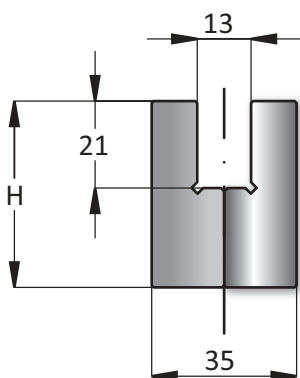
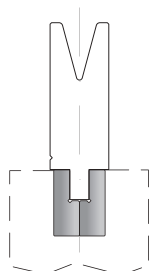

Wila-Weinbrenner Adapter

	L	H	T/mt	Mt
60.955	835	65.00	100	I

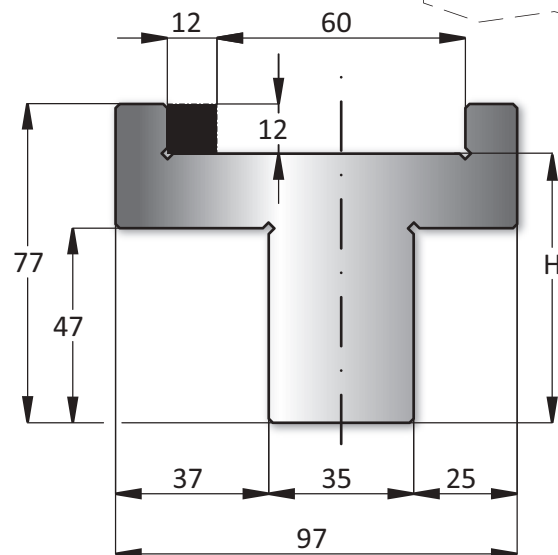
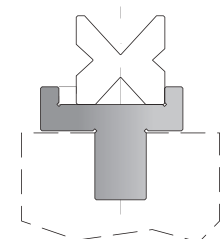

Amada-Weinbrenner Adapter

	α	H	T/mt	Mt
20.720	80°	170.00	200	I

100 mm

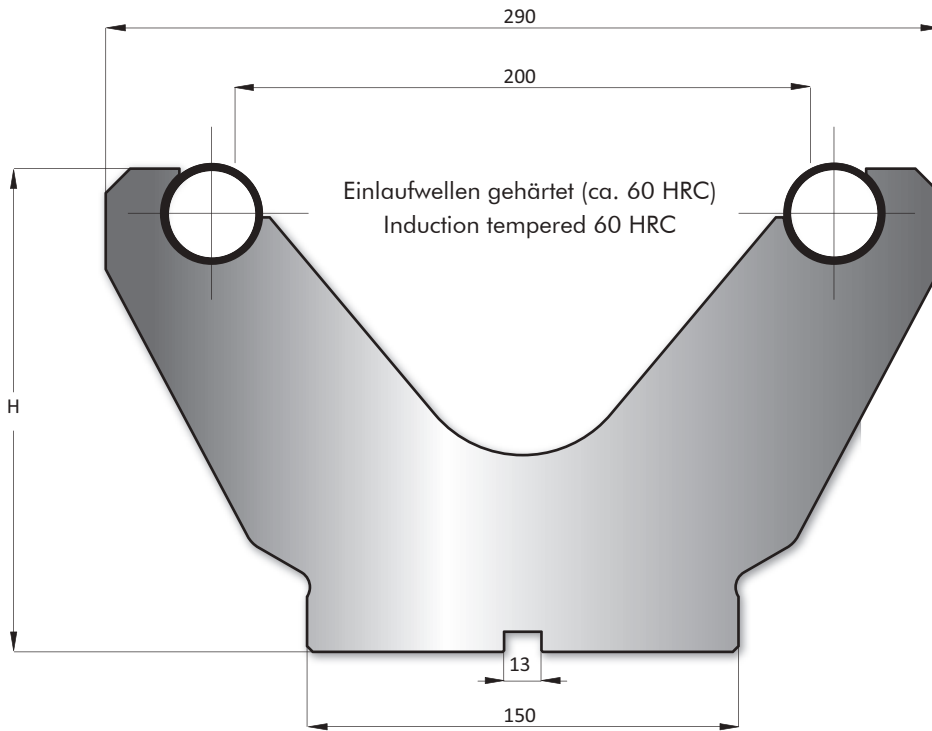

80°

	α	H	T/mt	Mt
20.725	80°	200.00	200	I

100 mm

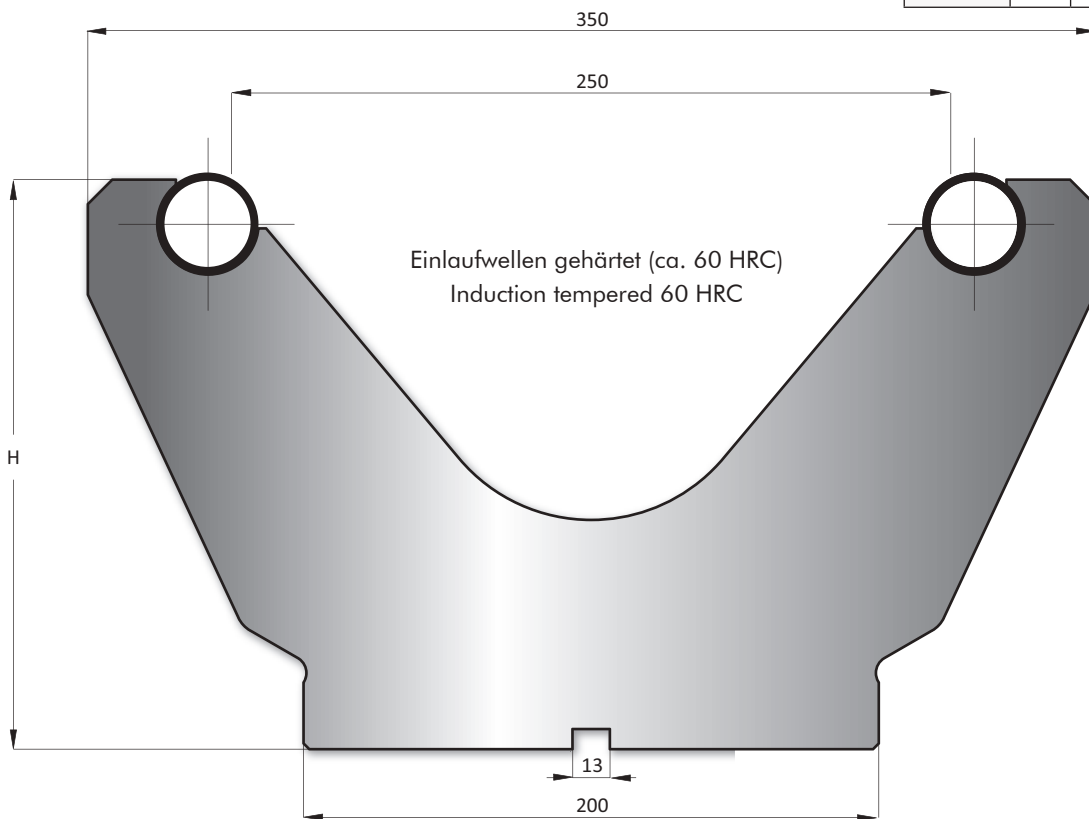

80°

Black Line

100 mm

	α	H	T/mt	Mt
20.732	80°	250.00	200	I

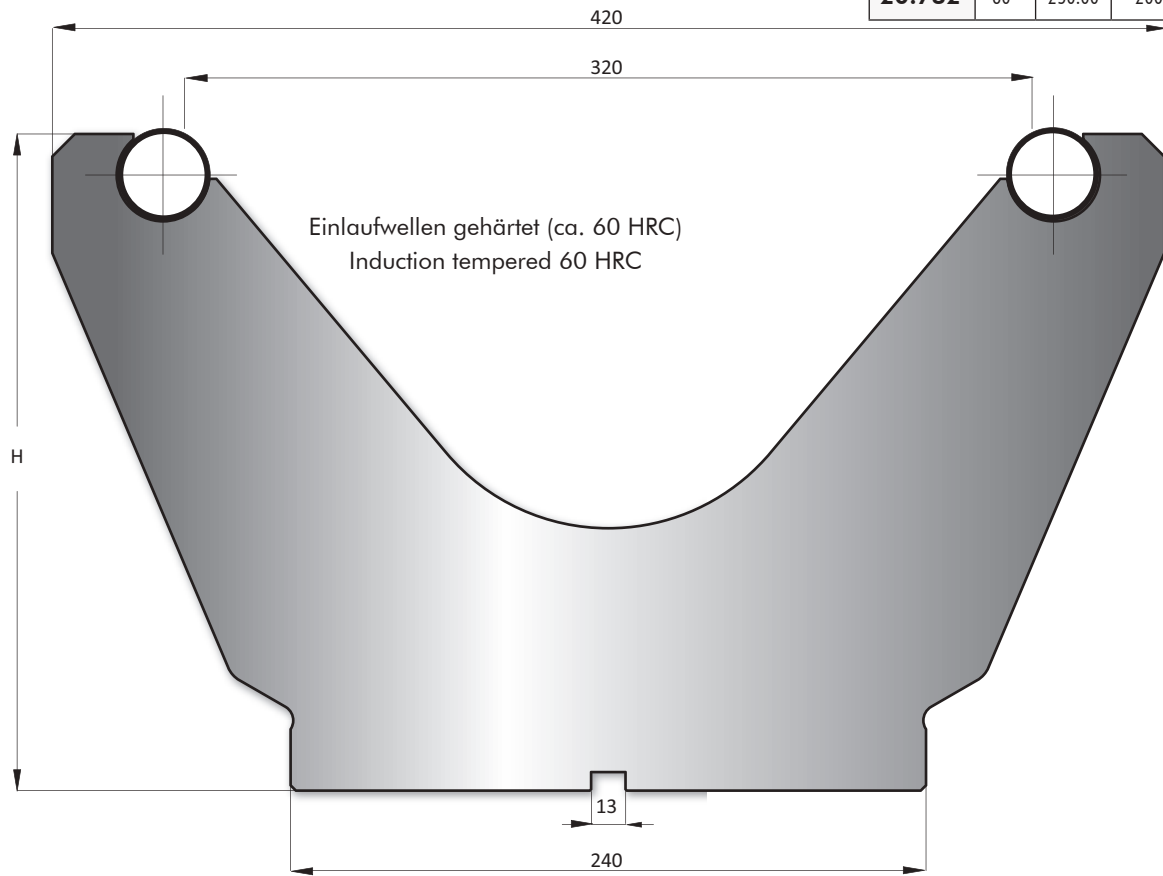

80°

100 mm

20.701

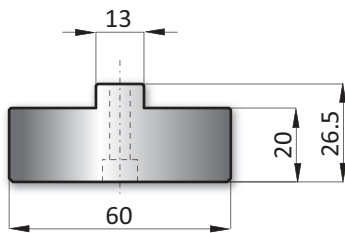

Amada

100 mm

20.703

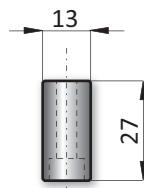

Beyeler / Trumpf

100 mm

20.705

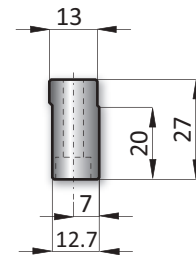

LVD

100 mm

20.707

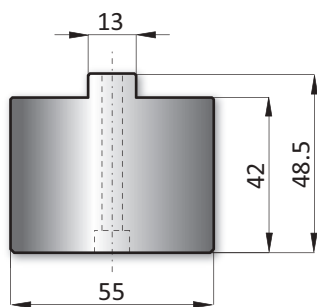

EHT

100 mm

20.709

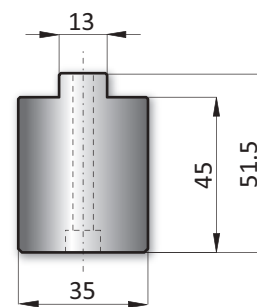

Weinbrenner

Schwenkbiegewerkzeug

Special Foldingtools

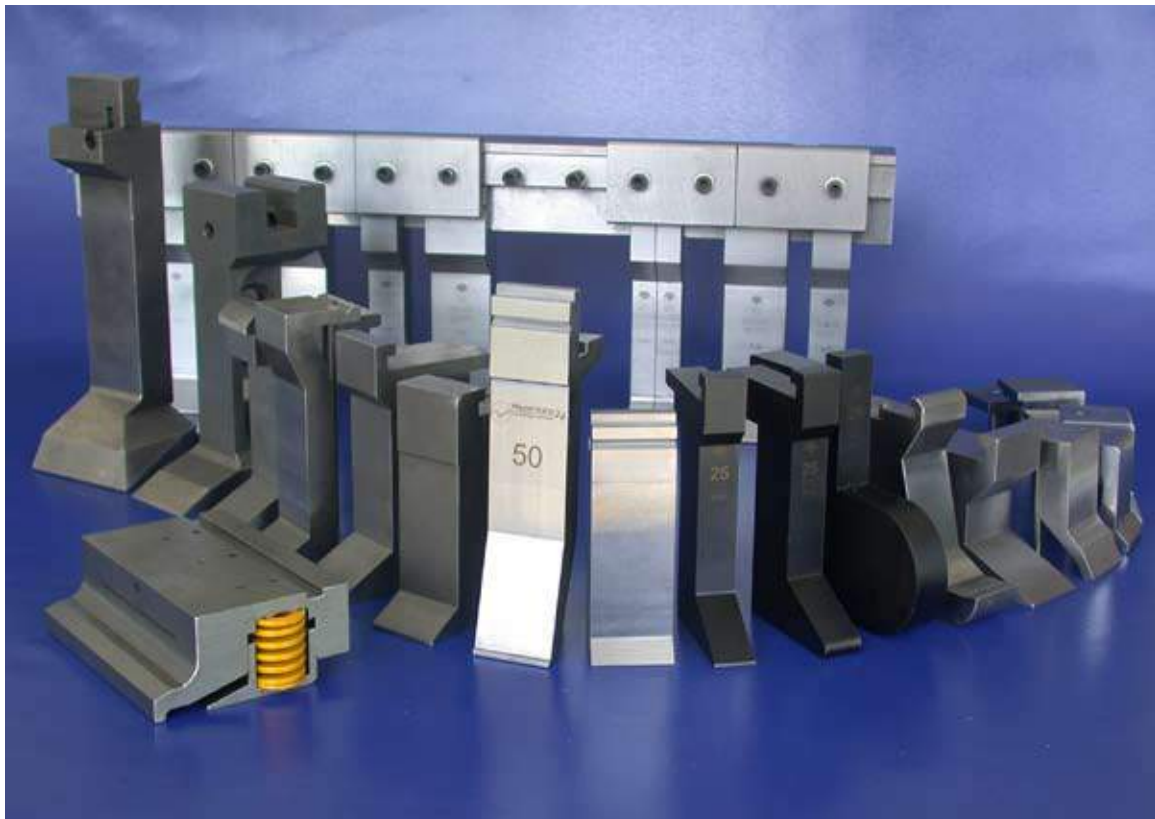

Oberwerkzeuge für Ihre Schwenkbiegemaschine... / Upper tools for your folding machine...

Westermann24 liefert Ihnen Schwenkbiegewerkzeuge für Ihre Maschine. Sie bekommen von uns Werkzeuge in geschliffener und geschliffener Ausführung. Entsprechend der gewünschten Verschleißfestigkeit bietet Westermann24 verschiedene Qualitäten in vergüteter oder gehärteter Ausführung an.

Westermann24 delivers special folding tools for your machine. You will get paint coated and grinded tools. According the order wearing stability Westermann24 offers different quality levels determined orhardened.



... oder Standardwerkzeuge. /
... or conventional tools.



Maschinenansläge bis 6500mm /
keystrokes tills 6500 mm



Adapterschiene für geteilte Werkzeuge /
adaptor rail for divides tools

Schwenkbiegewerkzeug

direkt einsetzbar auf Schwenkbiegemaschinen von:

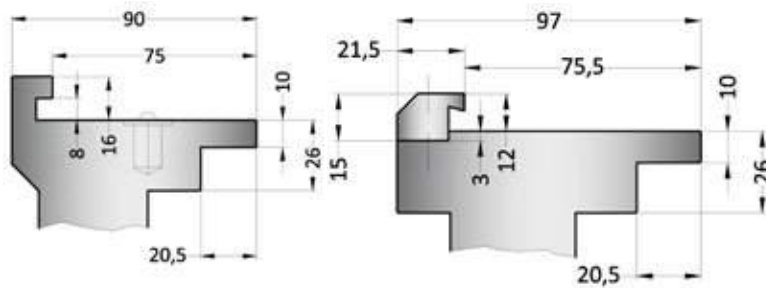

Fasti

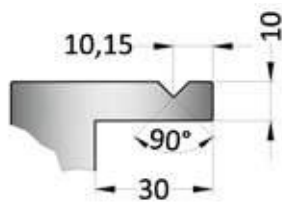

Schröder

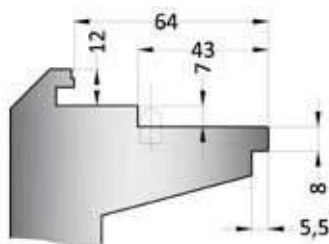

RAS

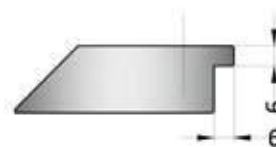
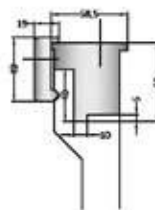
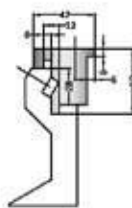

Lotze

Special Foldingtools

directly able to work on folding machines of:

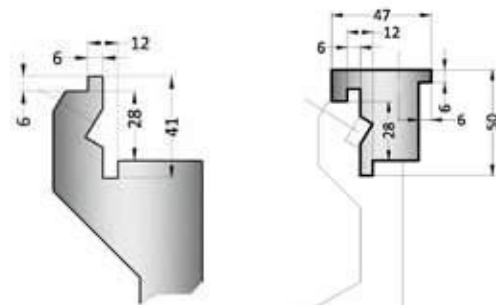
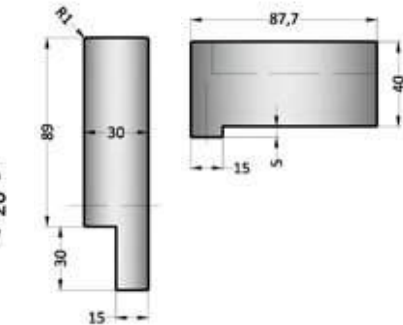

RAS

modifiziert für Ihre Maschine / modified for your machine

Material:

Westermann24 nutzt die vielfältigen Möglichkeiten der Werkstoffkunde, um Ihnen bestmögliche Qualität zu garantieren.

Verwendeter Werkstoff ist:

- 1.2312, vergütet auf 1000-1200N/mm²

Ausführung wahlweise:

gefräst, geschliffen oder zusätzlich gehärtet

material:

Westermann24 uses the many possibilities of the material engineering, to guarantee best quality.

used materials are:

- 1.2312, tempered to 1000-1200N/mm²

Design optional:

Milled, grinded or additional hardened

4.01.001

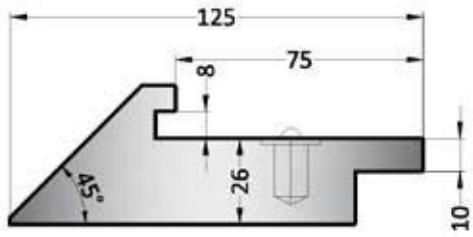

45°

4.01.002

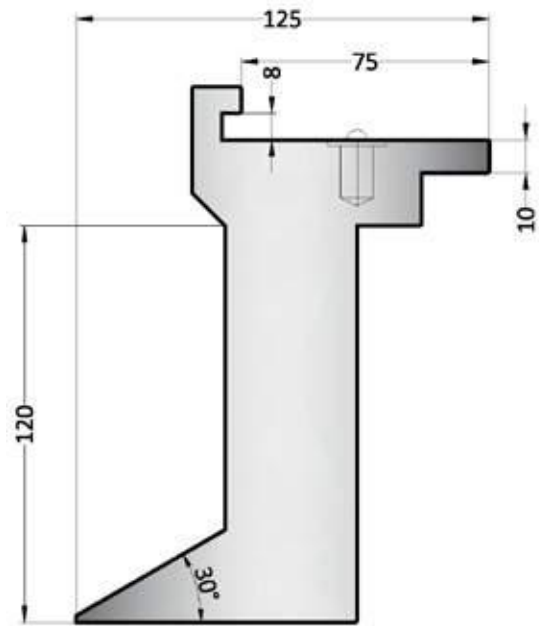

30°

4.01.003

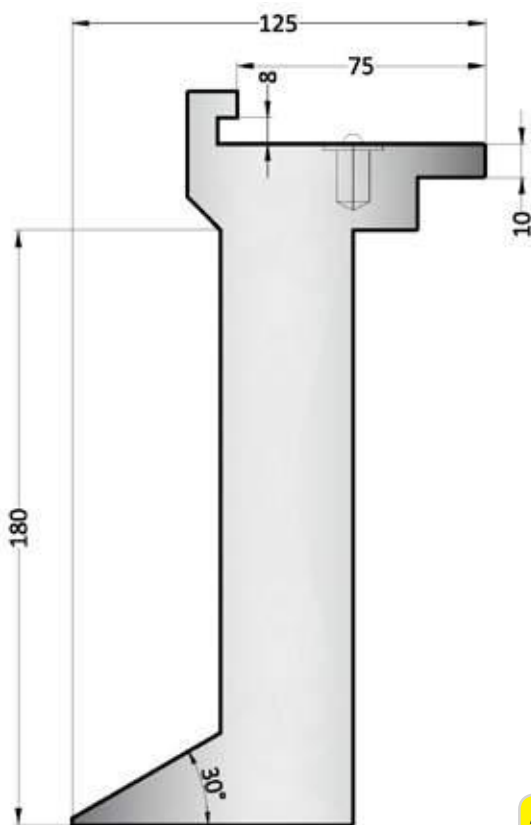

30°

4.01.004

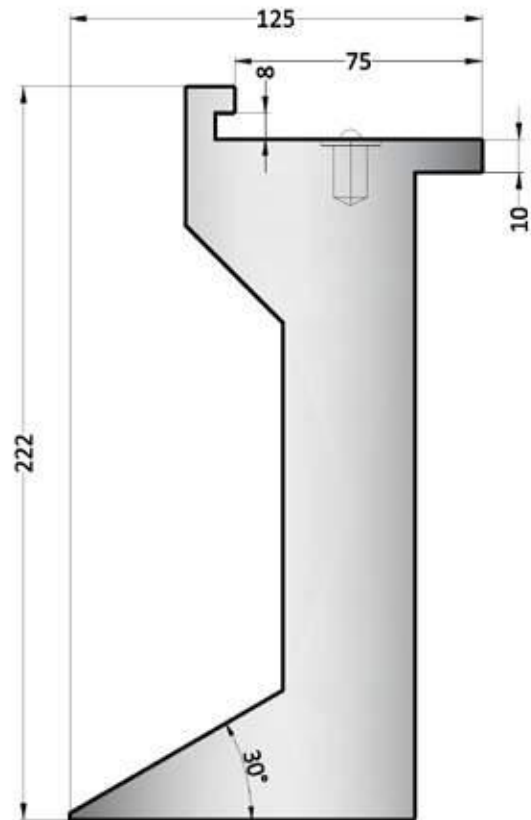

30°

4.01.005

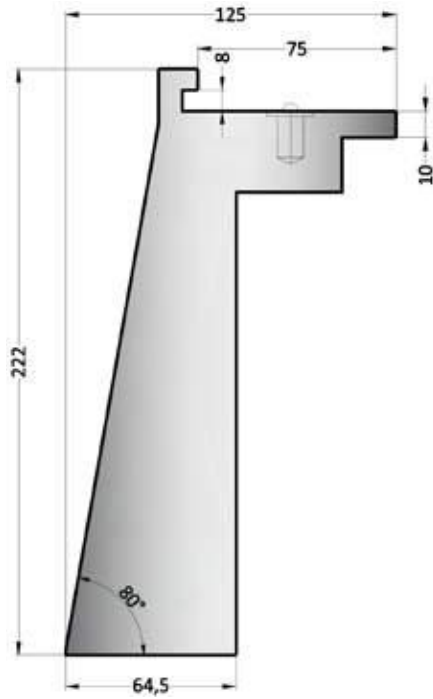

80°

4.01.006

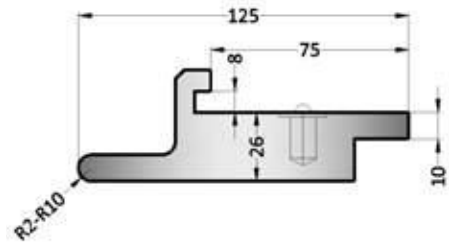

45°

4.02.001

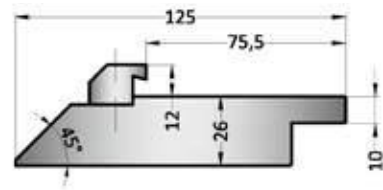

45°

4.01.007

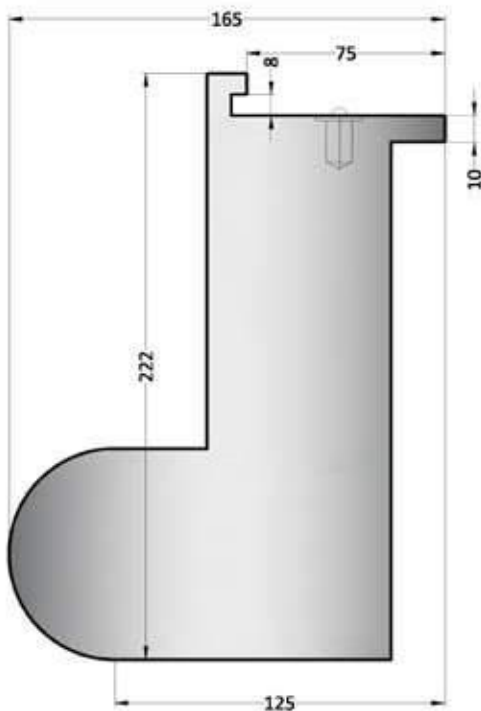

4.02.002

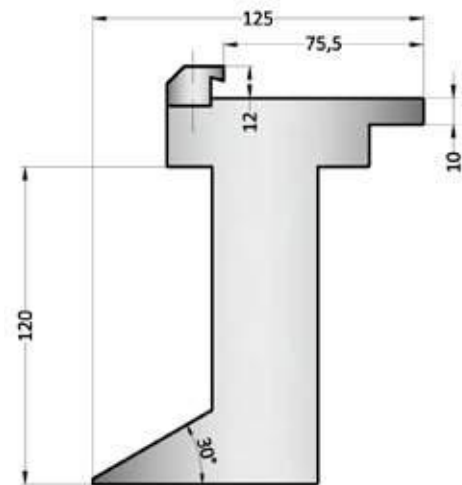

30°

4.02.003

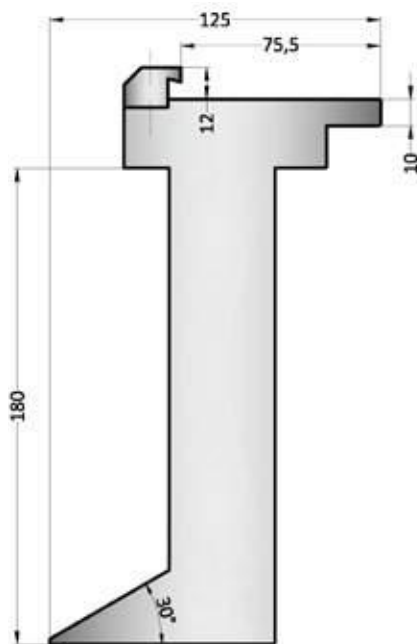

30°

4.02.004

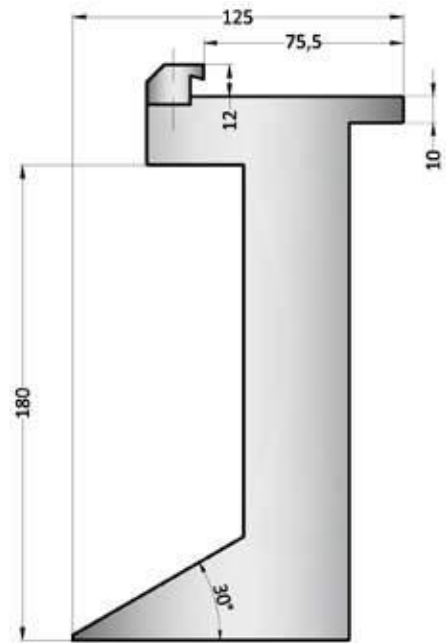

30°

4.02.005

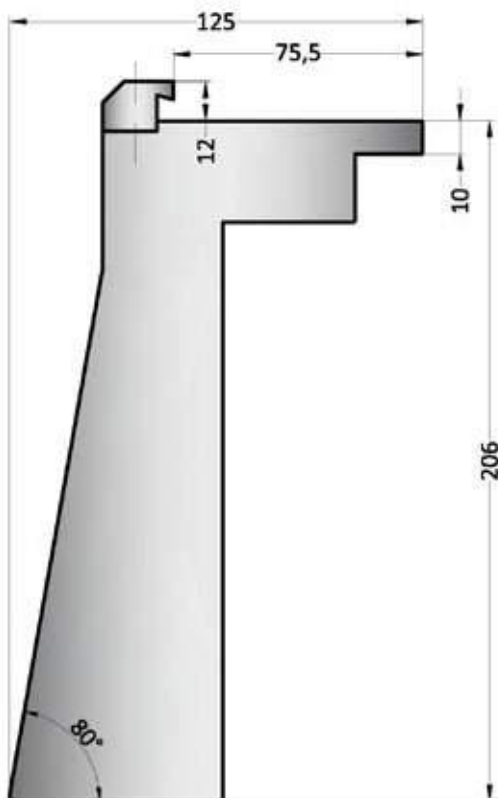

80°

Black Line

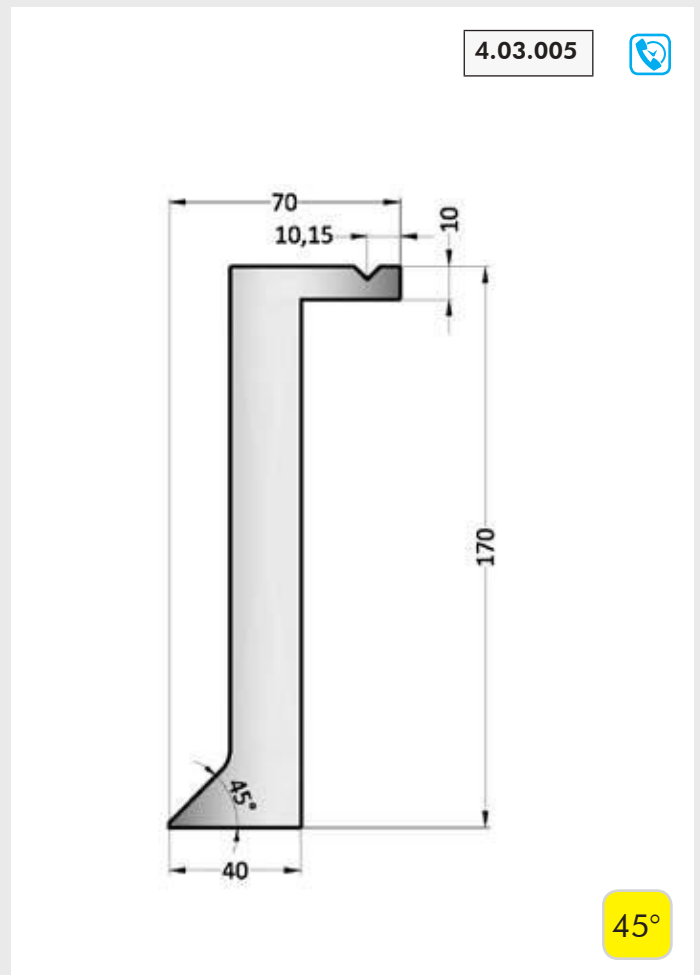
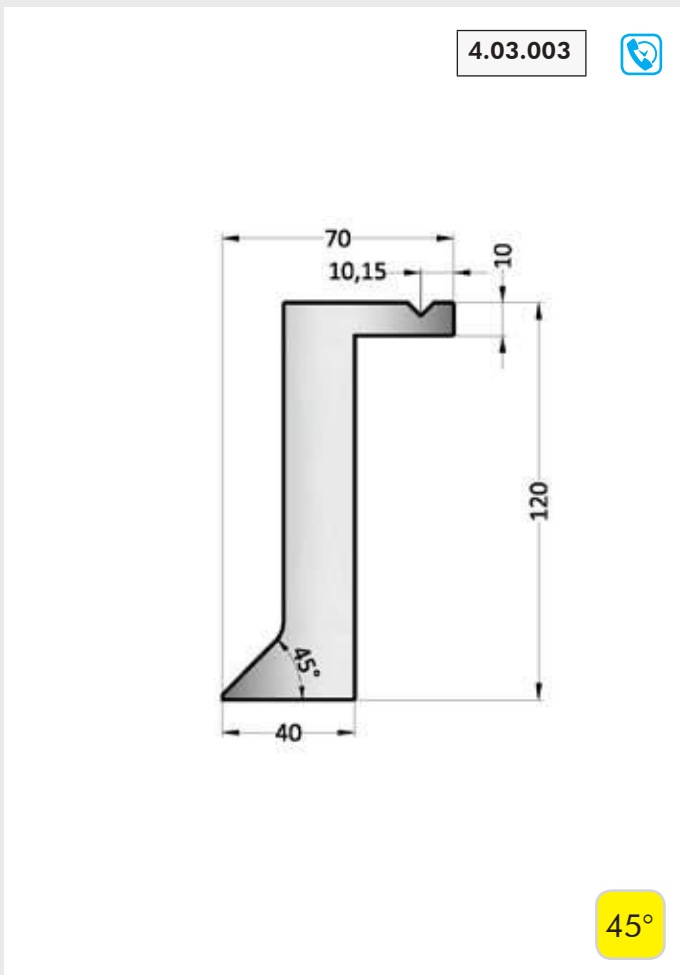
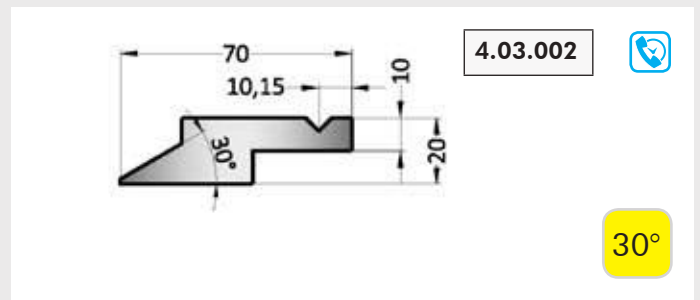
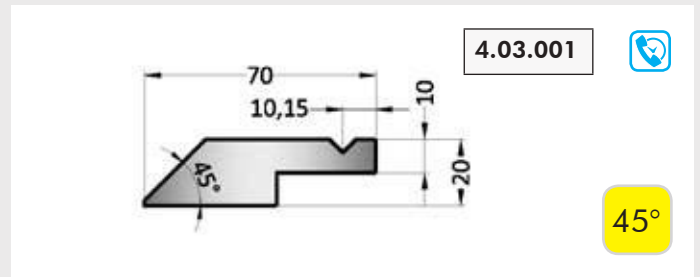
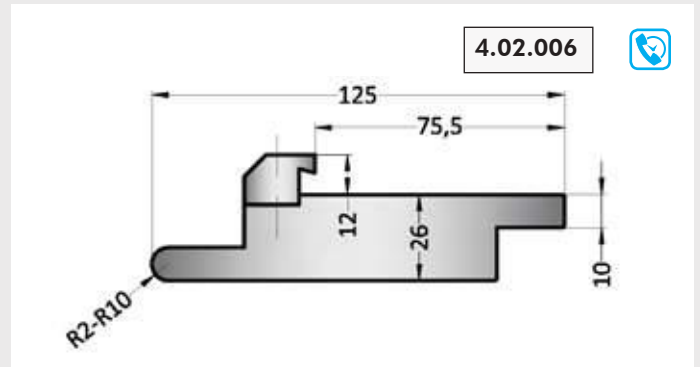
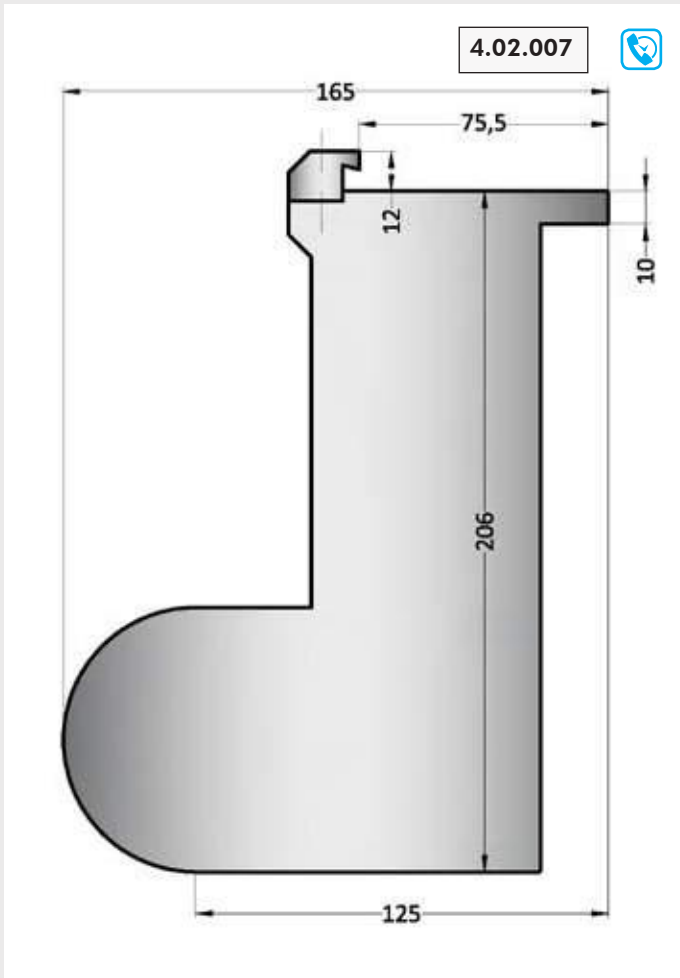

Black Line

4.03.006

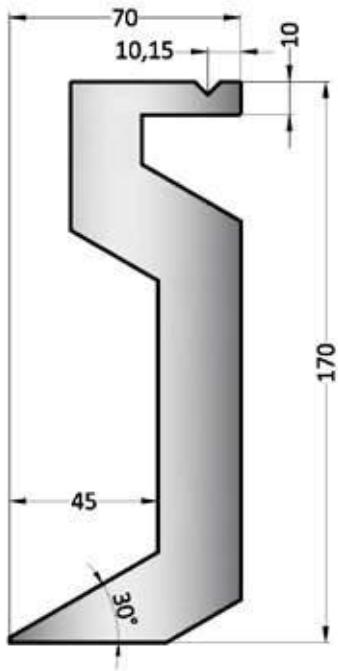

30°

4.03.007

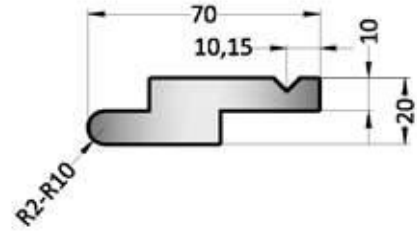

4.04.001

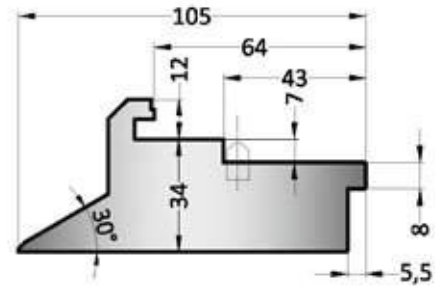

30°

4.03.008

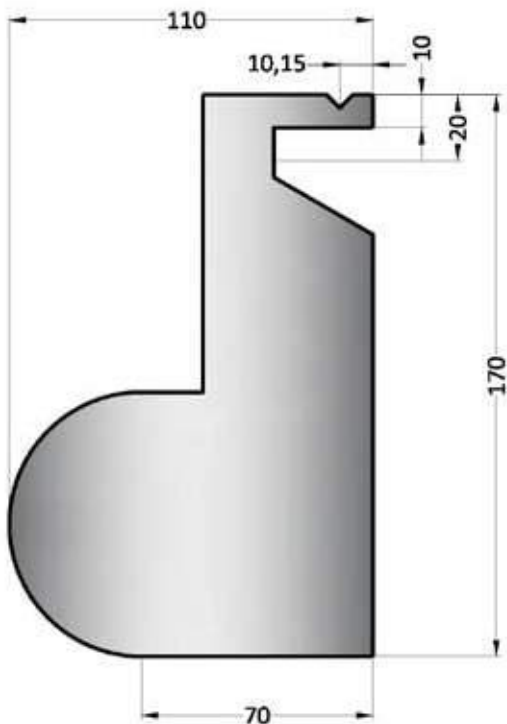

4.04.002

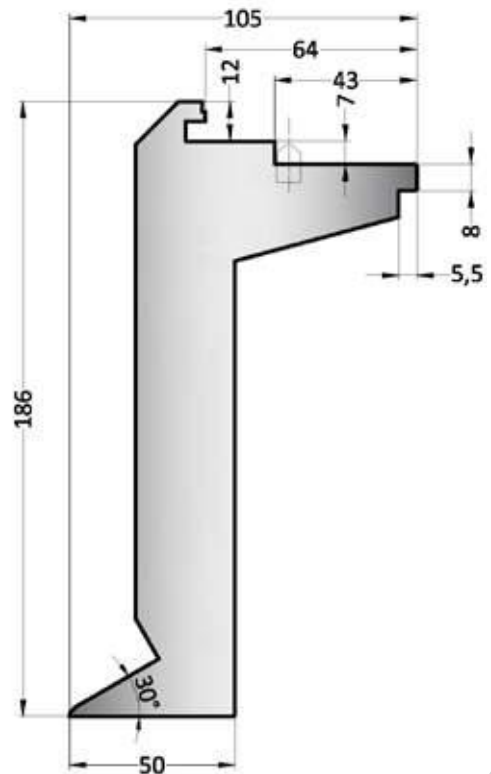

30°

4.04.003

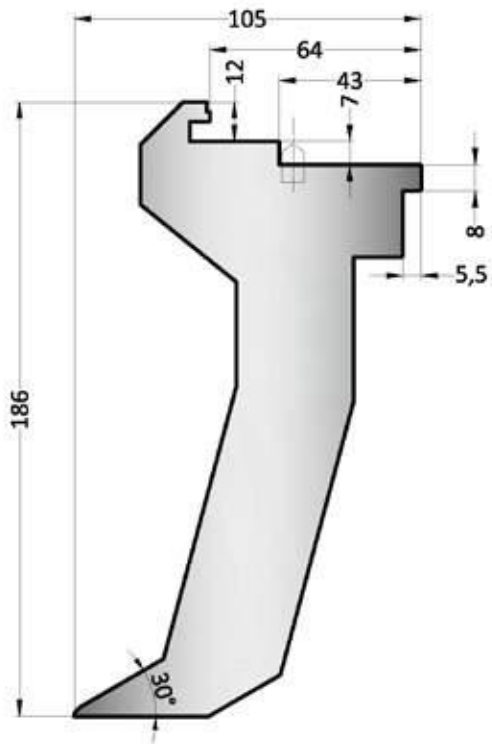

30°

4.04.004

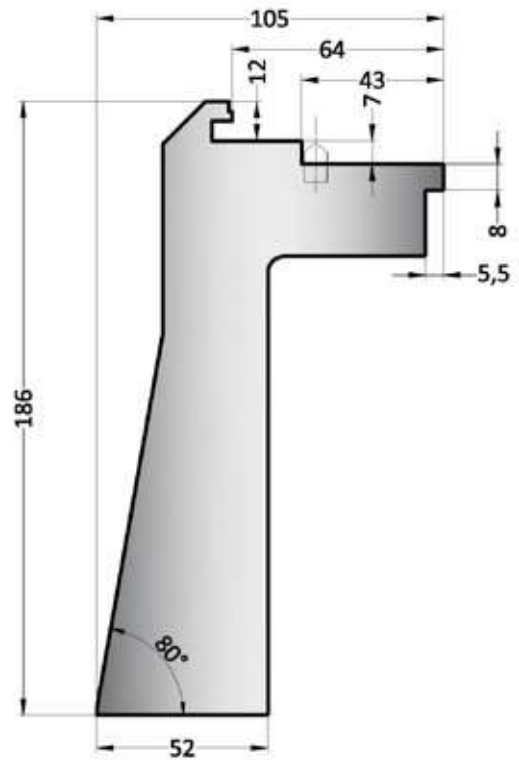

80°

4.04.005

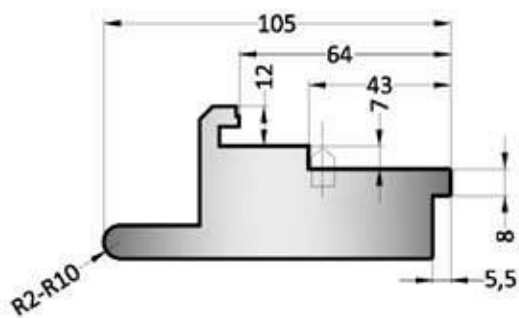

4.04.006

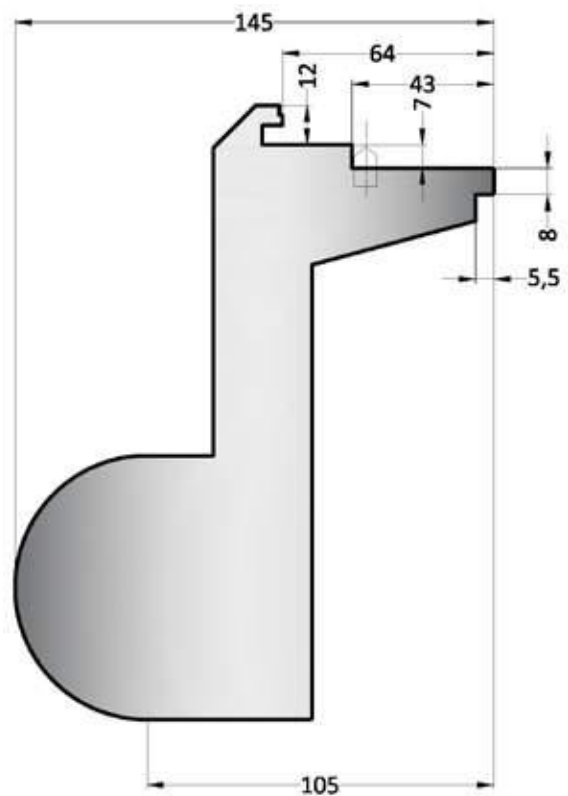

4.05.001

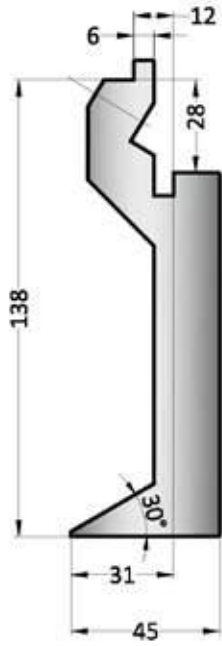

30°

4.05.002

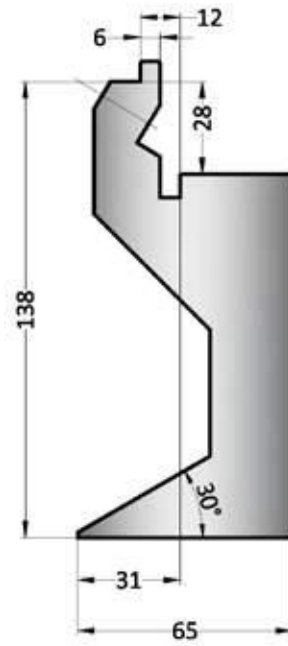

30°

4.05.003

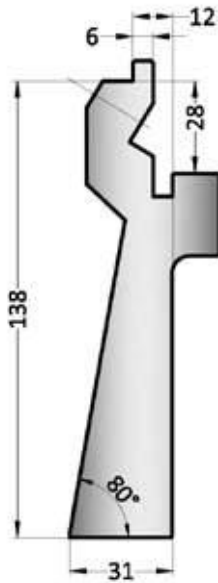

80°

4.05.004

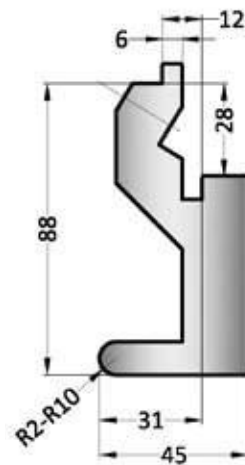

4.05.005

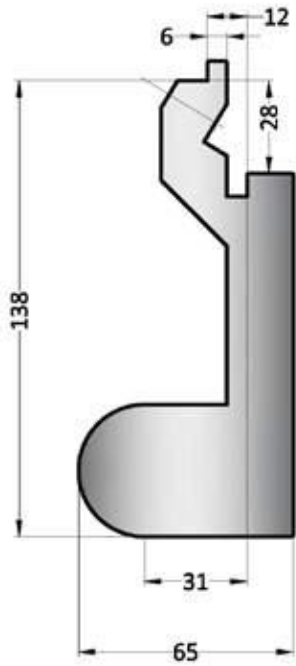

4.06.001

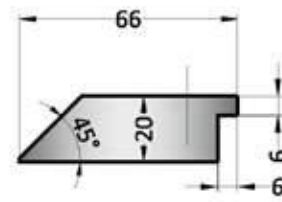

45°

4.07.001

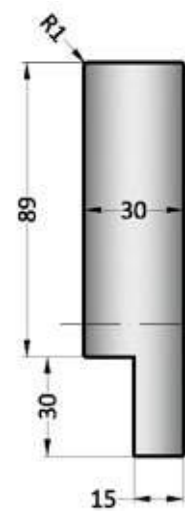

4.06.002

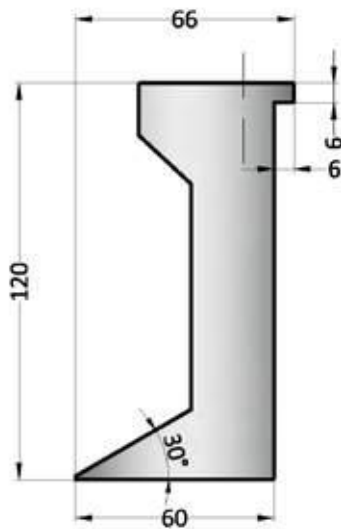

30°

4.07.002

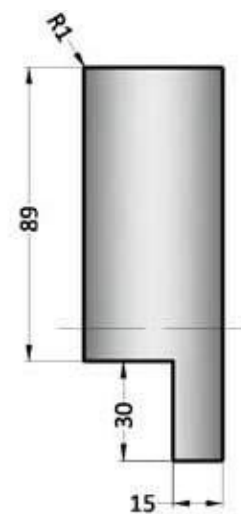

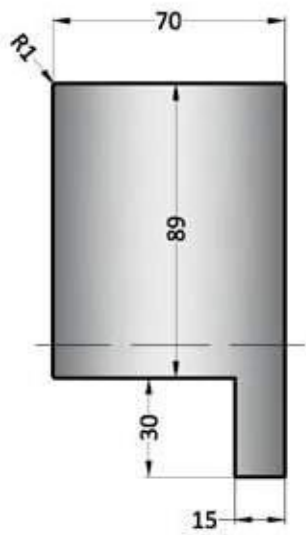

4.07.003

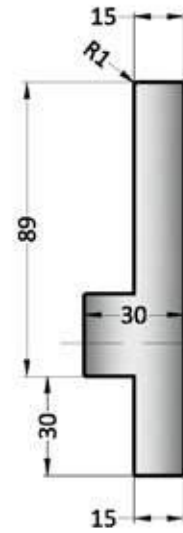

4.07.004

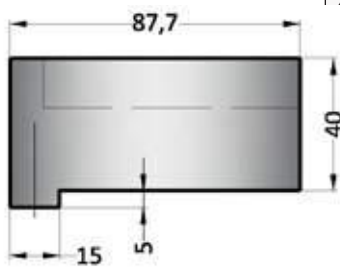

4.08.001

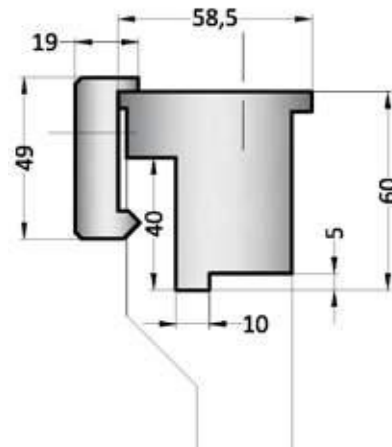

5.01.002

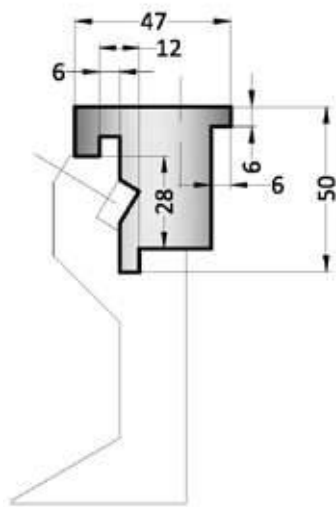

5.01.001

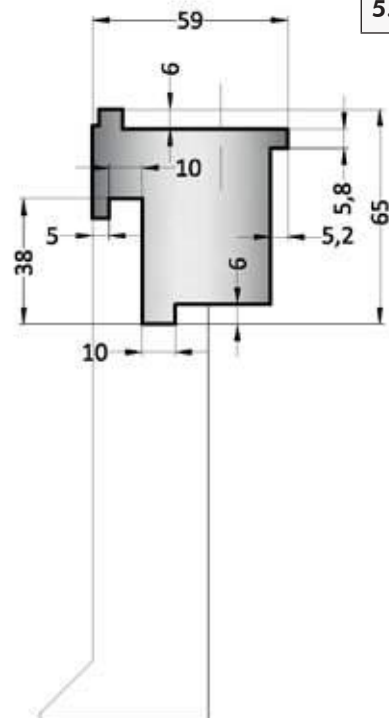

5.01.003



Black Line

Blockmatrizen

Block dies

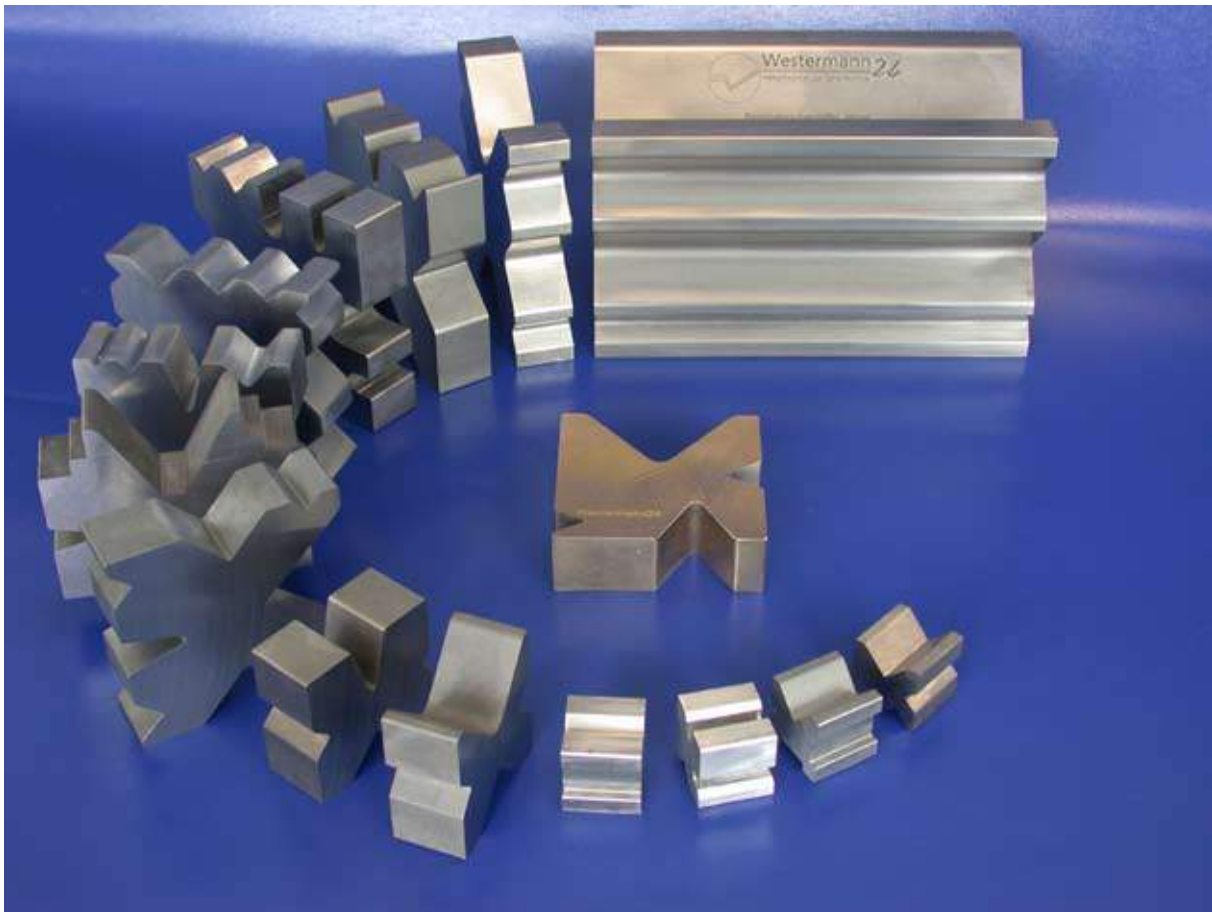

Blockmatrizen in verschiedenen Ausführungen: gefräst, geschliffen, gehärtet. / Block dies in different designs: milled, grinded, hardened.

Vorteile:

- die einteilige Blockmatrize lässt sich durch stirnseitiges Anheben schnell drehen.
- Durch das Verschieben gegen den Anschlag, kann der Wechsel zu einer anderen V-Öffnung schnell vorgenommen werden.
- die einteilige Matrize hat keinen Stoß.
- die Anschaffungskosten im Vergleich zu 1- V- Matrizen sind meistens günstiger.

Advantages:

- with frontal lifting its possible to turn the one part block dies quickly.
- the change to a other V- opening is possible very quickly.
- the one-part dies has no impact barrier.
- the cost of purchase in amparrison to 1- V- dies are more favourable.

2.05.009

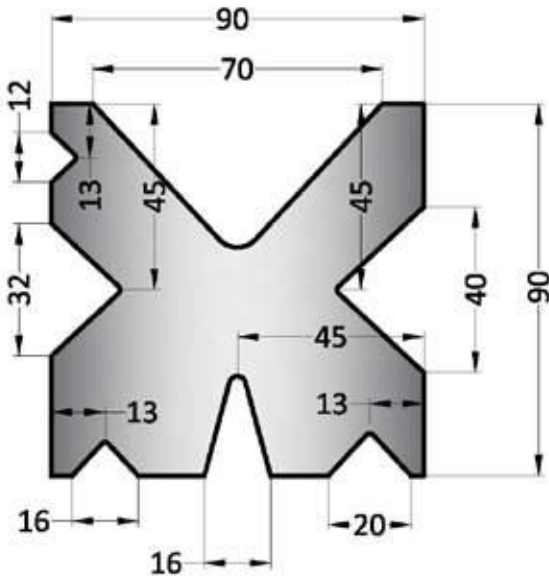

Nicht bemaßte Winkel = 30° / 86°

2.05.010

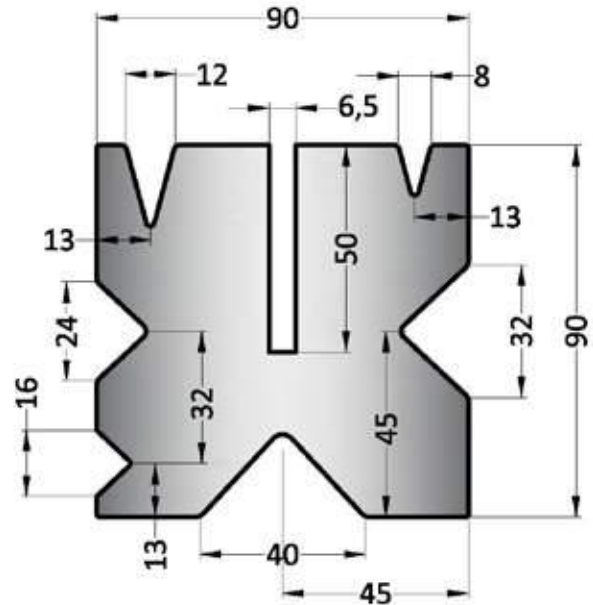

Nicht bemaßte Winkel = 30° / 86°

2.06.010

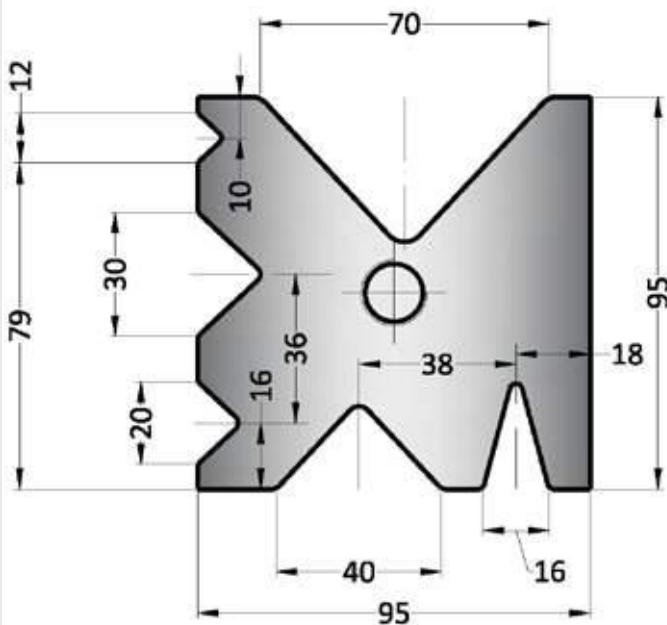

Nicht bemaßte Winkel = 30° / 86°

2.07.010

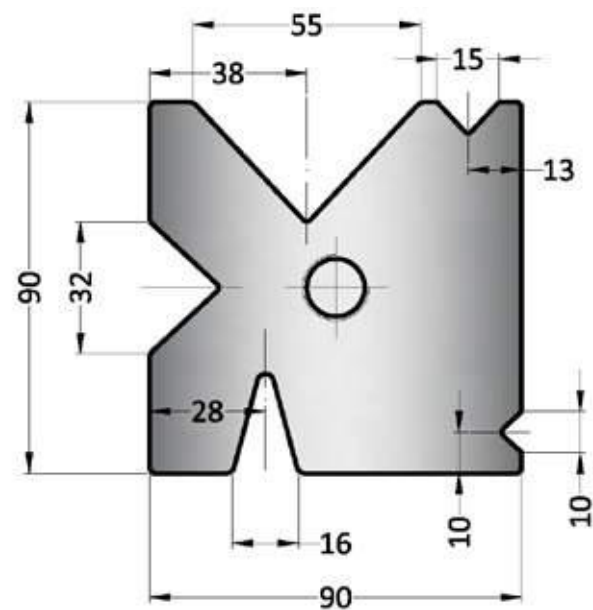

Nicht bemaßte Winkel = 30° / 86°

2.09.190

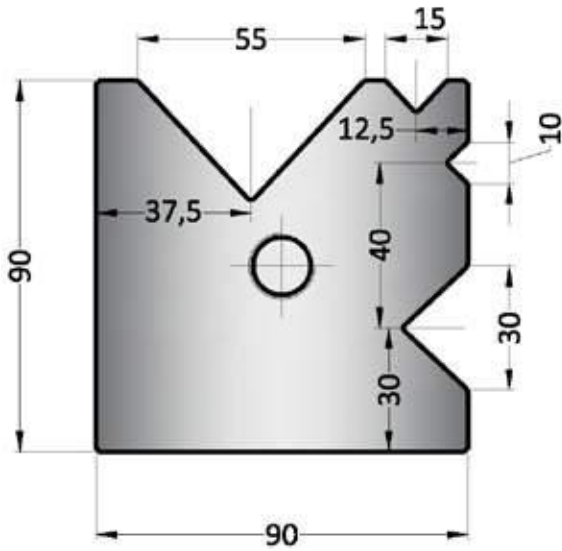

Nicht bemaßte Winkel = 86°

2.09.210

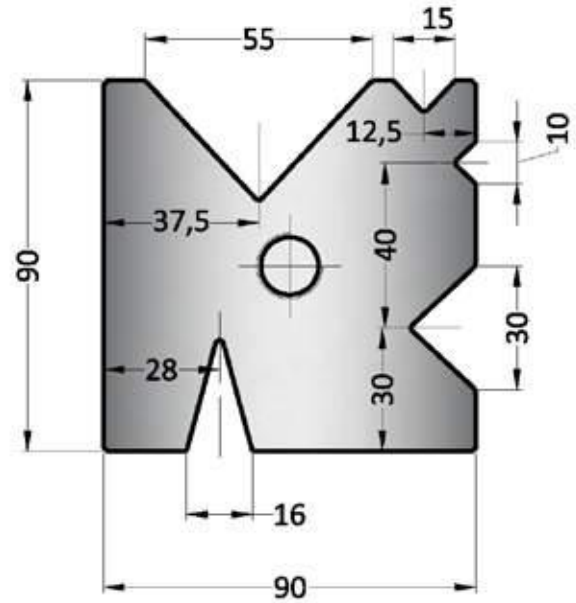

Nicht bemaßte Winkel = $30^\circ / 86^\circ$

2.14.309

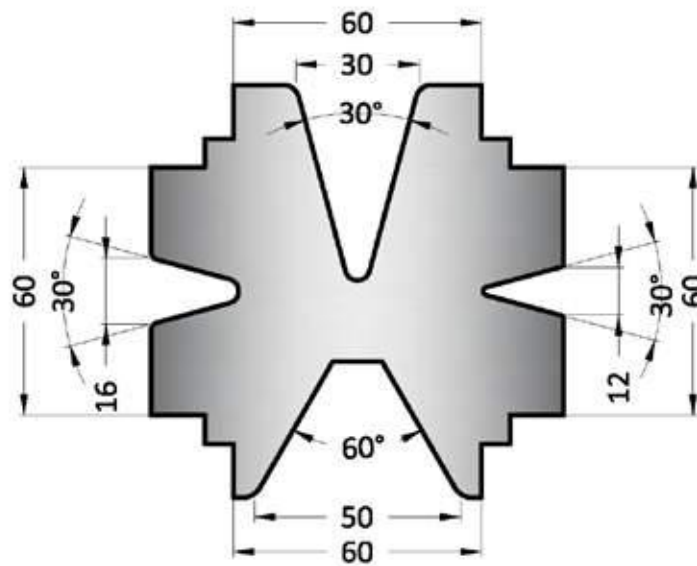

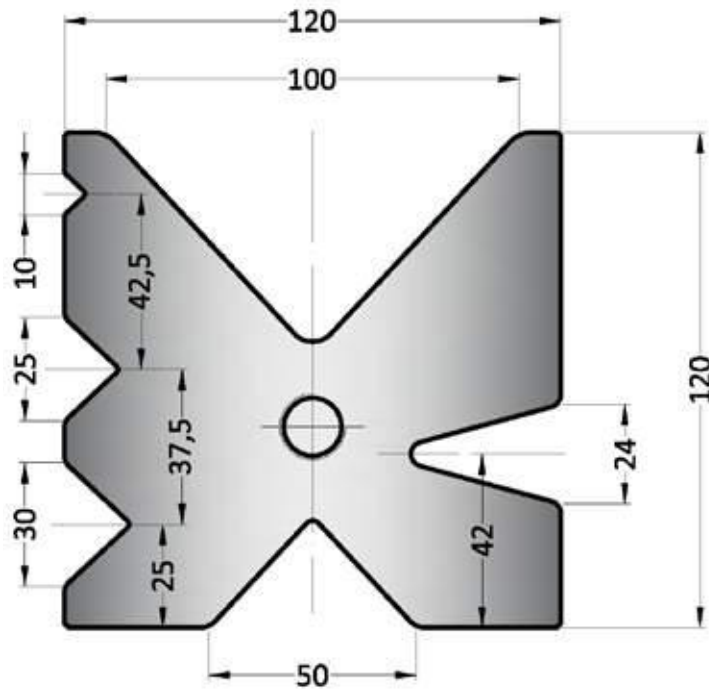

2.18.010



Nicht bemaßte Winkel = 30° / 86°

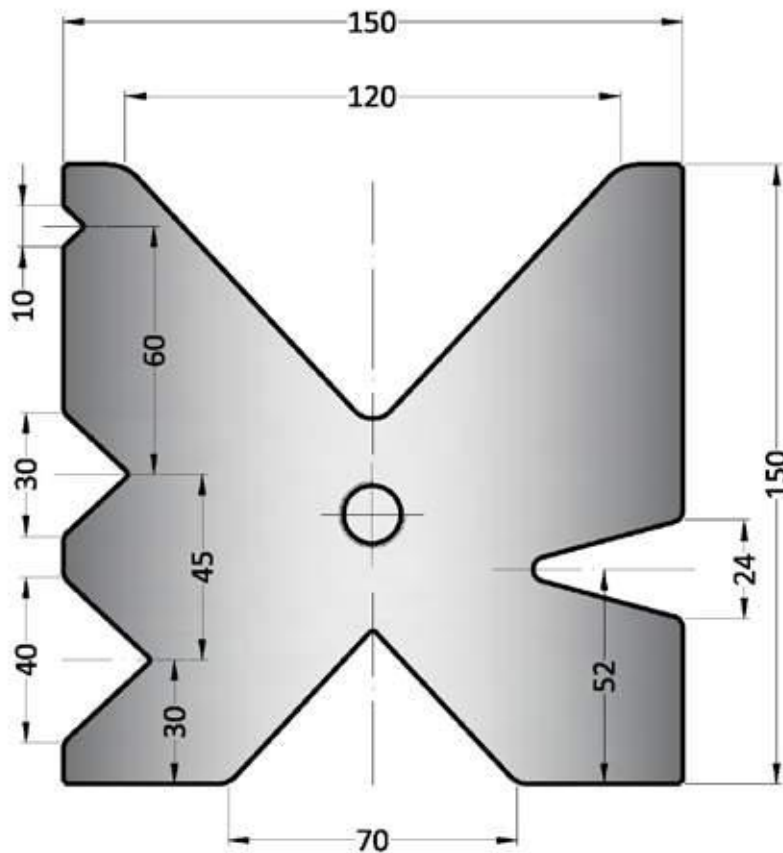

2.18.011



Nicht bemaßte Winkel = 30° / 86°

Black Line

Verstellbare Öffnungsweite

Modell B = V24-124(125t/m)
Modell D = V60-V180(200t/m)
Modell E = V120-300(400t/m)



Kleine Öffnungsweite / small opening width

Adjustable opening width

Model B = V24-124(125t/m)
Model D = V60-V180(200t/m)
Model E = V120-300(400t/m)



Große Öffnungsweite: z.B. bis 300 mm / large opening width: for example till 300mm

Vorteile:

- Die Matrize deckt einen sehr breiten Gesenkbereich ab. Ständiger Matrizenwechsel ist daher nicht notwendig.
- Abdruckarmes Biegen mittels sich mitdrehender Laufrollen.
- Minimaler Verschleiß, durch gehärteten Laufrollen die sich mitdrehen.
- Weniger Presskraft im Vergleich zu konventionellen Matrizen erforderlich.
- Herstellung unterschiedlicher Biegeradien am Produkt durch Verstellen der Gesenkbreiten.
- Verringerung der Stillstandszeiten um bis zu 30% durch schnelles und einfaches Austauschen der Einstellleisten.
- Minimale Wartungskosten:
- Die Laufrollen können getauscht werden, ein Nacharbeiten der kompletten Matrize ist nicht notwendig.
- Austauschbare Kunststoffstreifen schützen die Matrizeileile gegen Verunreinigungen durch Zunder oder andere Verschmutzungen.
- Die VLM-Matrize bietet eine äußerst geringe Störkontur im Vergleich zu herkömmlichen verstellbaren Matrizen.

Advantages:

- The die covers a very wide swage sizes range therefore a permanent change of the dies is not necessary.
- Low impressed welding with rotating support rolls.
- Minimal wear because of hardened support rolls with rotating too.
- Fewer press force in comparison to conventionally dies necessary.
- Producing of different bending radii at the product because of recalibration of the swage size.
- Reducing the down times till to 30% because of a quick and easy change from the profiles of setting.
- Minimal maintenance costs:
- The support rolls can be changed, a rework activity of the complete die is not necessary.
- Changeable plastic strips protect the parts of the die against contamination.
- The VLM-die offers extremely low culture of malfunction in comparison to conventional adjustable dies.

	α	V	T/mt
65.125	max. 30°	25-125mm	125
empf. Materialstärke 3-15mm			

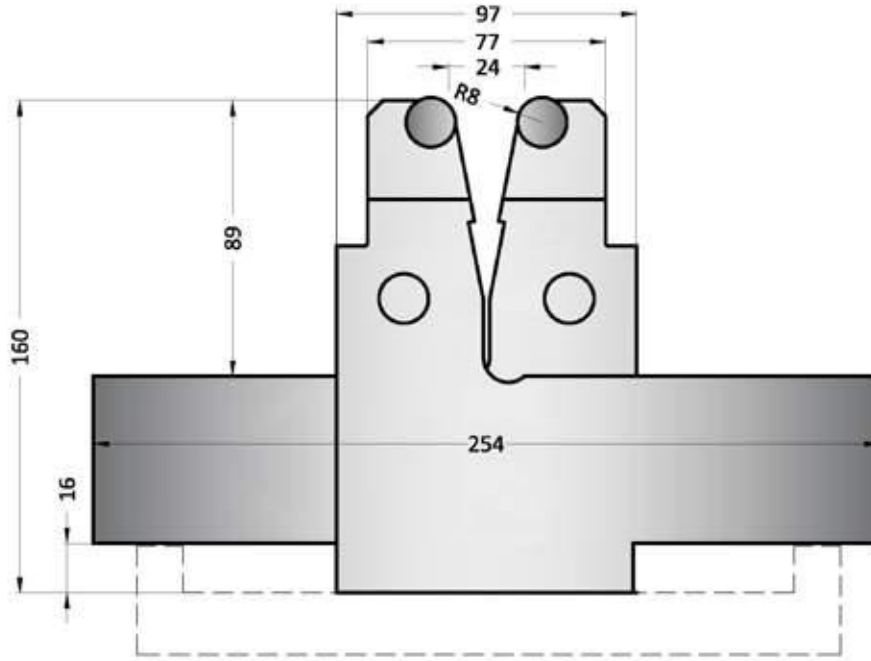

- 250 mm
- 500 mm
- 550 mm
- 1000 mm
- 1050 mm

geschlossen /
closed

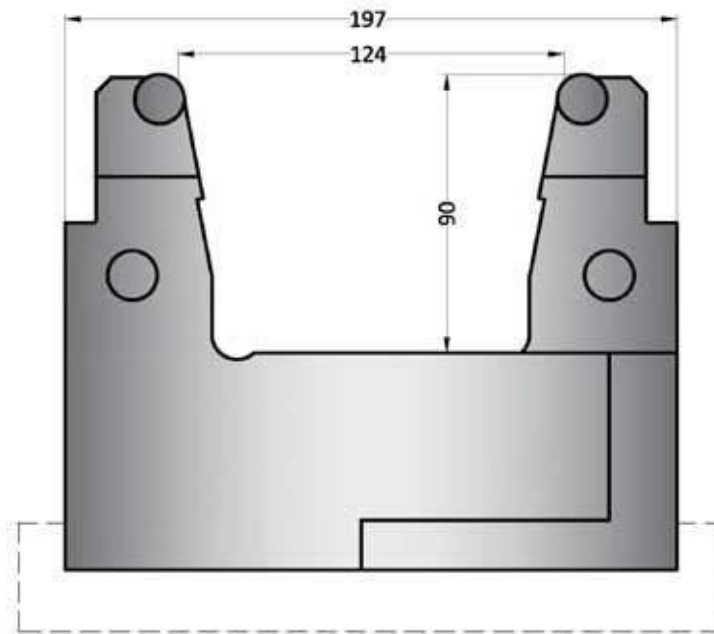

offen /
open

66.125 H=20

500 mm

1000 mm

2000 mm

3000 mm

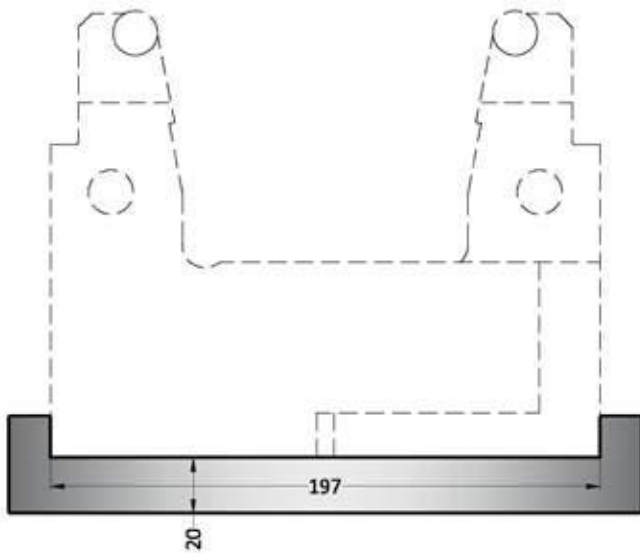

66.125 H=40

500 mm

1000 mm

2000 mm

3000 mm

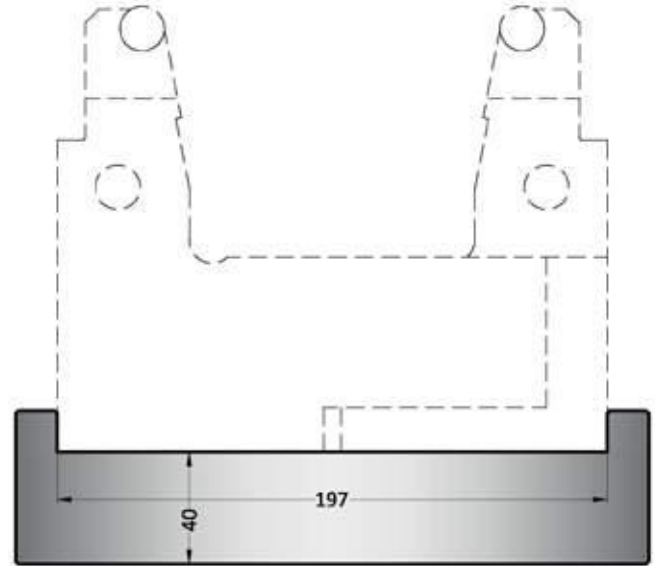

66.125 L (mit Keilleiste) H=20

500 mm

1000 mm

2000 mm

3000 mm

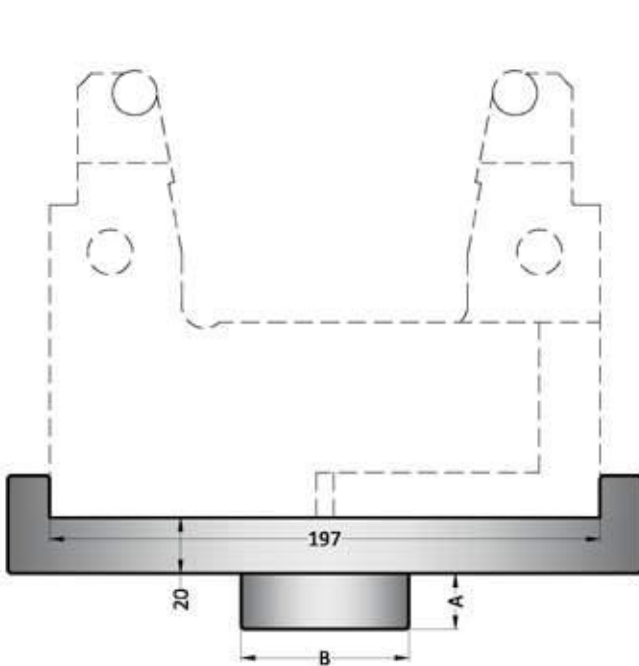

66.125 L (mit Keilleiste) H=40

500 mm

1000 mm

2000 mm

3000 mm

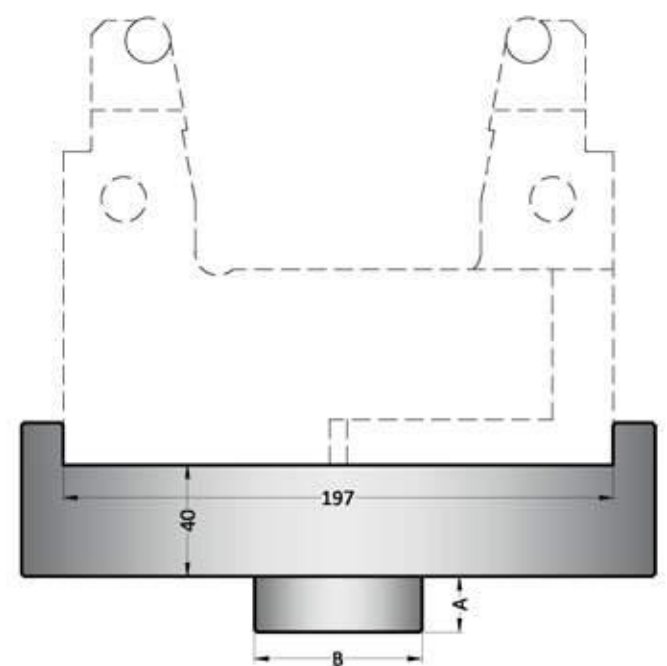

	α	V	T/mt
65.185	max. 60°	65-185mm	200
empf. Materialstärke 6-20mm			

- 250 mm
- 500 mm
- 550 mm
- 1000 mm
- 1050 mm

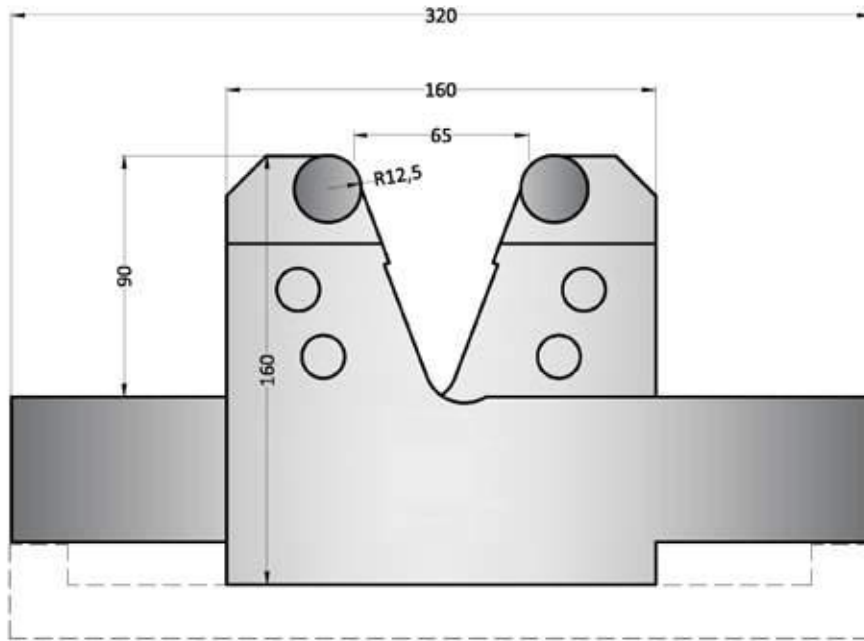

geschlossen /
closed

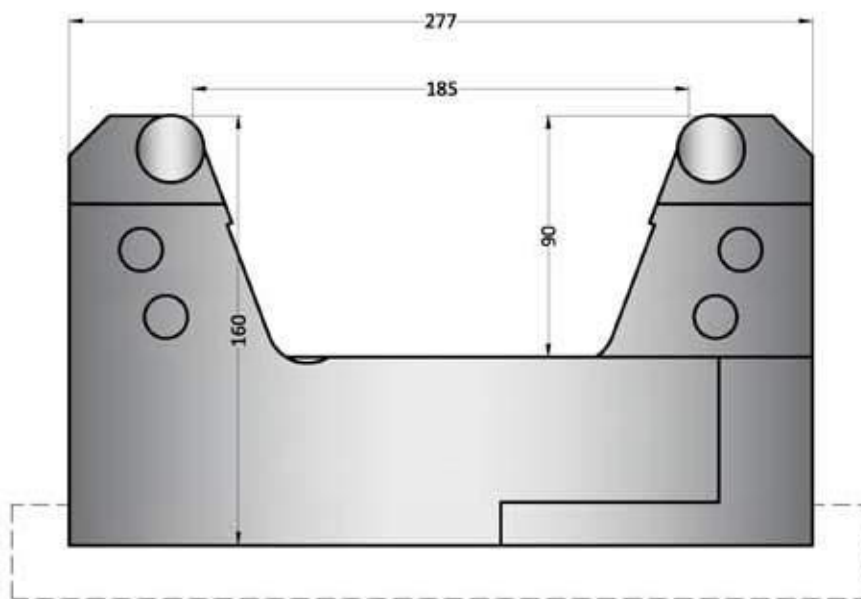

offen /
open

66.185 H=20

500 mm

1000 mm

2000 mm

3000 mm

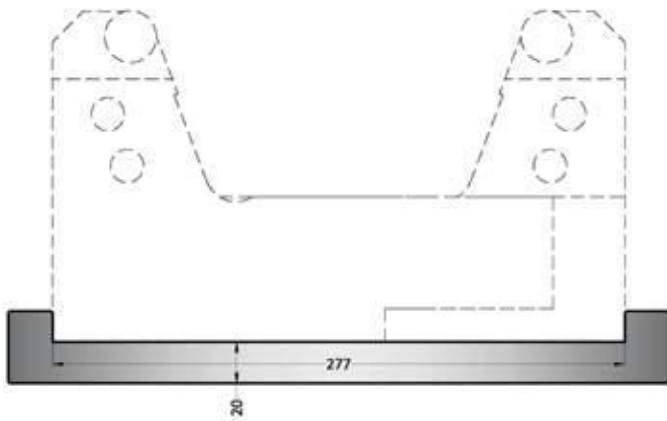

66.185 H=40

500 mm

1000 mm

2000 mm

3000 mm

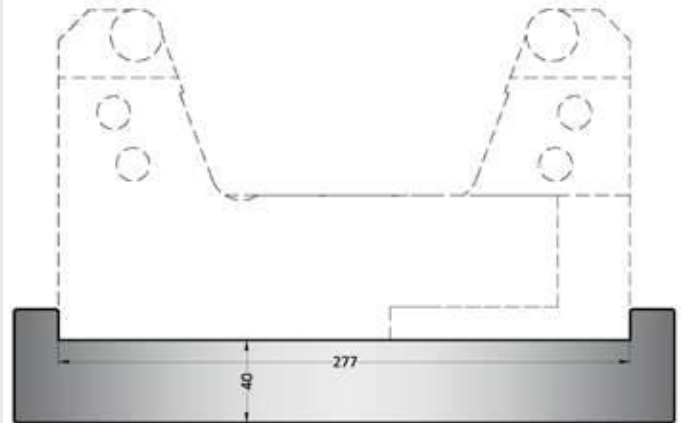

66.185 L (mit Keilleiste) H=20

500 mm

1000 mm

2000 mm

3000 mm

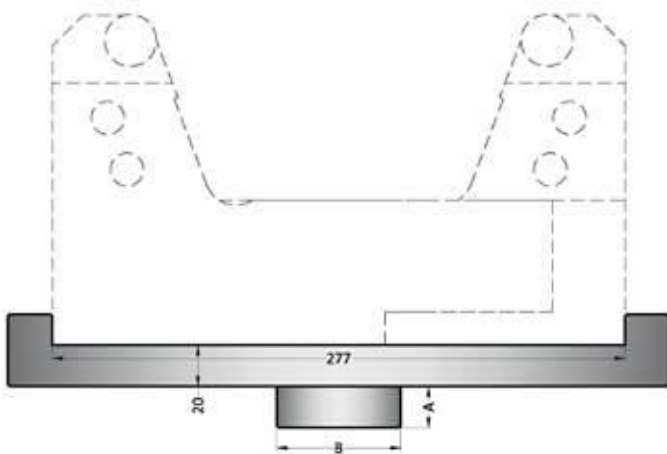

66.185 L (mit Keilleiste) H=40

500 mm

1000 mm

2000 mm

3000 mm

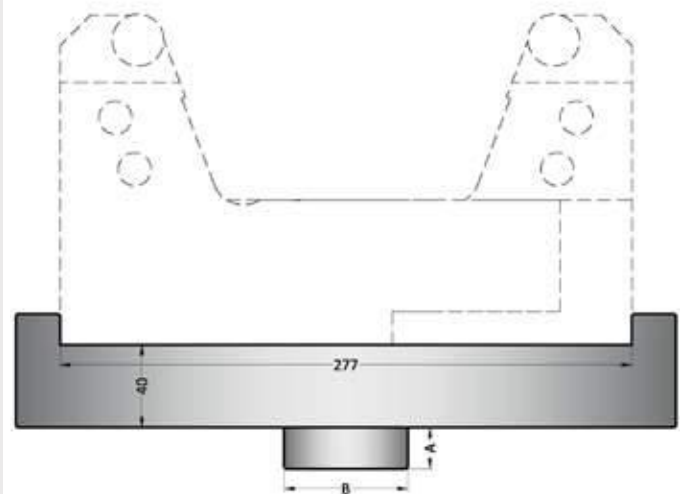

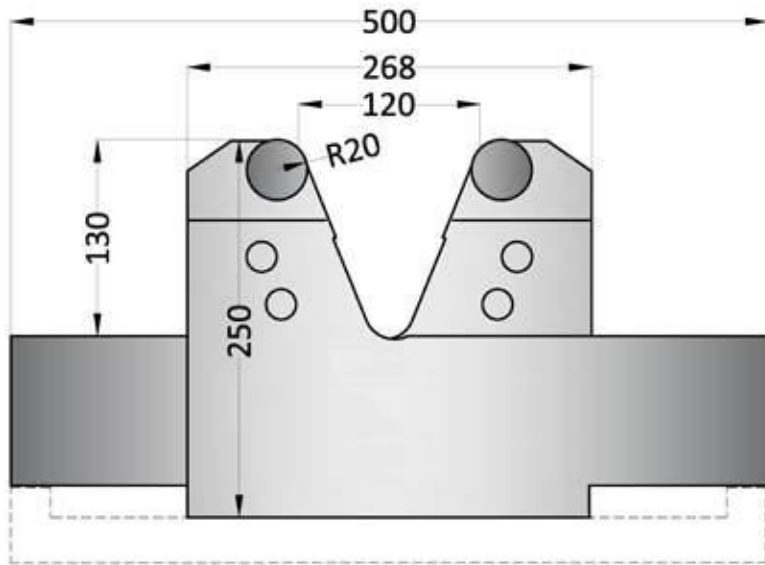

geschlossen /
closed

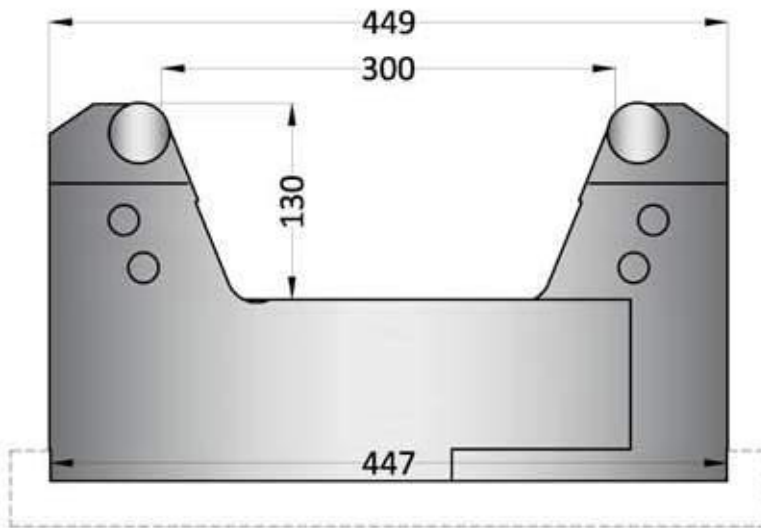

offen /
open

	α	V	T/mt
65.300	max. 60°	120-300mm	400
empf. Materialstärke 8-30mm			

600 mm

Black Line

66.300

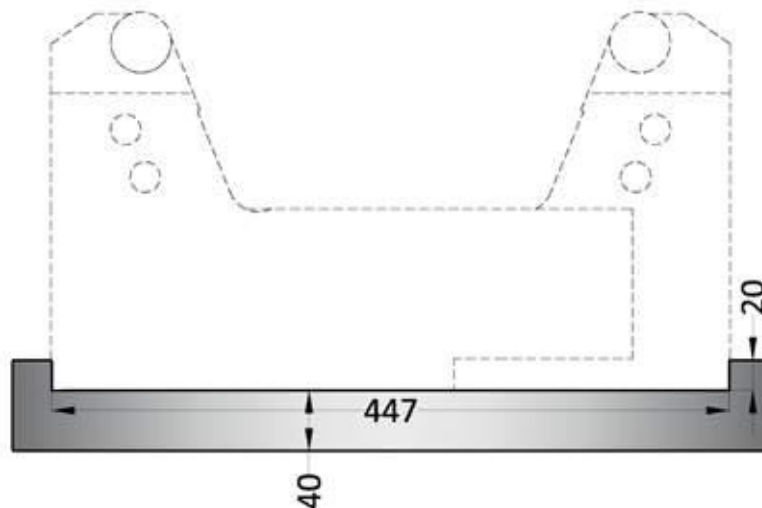

600 mm

1200 mm

2400 mm

3000 mm

	α	V	T/mt
65.400	max. 60°	150-400mm	600
empf. Materialstärke 10-50mm			

600 mm

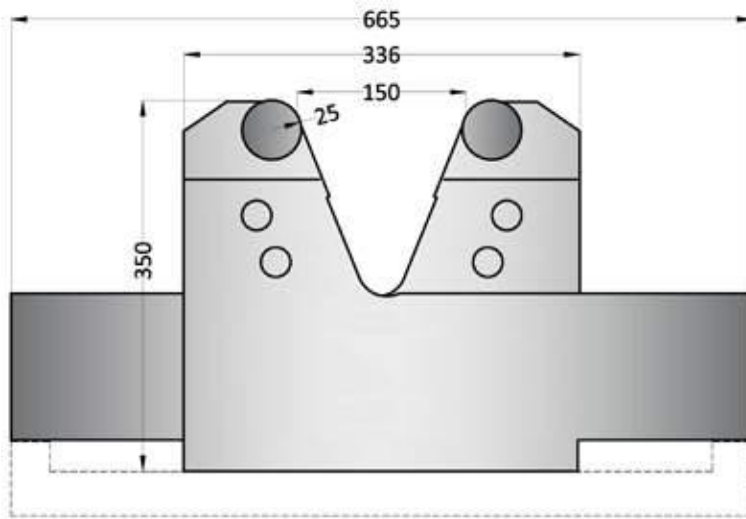

geschlossen /
closed

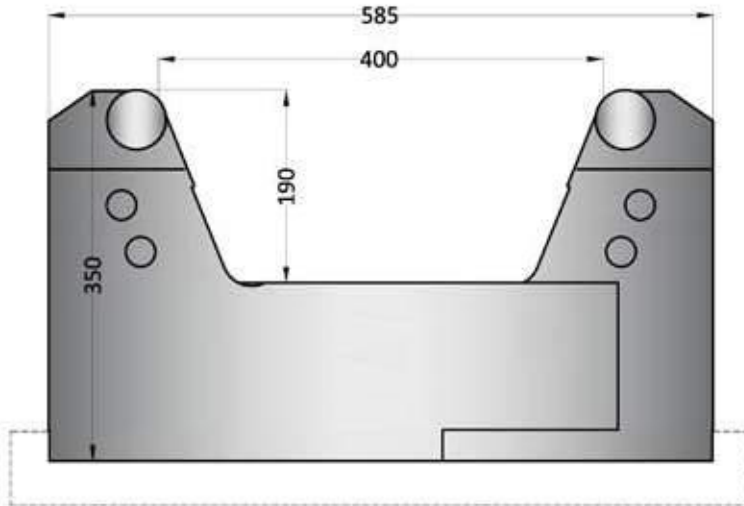

offen /
open

66.400

600 mm

1200 mm

2400 mm

3000 mm

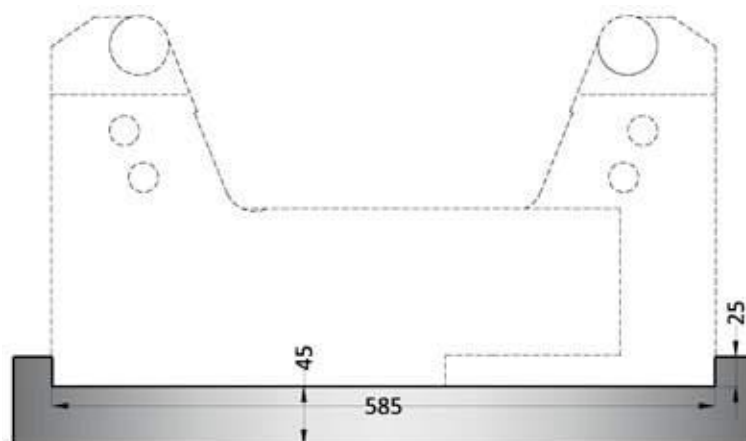

66.000 H=15



für ArtikelNr. 65.125 und 65.185
Leisten im Set:
Breite = 2x je 2/5/10/15/20/30/40/50 mm

- 500 mm
- 1000 mm
- 2000 mm

66.000 H=20

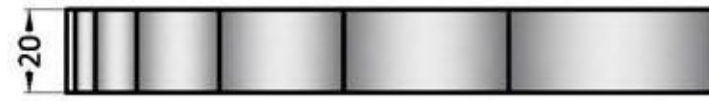

für ArtikelNr. 65.300
Leisten im Set:
Breite = 2x je 2/5/10/15/20/30/40/50/60 mm

- 600 mm
- 1200 mm
- 1800 mm

66.000 H=25



für ArtikelNr. 65.400
Leisten im Set:
Breite = 2x je 2/5/10/15/20/30/40/50/60 mm

- 600 mm
- 1200 mm
- 1800 mm

66.001 H=15

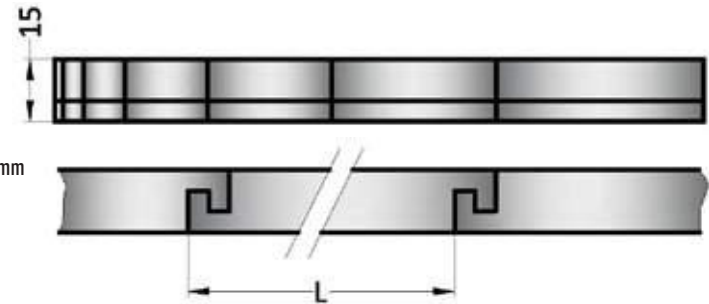

für ArtikelNr. 65.125 und 65.185
Leisten im Set:
Breite = 2x je 2/5/10/15/20/30/40/50 mm

- 510 mm
- 1010 mm
- 2010 mm

66.001 H=20

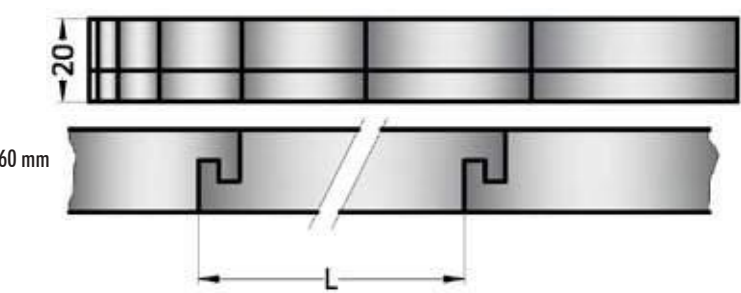

für ArtikelNr. 65.300
Leisten im Set:
Breite = 2x je 2/5/10/15/20/30/40/50/60 mm

- 610 mm
- 1210 mm
- 1810 mm

66.001 H=25

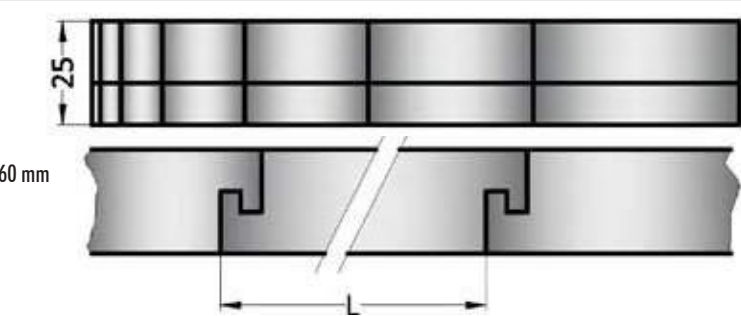

für ArtikelNr. 65.400
Leisten im Set:
Breite = 2x je 2/5/10/15/20/30/40/50/60 mm

- 610 mm
- 1210 mm
- 1810 mm

Black Line

Flexo

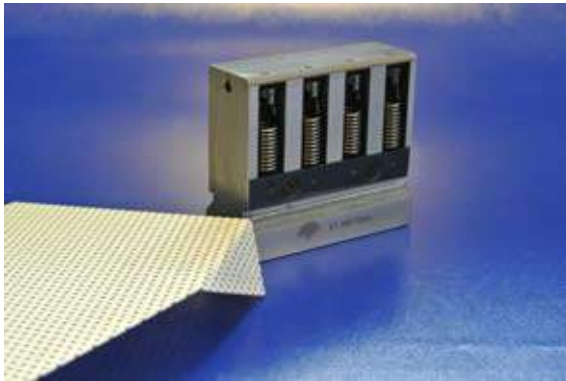

60.101

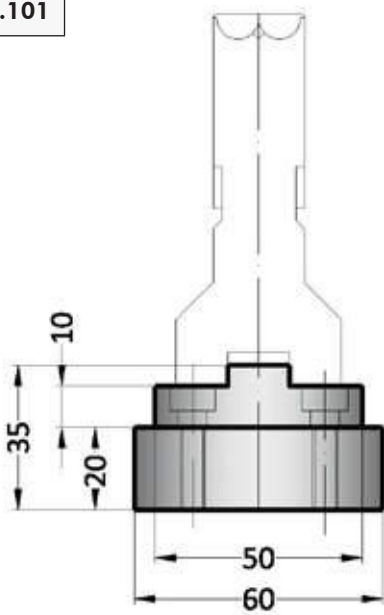

415 mm

835 mm

60.102

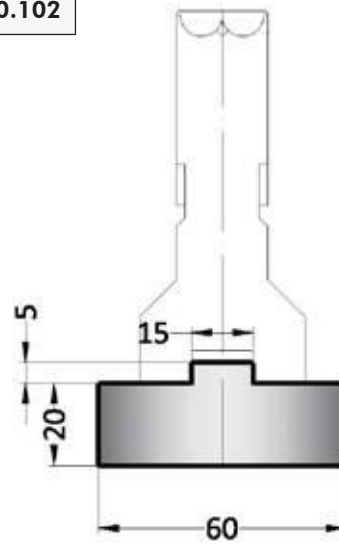

500 mm

1000 mm

60.103

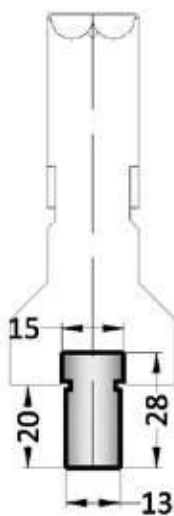

50 mm

90 mm

100 mm

200 mm

60.104

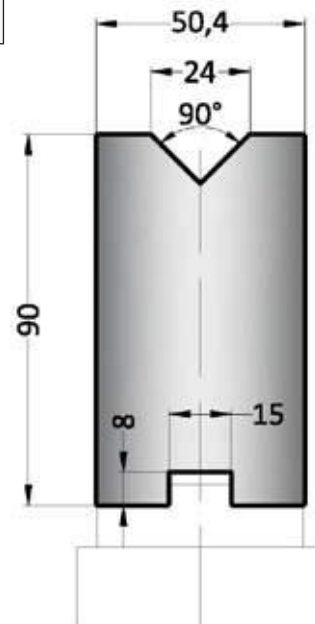

40,4 mm

Justierstück zur exakten Ausrichtung der Aufnahme 60.101 /
adjustment piece for exact alignment of the inclusion 60.101

61.120

50 mm

90 mm

100 mm

200 mm

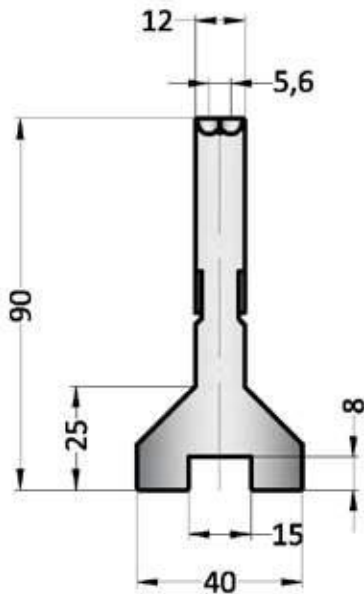

für $t = 0,2-1,2$ mm

61.230

50 mm

90 mm

100 mm

200 mm

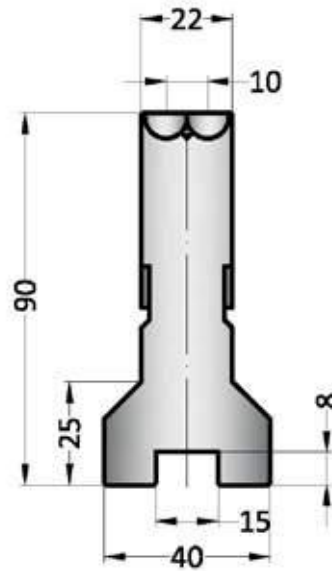

empfohlen: $t = 1,0-2,3$ mm

61.350

50 mm

100 mm

200 mm

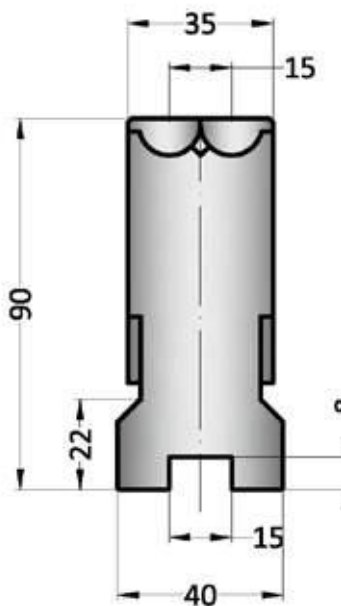

empfohlen: $t = 2,0-3,5$ mm

61.650

50 mm

100 mm

200 mm

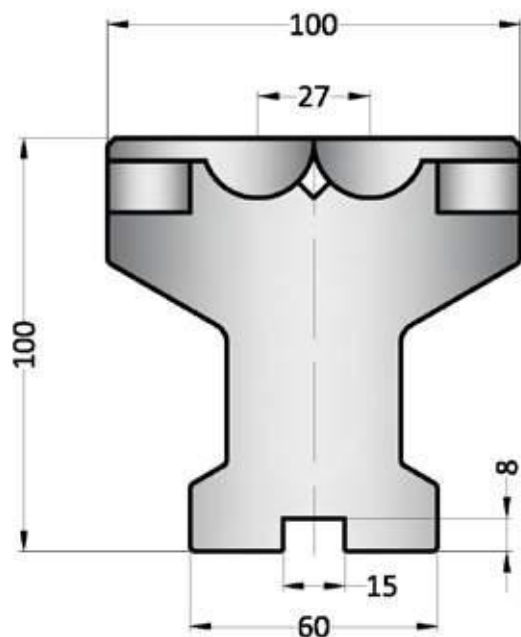

empfohlen: $t = 3,0-6,5$ mm

61.950

50 mm

100 mm

200 mm

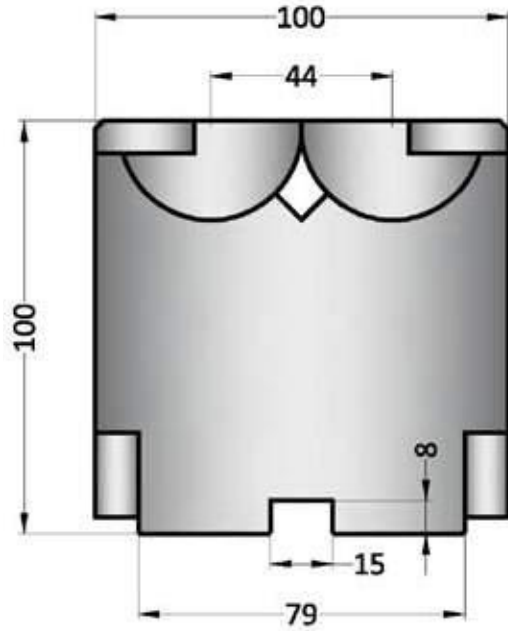

empfohlen: $t = 4,0-9,5$ mm

64.120

50 mm

90 mm

100 mm

200 mm

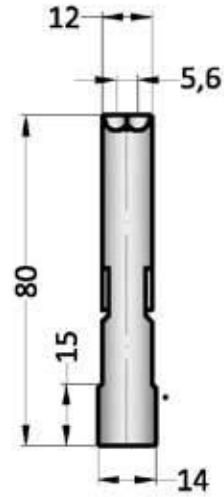

für $t = 0,2-1,2$ mm

64.230

50 mm

90 mm

100 mm

200 mm

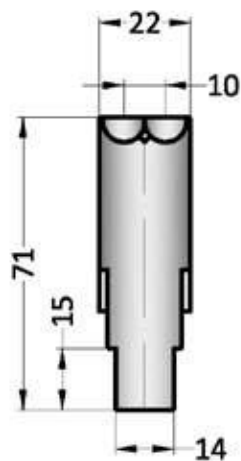

empfohlen: $t = 1,0-2,3$ mm

64.350

50 mm

100 mm

200 mm

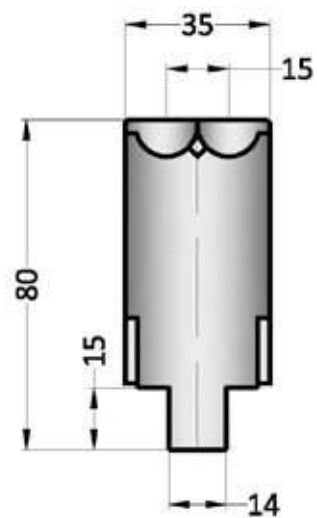

empfohlen: $t = 2,0-3,5$ mm

Richtwerte für Mindestschenkellängen: Stahl

Typ	Stempel	Blechdicke												
		0,5	0,8	1,0	1,5	2,0	2,5	3,0	4,0	5,0	6,0	7,5	9,5	10,0
61.120	R 0,5	2,7	3,2	3,5										
64.120	R 1,0	2,9	3,4	3,6										
61.230	R 0,5		4,9	5,5	6,0	5,8								
64.230	R 1,0		4,7	5,4	6,1	6,6								
61.350	R 1,0		5,6	7,1	8,1	8,3	8,9	9,4						
64.350														
61.500	R 1,0			6,7	8,2	10,4	11,7	13,3	15,1	16,3				
	R 4,0			7,2	9,2	10,9	12,3	13,9	15,8	16,1				
61.950	R 1,0								24,0	29,0	30,0	32,0	33,5	35,0
	R 5,0					26,0	26,0	26,0	30,0	31,0	32,0	35,0	36,0	38,0
	R 10,0	23,0	23,0	23,0	24,0	24,0	25,0	27,0	28,0	31,0	32,0	34,0	38,0	

Richtwerte für Mindestschenkellängen: Edelstahl

Typ	Stempel	Blechdicke												
		0,5	0,8	1,0	1,5	2,0	2,5	3,0	4,0	5,0	6,0	7,5	9,5	10,0
61.120	R 0,5	2,8	3,4	3,7										
64.120	R 1,0	3,0	3,5	3,8										
61.230	R 0,5		5,3	5,7	6,0	6,6								
64.230	R 1,0		5,3	5,7	6,1	6,4								
61.350	R 1,0		6,6	7,4	8,6	8,7	9,0	9,4						
64.350														
61.500	R 1,0			7,6	9,9	11,9	12,9	14,1	15,2					
	R 4,0			8,1	10,6	12,0	13,0	13,8	15,3					
61.950	R 1,0								24,2	29,3	30,4	32,5	34,0	36,0
	R 5,0					26,2	26,2	26,2	30,4	31,5	32,7	35,8	37,0	39,0
	R 10,0	23,1	23,1	23,1	24,2	24,3	25,4	27,7	28,9	32,0	33,2	35,5	39,5	

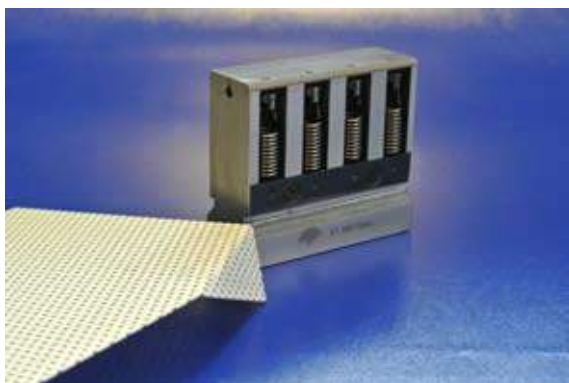

VARIO

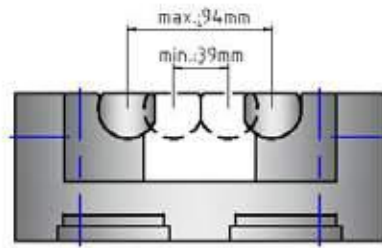

62.094
1000mm
500mm
200mm

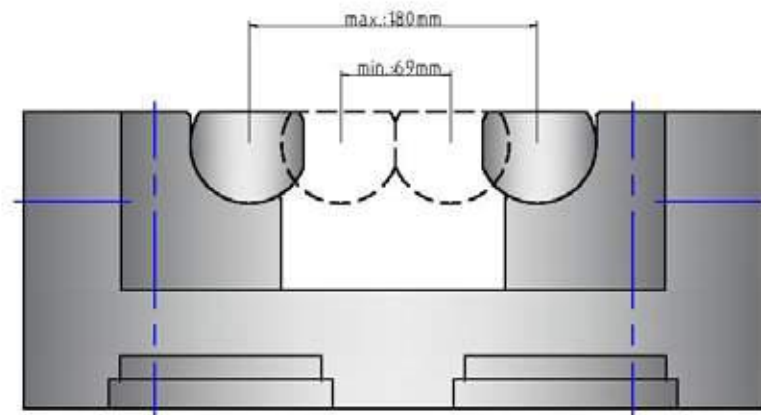

62.180
1000mm
500mm
200mm



62.281
500mm
200mm

konkav Profil für 62094



62.282
500mm
200mm

V-Profil für 62094



62.283
500mm
200mm

flach Profil für 62094



62.181
500mm
200mm

konkav für 62180



62.282
500mm
200mm

V-Profil für 62180



62.283
500mm
200mm

flach-Profil für 62180

Anwendungsbeispiele

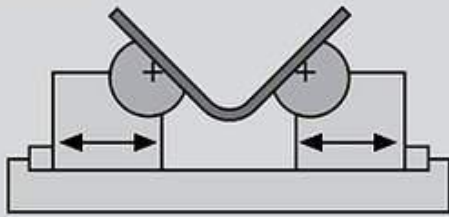

V-Biegen



Rollentyp flach



Ergebnis

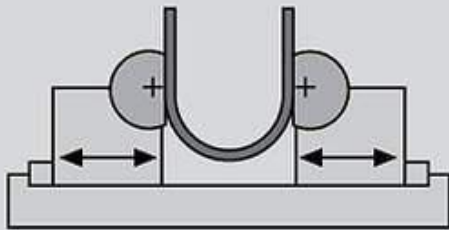

Radius-Biegen

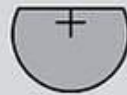

Rollentyp flach



Ergebnis

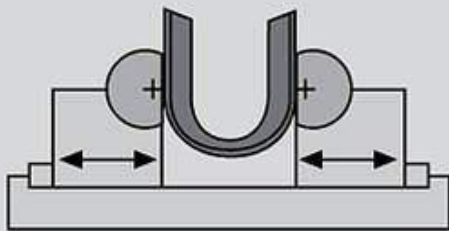

Konisches Formen

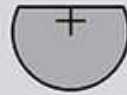

Rollentyp flach



Ergebnis

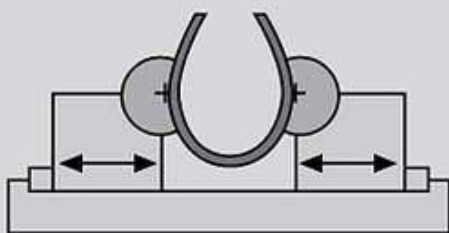

Radius-Biegen/Überbiegen



Rollentyp konkav



Ergebnis

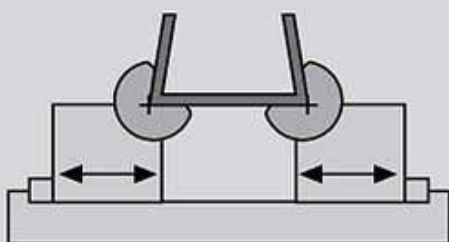

U-Biegen



Rollentyp V

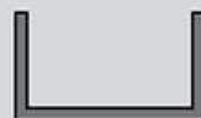

Ergebnis

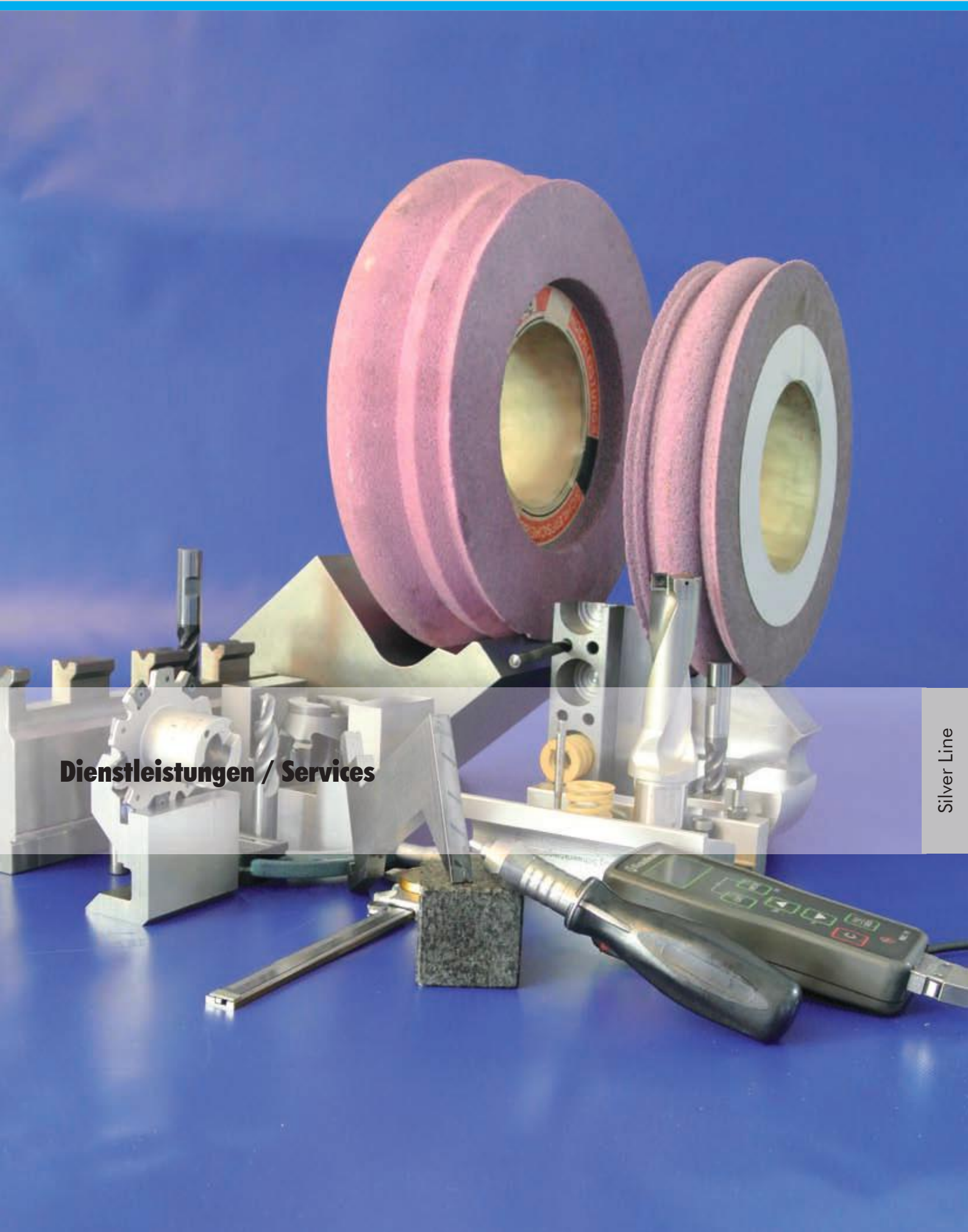

Dienstleistungen / Services

Silver Line

Laserhärten



Laserhärten bis 100mm Breit / Laser-hardening till 100mm widet

Laser hardening



vorher, nachher, Trennschnitt / Einhärtetiefe / before, after, complete separation cut / hardening depth

Westermann24 härtet Neuwerkzeuge und Ihre gebrauchten Werkzeuge mit einer sehr Leistungsstarken Laserhärtenanlage.

Vorteile:

- eine wesentliche Standzeitverlängerung wird erzielt.
- zu erreichende Härte bis zu 60 HRC
- Einhärtetiefen bis zu 8mm
- breite „Härtespuren“ bis zu $b=100\text{mm}$ (z.B. Zudrückfläche/Schwenkbiegewerkzeug)
- prozesssicherer Härtevorgang (Zertifiziert nach DIN EN ISO 9001)

Westermann24 is hardening new and your used tools with a powerful hardening system.

Advantages:

- a significantly endurance extension is reached.
- hardening to reach till 60 HRC
- depth of hardening till 8mm
- wide hardening tracks till $b=100\text{mm}$ (f.e. pressing shut area/ folding tool)
- process safe hardening process (certified to DIN EN ISO 9001)

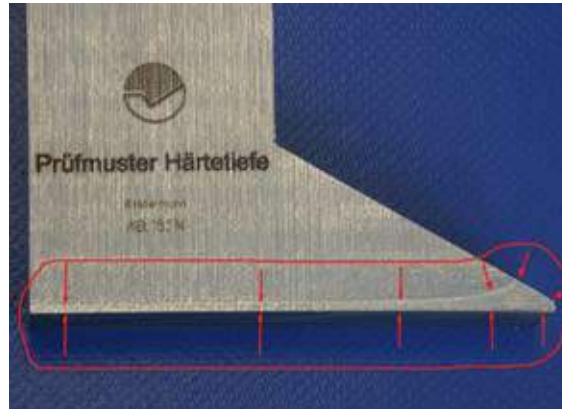

Im Sägequerschnitt ist die Einhärtetiefe am Prüfmuster (wie hier im Bild) gut zu erkennen. / in the sawing cross section is the depth of hardening at the sample (as the picture) easy to recognize.

Nach Terminabsprache schleifen und härteten wir Ihre gebrauchten Werkzeuge innerhalb von 1 Arbeitstag

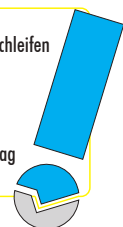

Nachschleifen und härten Ihrer Abkantwerkzeuge

Lieferzeit:
nach Terminabsprache 1 Arbeitstag

Regrinding and hardening of your press brake tools

delivery period:
after prior agreement regarding the date 1 workday



hohe Wiederholgenauigkeit durch **CNC-Profileschleifen** / high repetition exactness by **CNC-grinding of the profile**

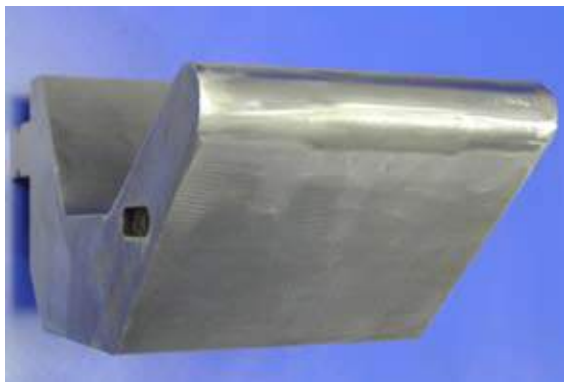

Vorher / before

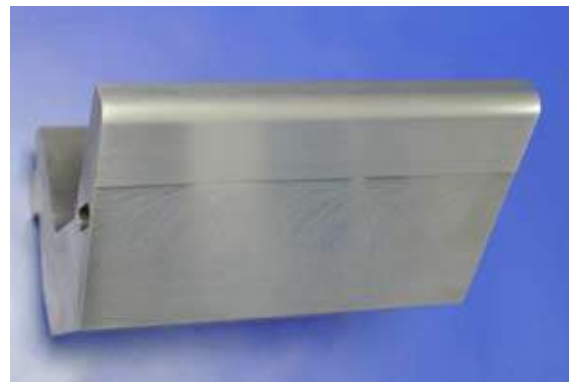

Nacher / after

CNC-Fräsen bis 5000mm

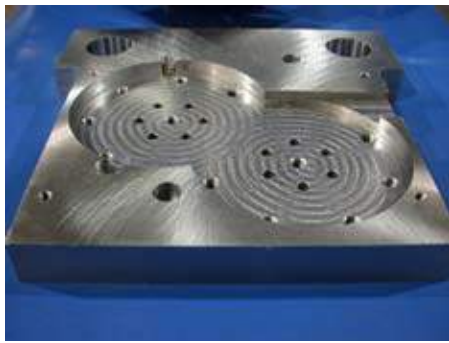

Säulengestell / column frame

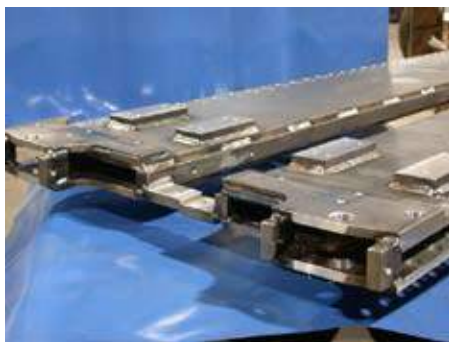

Maschinenkörper / machine frame

CNC-grinding till to 5000mm

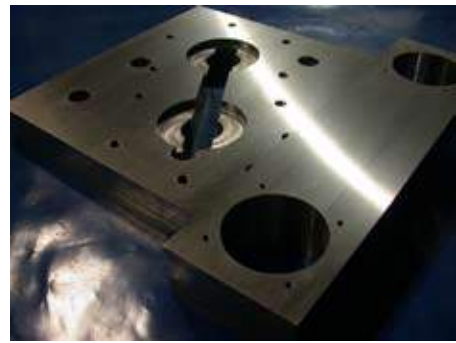

Grundplatte / baseplate



Kurvenscheibe/Flachschleifen/Fräsen / cam plate/straight wheels/milling

Flach und Profil – Schleifen bis 6500mm



Führungsbahnen / guiding paths

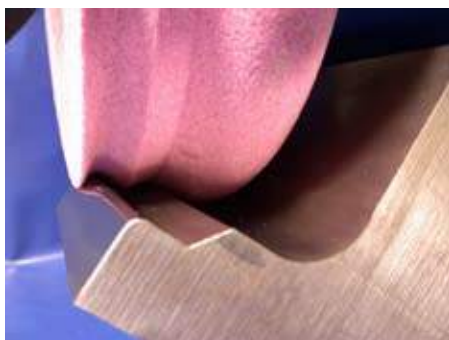

Profilschleifen / profile milling

Flat sheet and profile – grinding till to 6500mm

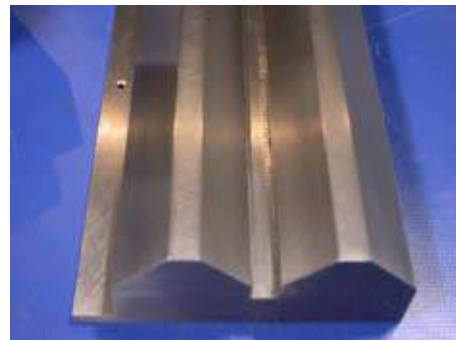

Dachführung / roof maintenance

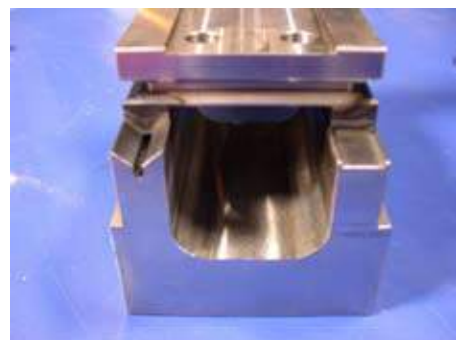

Flach – Dachführung / flat – roof maintenance

Haben Sie jetzt Zeit für Ihre Abkantpresse?



ausgebaute Oberwange / assembled upper beam

Problem:

Eine abgenutzte Werkzeugaufnahme ist Ursache für schlechte Qualität Ihrer Kantprodukte.

Unsere Lösung:

Westermann24 erneuert die Werkzeugaufnahme mittels Nacharbeit oder den Einsatz von Verschleißleisten, die bei wiederkehrendem Verschleiß nur ausgewechselt werden müssen.

Lieferzeit: 1-2 Werktage nach Terminabsprache



eingesetzte Verschleißleisten / used exchangeable wearbars

Do you have time for your press brake?



nachsetzen der Aufnahme / repositioning of the holder

Problem:

The cause of bad quality of your press brake products is a worn toolholder.

Our solution:

Westermann24 renews the toolholder by reworking or the using of exchangeable wearbars.

delivery period: 1-2 workdays after fixing an appointment



nachgeschliffene Spannelemente / regrounded clamping elements

Reibungsarme Beschichtungen

Verbessern Sie die Qualität Ihrer Produkte durch beschichtete Werkzeuge.

Das Problem:

- Kaltaufschweißungen am Werkzeug durch Alu- und verzinktem Stahlblech
- Edelstahl – Kanteile die von Hand aufwendig nachpoliert werden müssen (ferritische Abriebe)
- Riefen und Kratzer auf dem Blech
- Werkzeugverschleiß, Werkzeugpflege



Kaltaufschweißung durch Abrieb

Unsere Lösung:

Westermann24 bietet hier eine metallbasierende Beschichtung, die nur wenige tausendstel Millimeter dünn, aber härter als Stahl, extrem reibungsarm, verschleißfest, und chemisch inert ist. Diese Beschichtung erfolgt als letzter Fertigungsschritt.

Vorteile:

- Niedrigere Gleitreibungszahl 0,1-0,15µ/G
- Standzeitverlängerung zu gehärtet geschliffenen Werkzeugen (keine Kaltaufschweißungen)
- Hohe Abriebfestigkeit bis zu einer Mikrohärtigkeit von 3000 HV Vickers (zum Vergleich: Ein einseitig gehärtetes Werkzeug hat 60 HRC / Rockwell = 715 HV / Vickers)

Low friction coatings

Coated tools optimize the quality of your products.

The Problem:

- cold bondings at the tool because of aluminium and zinc plated steel sheets
- folding parts of stainless-steel which have to be hand polished. (ferrite abrasion)
- Scratches and Grooves at the sheet metal
- wearing of tools, calibrating tools



Our solution:

Westermann24 provides at this point a metal-based coating, only a few nanometers thick, but harder than steel, extremely low friction, wear resistant, and chemical inert. This coating is the last step of production.

Advantages:

- low number of sliding friction 0,1-0,15µ/G
- extended lifetime to ground and hardened tools (no cold bondings)
- high abrasion resistance up to mikrohardness of 3000 HV Vickers (comparison: A case hardened tool has 60 HRC / Rockwell = 715 HV / Vickers)

Art.-Nr.	S/P
1.01.274	43
1.01.275	44
1.01.279	15
1.02.070	76
1.02.100	76
1.02.130	76
1.02.160	76
1.02.190	77
1.02.220	77
1.02.241	82
1.02.242	82
1.02.243	82
1.02.244	83
1.02.245	83
1.02.246	78
1.02.247	79
1.02.248	80
1.02.249	81
1.03.010	133
1.03.040	133
1.03.070	134
1.03.090	134
1.03.110	134
1.03.154	135
1.03.155	136
1.03.156	137
1.03.162	138
1.03.163	139
1.03.168	140
1.03.169	141
1.03.175	133
1.04.246	86
1.04.248	87
1.04.252	99
1.04.253	100
1.05.010	119
1.05.040	120
1.05.070	119
1.05.100	118
1.05.120	118
1.05.132	118

Art.-Nr.	S/P
1.05.133	120
1.07.010	153
1.07.040	153
1.07.061	154
1.07.062	154
1.07.063	157
1.07.064	157
1.07.065	157
1.07.066	158
1.07.067	158
1.07.070	155
1.07.071	156
1.08.182	54
1.08.189	72
1.08.190	72
1.09.010	106
1.09.030	103
1.09.050	103
1.09.061	104
1.09.062	105
1.09.063	115
1.09.064	115
1.09.065	115
1.09.066	116
1.09.067	116
2.05.009	127
2.05.009	208
2.05.010	127
2.05.010	208
2.05.060	127
2.05.090	128
2.05.120	128
2.05.180	127
2.05.201	129
2.05.202	129
2.05.203	129
2.05.204	129
2.05.205	129
2.05.206	129
2.05.207	129
2.05.208	129

Art.-Nr.	S/P
2.05.209	129
2.05.210	129
2.05.211	129
2.05.212	129
2.05.213	129
2.05.214	129
2.05.215	130
2.05.216	130
2.05.217	130
2.05.218	130
2.05.219	130
2.05.220	130
2.05.221	130
2.05.222	130
2.05.223	130
2.05.224	130
2.06.010	208
2.07.010	208
2.09.190	209
2.09.210	209
2.09.221	113
2.09.222	113
2.09.223	113
2.09.224	113
2.09.225	113
2.09.226	113
2.09.227	113
2.09.228	113
2.09.229	113
2.09.230	113
2.09.231	113
2.09.232	113
2.09.233	113
2.09.234	113
2.09.246	115
2.09.247	115
2.09.248	115
2.09.249	116
2.09.250	116
2.10.211	95
2.10.212	95

Art.-Nr.	S/P
2.10.213	95
2.10.214	95
2.10.215	95
2.10.217	95
2.10.218	95
2.10.219	95
2.10.220	95
2.10.221	95
2.10.222	95
2.10.223	95
2.10.224	95
2.11.142	66
2.11.143	66
2.11.144	65
2.11.145	65
2.11.146	65
2.11.147	65
2.11.148	65
2.11.149	65
2.11.150	65
2.11.151	65
2.11.152	65
2.11.153	65
2.11.164	65
2.12.164	68
2.12.165	68
2.12.166	68
2.12.167	68
2.12.168	68
2.12.169	68
2.12.170	68
2.12.171	68
2.12.172	68
2.12.173	68
2.12.174	68
2.12.182	68
2.12.183	68
2.12.184	68
2.12.185	68
2.12.186	72
2.12.186	99

Art.-Nr.	S/P
2.12.187	72
2.12.187	100
2.13.310	34
2.13.311	34
2.13.315	34
2.13.316	34
2.13.317	34
2.13.320	33
2.13.321	33
2.13.322	33
2.13.323	33
2.13.324	33
2.13.325	33
2.13.326	33
2.13.327	33
2.14.309	32
2.14.309	209
2.14.310	37
2.14.311	37
2.14.312	37
2.14.316	37
2.14.317	37
2.14.318	37
2.14.322	37
2.14.323	37
2.14.324	36
2.14.325	36
2.14.326	36
2.14.327	36
2.14.328	36
2.14.329	36
2.14.330	36
2.14.331	36
2.14.332	36
2.14.333	36
2.14.334	36
2.14.335	43
2.14.336	44
2.15.070	147
2.15.100	147
2.15.101	147

Art.-Nr.	S/P
2.15.102	147
2.15.105	148
2.15.106	148
2.15.107	148
2.15.108	148
2.15.109	148
2.15.110	148
2.15.114	149
2.15.115	149
2.15.116	149
2.15.117	149
2.15.118	149
2.15.119	149
2.15.120	147
2.15.121	147
2.16.100	147
2.16.101	147
2.16.102	147
2.16.105	148
2.16.106	148
2.16.107	148
2.16.108	148
2.16.109	148
2.16.110	148
2.16.111	148
2.16.112	148
2.16.116	149
2.16.117	149
2.16.118	149
2.16.119	149
2.16.120	149
2.16.121	149
2.16.122	149
2.16.123	149
2.16.125	147
2.16.126	147
2.16.127	147
2.17.010	147
2.17.011	147
2.17.012	147
2.17.015	148

Art.-Nr.	S/P	Art.-Nr.	S/P	Art.-Nr.	S/P	Art.-Nr.	S/P	Art.-Nr.	S/P	Art.-Nr.	S/P
2.17.016	148	2.20.021	67	2.23.023	38	2.26.023	151	4.07.004	206	10.300	26
2.17.017	148	2.20.022	67	2.23.024	38	2.26.024	151	4.08.001	206	10.301	26
2.17.018	148	2.21.004	69	2.23.025	38	2.26.025	151	5.01.001	206	10.302	26
2.17.019	148	2.21.005	69	2.23.026	38	2.26.026	151	5.01.002	206	10.303	26
2.17.020	148	2.21.006	69	2.24.011	114	4.01.001	198	5.01.003	206	10.304	26
2.17.021	148	2.21.007	69	2.24.011	114	4.01.002	198	10.115	25	10.305	26
2.17.022	148	2.21.008	69	2.24.012	114	4.01.003	198	10.116	25	10.306	26
2.17.023	148	2.21.009	69	2.24.013	114	4.01.004	198	10.136	17	10.307	26
2.17.026	149	2.21.010	69	2.24.014	114	4.01.005	199	10.142	16	10.308	26
2.17.027	149	2.21.011	69	2.24.015	114	4.01.006	199	10.143	16	10.309	26
2.17.028	149	2.21.017	69	2.24.016	114	4.01.007	199	10.150	12	10.310	26
2.17.029	149	2.21.018	69	2.24.017	114	4.02.001	199	10.152	7	10.311	26
2.17.030	149	2.21.019	69	2.24.018	114	4.02.002	199	10.153	7	10.312	26
2.17.031	149	2.21.020	69	2.25.011	131	4.02.003	200	10.154	9	10.313	26
2.17.032	149	2.21.021	69	2.25.012	131	4.02.004	200	10.155	9	10.314	26
2.17.033	149	2.21.022	69	2.25.013	131	4.02.005	200	10.156	9	10.315	26
2.17.034	147	2.21.023	69	2.25.014	131	4.02.006	201	10.157	9	10.316	26
2.17.034	149	2.21.024	69	2.25.015	131	4.02.007	201	10.170	7	10.317	26
2.17.035	147	2.22.010	35	2.25.016	131	4.03.001	201	10.173	7	10.318	26
2.17.036	147	2.22.011	35	2.25.017	131	4.03.002	201	10.174	7	10.319	26
2.18.010	210	2.22.012	35	2.25.018	131	4.03.003	201	10.175	7	10.320	26
2.18.011	210	2.22.013	35	2.25.019	131	4.03.005	201	10.176	7	10.321	26
2.19.010	96	2.22.014	35	2.25.020	131	4.03.006	202	10.180	24	10.322	26
2.19.011	96	2.22.015	35	2.25.021	131	4.03.007	202	10.181	24	10.323	26
2.19.012	96	2.22.016	35	2.25.022	131	4.03.008	202	10.182	24	10.324	26
2.19.013	96	2.22.017	35	2.25.023	131	4.04.001	202	10.183	24	10.325	26
2.19.014	96	2.22.018	35	2.25.024	131	4.04.002	202	10.184	24	10.400	21
2.19.015	96	2.22.019	35	2.25.025	131	4.04.003	203	10.185	24	10.500	16
2.19.016	96	2.22.141	66	2.25.026	131	4.04.004	203	10.186	24	10.501	9
2.19.017	96	2.23.011	38	2.26.011	150	4.04.005	203	10.187	24	10.502	9
2.19.018	96	2.23.012	38	2.26.012	150	4.04.006	203	10.188	24	10.503	8
2.20.011	67	2.23.013	38	2.26.013	150	4.05.001	204	10.190	25	10.504	8
2.20.012	67	2.23.014	38	2.26.014	150	4.05.002	204	10.191	25	10.505	12
2.20.013	67	2.23.015	38	2.26.015	150	4.05.003	204	10.256	8	10.510	14
2.20.014	67	2.23.016	38	2.26.016	150	4.05.004	204	10.257	8	10.511	18
2.20.015	67	2.23.017	38	2.26.017	150	4.05.005	205	10.259	8	10.512	12
2.20.016	67	2.23.018	38	2.26.018	150	4.06.001	205	10.260	8	10.514	17
2.20.017	67	2.23.019	38	2.26.019	151	4.06.002	205	10.261	8	10.515	18
2.20.018	67	2.23.020	38	2.26.020	151	4.07.001	205	10.262	8	10.516	16
2.20.019	67	2.23.021	38	2.26.021	151	4.07.002	205	10.263	8	10.517	16
2.20.020	67	2.23.022	38	2.26.022	151	4.07.003	206	10.264	8	10.520	14

10.626	8	11.820	13	14.313	85	15.680	54	20.160	33	20.295	30
10.650	8	11.830	13	14.330	84	15.680 X	54	20.200	29	20.296	30
10.710	17	11.835	12	14.333	85	15.700	51	20.201	29	20.297	34
10.720	17	11.840	10	14.353	85	15.700 X	51	20.202	30	20.298	34
10.857	7	11.848	13	14.363	85	15.710	51	20.203	30	20.299	34
10.861	8	11.849	13	14.383	85	15.710 X	51	20.204	30	20.300	34
11.100	7	11.853	7	14.400	88	15.720	52	20.205	30	20.301	34
11.101	7	11.855	8	14.410	87	15.720 X	52	20.208	32	20.303	45
11.105	9	11.858	8	14.420	87	15.730	52	20.210	33	20.303 P	47
11.106	9	11.863	9	14.430	87	15.730 X	52	20.211	33	20.305	45
11.107	9	11.864	9	14.440	86	15.750	53	20.212	33	20.305 P	47
11.108	9	11.865	9	14.450	86	15.750 X	53	20.213	33	20.306	29
11.145	7	11.866	9	14.460	86	15.760	58	20.214	33	20.308	34
11.146	9	11.867	9	14.908	98	15.760 X	58	20.215	33	20.309	33
11.147	9	11.868	8	14.910	98	15.761	21	20.216	33	20.310	33
11.148	13	11.869	12	14.912	98	15.763	21	20.217	33	20.311	34
11.149	13	11.870	7	15.010	61	15.765	21	20.229	30	20.316	29
11.151	9	14.010	75	15.010 X	61	15.765	58	20.230	30	20.317	34
11.158	18	14.020	75	15.014	61	15.766	21	20.231	45	20.318	34
11.200	7	14.030	75	15.018	61	15.767	21	20.231 P	47	20.319	34
11.201	7	14.040	75	15.050	59	15.768	21	20.235	30	20.320	34
11.228	7	14.050	75	15.310	52	15.769	21	20.237	32	20.321	34
11.230	7	14.060	75	15.310 X	52	15.774	21	20.243	33	20.322	34
11.231	7	14.080	89	15.320	52	15.776	21	20.244	33	20.323	34
11.232	7	14.085	89	15.320 X	52	15.790	56	20.245	33	20.325	34
11.233	12	14.090	89	15.330	51	15.800	57	20.246	33	20.327	33
11.258	19	14.095	89	15.330 X	51	15.800 X	57	20.258	33	20.328	34
11.506	14	14.101	84	15.370	51	15.902	71	20.264	45	20.329	34
11.514	19	14.105	84	15.370 X	51	15.904	71	20.264 P	47	20.330	34
11.528	19	14.106	84	15.450	53	15.905	71	20.267	30	20.331	34
11.530	19	14.209	84	15.450 X	53	16.010	110	20.271	178	20.332	34
11.540	20	14.210	84	15.610	55	16.050	108	20.272	178	20.333	34
11.550	42	14.211	84	15.610 X	55	16.070	107	20.273	178	20.334	34
11.554	42	14.250	91	15.620	55	17.010	124	20.274	178	20.336	29
11.560	42	14.251	91	15.620 X	55	17.050	122	20.275	31	20.338	30
11.660	9	14.252	91	15.630	54	17.070	121	20.276	31	20.339	31
11.670	12	14.280	88	15.630 X	54	17.510	144	20.277	31	20.344	31
11.750	17	14.281	88	15.635	53	17.550	143	20.278	31	20.345	31
11.780	18	14.282	88	15.635 X	53	17.570	142	20.279	31	20.346	31
11.800	11	14.300	84	15.670	53	20.125	33	20.280	31	20.347	31
11.810	20	14.303	85	15.670 X	53	20.125	36	20.287	29	20.348	31

Art.-Nr.	S/P	Art.-Nr.	S/P	Art.-Nr.	S/P	Art.-Nr.	S/P	Art.-Nr.	S/P	Art.-Nr.	S/P
20.349	31	20.418	30	21.412	37	24.009	95	25.403	66	26.308	113
20.350	32	20.420	34	21.416	37	24.010	95	25.404	66	26.310	113
20.351	37	20.425	34	21.420	37	24.011	95	25.405	66	26.316	113
20.352	37	20.438	31	21.425	37	24.012	95	25.406	66	26.320	113
20.353	37	20.440	34	21.506	36	24.013	95	25.407	66	26.321	113
20.354	37	20.478	31	21.508	36	24.014	95	25.408	66	26.324	113
20.361	36	20.484	34	21.510	36	24.015	95	25.409	66	26.706	113
20.362	36	20.494	34	21.512	36	24.016	95	25.421	66	26.708	113
20.363	36	20.506	33	21.516	36	24.017	95	25.422	66	26.710	113
20.364	36	20.508	33	21.520	36	24.018	95	25.423	66	26.712	113
20.370	34	20.510	33	21.525	36	24.019	95	25.424	66	26.716	113
20.371	33	20.512	33	21.600	48	24.035	95	25.425	66	26.720	113
20.380	34	20.516	33	21.806	36	24.040	95	25.601	68	26.724	113
20.381	36	20.520	33	21.808	36	24.050	95	25.602	68	26.730	113
20.382	36	20.525	33	21.810	36	24.060	95	25.603	68	26.740	113
20.383	36	20.550	42	22.002	41	25.100	65	25.604	68	26.750	113
20.384	36	20.554	42	22.005	70	25.101	65	25.605	68	26.760	113
20.385	36	20.560	42	22.010	39	25.102	65	25.606	68	26.780	113
20.386	37	20.650	34	22.306	40	25.103	65	25.621	68	26.794	113
20.387	37	20.680	34	22.308	40	25.104	65	25.622	68	26.797	113
20.388	37	20.701	195	22.310	40	25.105	65	25.623	68	32.306	41
20.389	37	20.703	195	22.312	40	25.106	65	25.624	68	32.306	70
20.390	37	20.705	195	22.316	40	25.111	65	25.625	68	32.308	41
20.391	37	20.707	195	22.320	40	25.112	65	25.626	68	32.310	41
20.392	37	20.709	195	22.325	40	25.113	65	25.627	68	32.406	41
20.393	37	20.720	194	22.804	40	25.114	65	25.628	68	32.408	41
20.394	37	20.725	194	22.806	40	25.115	65	25.629	68	32.410	41
20.395	37	20.732	195	22.808	40	25.116	65	25.630	68	32.412	41
20.396	37	20.806	33	22.810	40	25.201	65	25.901	68	32.606	41
20.397	37	20.808	33	22.812	40	25.202	65	25.902	68	32.608	41
20.398	37	20.810	33	22.816	40	25.203	65	25.903	68	32.610	41
20.399	37	20.820	32	22.820	40	25.204	65	25.904	68	32.612	41
20.400	29	20.830	32	22.825	40	25.205	65	25.905	68	32.616	41
20.401	37	21.202	30	24.001	95	25.206	65	25.906	68	32.806	41
20.402	37	21.207	32	24.002	95	25.207	65	25.907	68	32.808	41
20.403	37	21.209	32	24.003	95	25.208	65	25.908	68	32.810	41
20.406	34	21.275	31	24.004	95	25.209	65	25.909	68	32.812	41
20.408	34	21.276	31	24.005	95	25.210	65	25.992	71	32.816	41
20.410	34	21.406	37	24.006	95	25.400	66	25.994	71	34.180	178
20.412	34	21.408	37	24.007	95	25.401	66	25.995	71	34.190	178
20.416	34	21.410	37	24.008	95	25.402	66	26.306	113	34.195	178

Art.-Nr.	S/P
34.280	178
34.290	178
34.295	178
34.380	178
34.390	178
34.395	178
34.480	178
34.490	178
34.495	178
35.180	178
35.190	178
35.195	178
35.280	178
35.290	178
35.295	178
35.380	178
35.390	178
35.395	178
35.480	178
35.490	178
35.495	178
40.419	22
40.500	23
40.510	23
40.511	23
40.515	23
40.516	23
40.520	23
40.521	23
40.525	23
40.526	23
40.530	23
40.535	23
40.540	23
40.545	23
40.550	23
40.555	23
40.560	23
40.565	23
40.570	23
40.575	23

Art.-Nr.	S/P
40.580	23
40.590	23
40.610	23
40.611	23
40.612	23
40.613	23
40.614	23
40.615	23
50.400	186
50.410	186
50.415	186
50.430	182
50.440	187
50.445	187
50.450	183
50.470	183
50.490	184
50.500	188
50.501	188
50.502	189
50.503	189
50.512	191
50.529	190
50.551	190
50.571	190
50.666	191
50.667	191
50.668	191
50.669	191
50.671	185
50.673	191
50.674	191
50.705	191
50.706	191
50.707	191
50.708	191
50.710	191
50.900	190
50.903	190
50.905	190
50.910	190

Art.-Nr.	S/P
50.959	185
50.970	183
50.980	182
50.981	182
50.982	186
50.983	183
50.985	185
50.990	183
50.991	183
50.992	184
50.993	184
50.994	185
50.996	184
50.997	184
50.998	184
60.101	219
60.102	219
60.103	219
60.104	219
60.680	182
60.681	182
60.682	182
60.683	182
60.910	192
60.919	192
60.920	192
60.925	192
60.930	192
60.935	192
60.940	193
60.945	193
60.950	193
60.955	193
61.120	220
61.230	220
61.350	220
61.650	220
61.950	221
62.094	223
62.180	223
62.181	223

Art.-Nr.	S/P
62.281	223
62.282	223
62.283	223
64.120	221
64.230	221
64.350	221
65.125	212
65.185	214
65.300	216
65.400	217
66.000	218
66.001	218
66.125	213
66.185	215
66.300	216
66.400	217

Kontakt / Contact

Westermann24
Gewerbestr. 1-3
33818 Leopoldshöhe-Asemissen
Germany

Tel: +49 (0) 52 02 / 92 62-0
Fax: +49 (0) 52 02 / 92 62-39
E-Mail: info@westermann24.de
Website: <http://www.westermann24.de>

Anfahrt / Directions

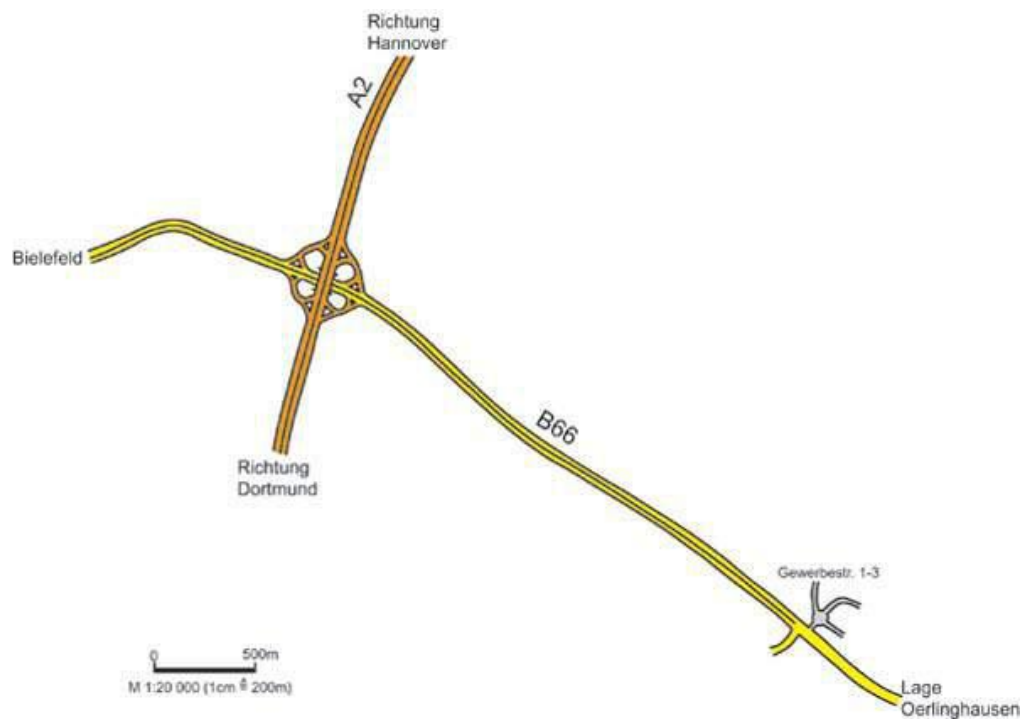



Westermann24

Gewerbestr. 1-3
33818 Leopoldshöhe-Asemissen
Germany

Tel: +49 (0) 52 02 / 92 62-0
Fax: +49 (0) 52 02 / 92 62-39
E-Mail: info@westermann24.de

